

# HDS-455 TOWER SPEAKERS

## FLAG SHIP

The HDS455 is a floor standing speaker that is the Flag-Ship of our DST-HDS range of speaker systems. This unique design incorporates the latest in design technologies and philosophies to produce a speaker of remarkable accuracy and transparent audio / video reproduction never achieved before at this pricing level.



## PEERLESS BEST 6.5" DRIVERS

Utilizing the best from the Peerless range of HDS (High Definition Sound) drivers, the HDS455 uses two 6.5" Phase-Plug, cast alloy drivers made from five layer paper-poly laminated sandwich cone, double anchored to an open ventilated 30mm voice coil system with aluminium phase plug and shorting ring. This acclaimed driver represents the culmination of over a 70 years experience of Peerless Denmark.

## CUSTOMIZED TWEETER

The HDS tweeter matches these drivers perfectly as it was specifically developed by our designer Russell Storey, for this particular application.

## ACOUSTIC ALIGNMENT

The HDS tweeter is counter sunk into the box, improving its efficiency and directivity as well as correcting its phase and time shift in relation to the mid-woofers. This ensures all sound leaves the box and reaches your ears at the same time, dramatically improving the attack and dynamics of your audio and video reproduction.

## MTM DESIGN

The coaxial placement of the drivers in a Mid-Tweeter-Mid configuration, along with the time alignment, achieves a central pin-point focus reference of the sound source to the tweeter. As a result, the music and movie sound stage is precisely located giving an extremely accurate positioning of all instruments and effects for a more open and transparent reproduction. Two drivers also offers more efficiency, maximum output and lower output frequency while maintaining a narrow cabinet design.

## HAVE A LISTEN !

Excellent quality of construction, attention to detail with design and manufacture, all aspects of this system will impress you.

To hear these speakers will enlighten you to what is now achievable with the new designs and technologies available from the best in Europe and Australia. DST Australia have now made all this available to any DIY audio enthusiast and with excellent value for money.

Australian  
Made Boxes  
With Danish  
Speakers

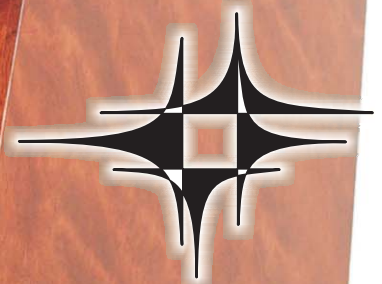

Peerless

danish sound technology



AUSTRALIAN  
DISTRIBUTOR  
sales@wes.net.au

**WES** COMPONENTS Aust  
Asia  
Phone (02)9797-9866 Fax1 (02)9716-6015 Fax2 (02)9799-7051





THE HDS/XLS FAMILY



EXCELLENT HOME THEATER

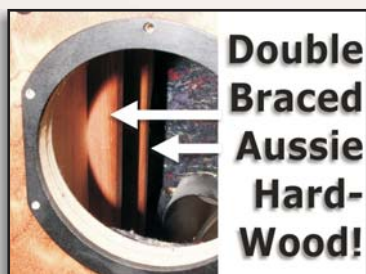

CRAFTSMAN BUILD QUALITY

# HDS-455 TOWER SPEAKERS

# Peerless

danish sound technology



## HDS Home Theater

### Available in Kit form

### Only premium quality components are used

### Professionally Optimized Audiophile Product

### Save Money By DIY



HDS455

## PEERLESS HDS/XLS SERIES OF SPEAKER SYSTEMS

*Designed By Russell Storey of Stones Sound Studio.*

Welcome to our new range of HDS & XLS speaker systems available in kit form. Every aspect of the cabinet design has been optimized to suit the new HDS Peerless drivers specifically with port and box volume tailored to maximize the performance of the HDS and XLS range of premium drivers.

This is a true Audio-Phile tower speaker using beautiful Australian cabinet materials, exotic electronic components, top-line Danish drivers, genuine audio philosophies and authenticated design technologies to produce a properly mastered, premium product to rival most high end audio. These tall, handsome floor-standing speakers were designed with immaculate music reproduction in mind. A superb musical speaker will also be very suitable for the home theater system. We highly recommend the matching of these premium speakers as mains with our HDS250c center speaker and either the HDS250 or HDS150 speakers as rear surround drivers for an exceptional home cinema setup.

A new improved tweeter has been developed in conjunction Peerless Denmark and Russell Storey, our audio consultant, to closely match the HDS series of mid-woofers. Cabinet development has been achieved using the latest in computer analysis software including LEAP and LMS along with the design experience of Stones Sound Studio who specialize in premium, exotic, custom speaker design. All cabinets are precision made from medium-density custom wood (MDF) with a choice of veneers and the best in computer controlled cabinet manufacturing processes. The Peerless HDS range of drivers and matching XLS range of subwoofers, offer incredible performance and value for money. When correctly developed with our custom designed cabinets, precision crossover matching and premium quality components, the result is a finished speaker that rivals the best musical audio available in the world, and also giving fantastic dynamics and realism to the new digital DVD home theater of today.

Thank you and enjoy.

**AUSTRALIAN DISTRIBUTOR**

sales@wes.net.au

**WES COMPONENTS** Aust Asia

Phone (02)9797-9866 Fax1 (02)9716-6015 Fax2 (02)9799-7051

# HDS455

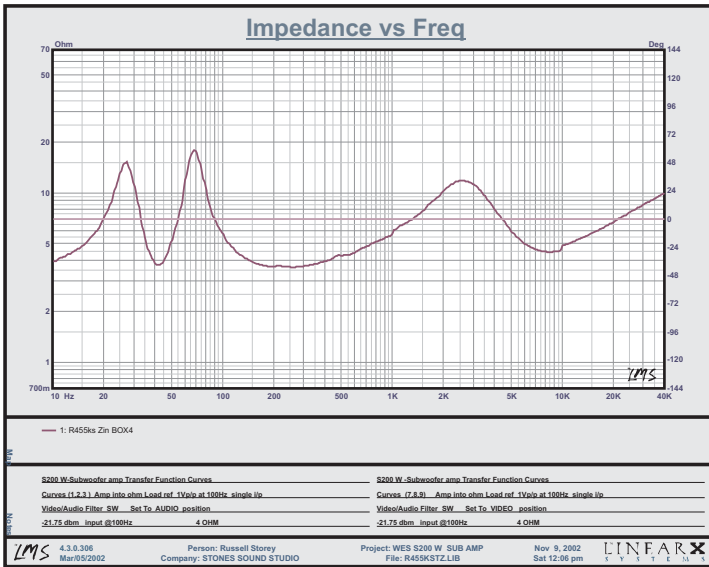
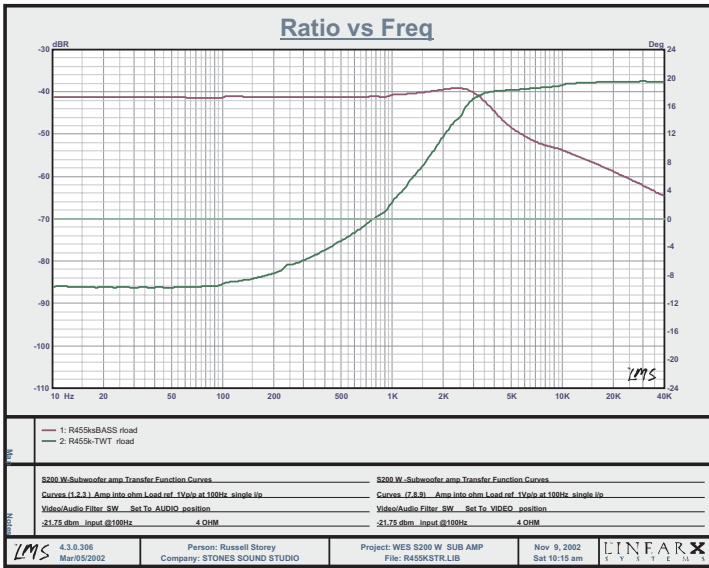



# Premium Audiophile Tower Monitors

## Phase Plug Drivers - Acoustically Aligned Tweeter

### DESIGN NOTES

Designed By Russell Storey of Stones Sound Studio

Welcome to our new series of audiophile home theatre speakers.

HDS & XLS are special high-end, high definition speaker systems for both the home theatre and music reproduction. Usually you have a speaker system where you are relaxing to your music collection in HiFi stereo. But this has now changed, with the introduction of DVD, multi-channel surround sound is here to stay! Extra demands are put on speakers as they now have to be optimised for both precision music listening as well as the dynamics of DVD home theatre action with its special effects and sound tracks. As often requested, WES Components has introduced a premium level solution. Incorporating our new and impressive Peerless range of drivers, and thanks to the design experience of Stones Sound Studio, we have a very impressive and capable range of speakers, all at a reasonable WES Components price.

### Premium Cabinet Design and Manufacture

The latest in speaker analysis and design software is used to accurately establish correct box tuning to suit specific driver specification (also measured by SSS). Various prototypes were then tested and improved upon until the desired sound was achieved. Months of work and many years of experience combine to produce a well balanced sounding speaker system. Premium audio quality demands only the best and we also understand that your room and life style today wants minimal visual impact. So we have developed cabinets that are both attractive and functional yet optimised for the best possible performance, considering cost. The attention to detail, build quality and professional finish of these cabinets is very impressive. Available in an economical black vinyl option or very handsome, genuine wood veneers.

### Peerless of Denmark

Peerless has been making drivers in Denmark for leading speaker manufacturers, providing cutting edge premium quality units, since the 1930's. This new series of speaker units is a culmination of their many years of experience and the best driver materials & accurate manufacturing techniques. Below are some examples of the modern technology incorporated.

### NEW Peerless HDS tweeter

Our new HDS Peerless tweeter is a 1" treated cloth soft dome unit, developed by Stones Sound Studio in conjunction with Peerless of Denmark. This brand new tweeter was specifically redesigned and adapted to our new HDS series of speaker boxes, and features a wider, smoother sound dispersion with the alloy flat face plate, giving better, flat, off-axis response, excellent dynamic range and an improved natural sound. Micro low level detail is achieved with a pure copper voice coil, a low inductance motor system, conical felt damped internal cavity chamber and the use of high density reversed Double-Magnets which produces maximum flux density yet lowers the stray magnet field for shielding. The voice coil now uses a new, extremely low viscosity ferro-fluid which aids in keeping the tweeters heat dissipation temperature down, reducing compression and increasing the dynamic program range and maximum power of the unit. The efficiency and detail of this newly developed tweeter outperforms units many times its cost and being specifically matched to our new speakers gives us an amazingly high performance audiophile sound at incredible value.

### HDS Peerless High Definition Series of Mid-Woofers

The design achievement of this new driver series is an impressively ample and articulate sound from compact units. Advanced build technology with an aerodynamic, ridged cast aluminium frame holding an oversized, high flux magnet, a low compression, rear ventilated, Nomex spider, SBR rubber surround and a 5 layer polymer laminate cone, double bound to a high power, quad wound, voice coil that has over an inch of travel in an improved, distortion reducing magnet system using aluminium shorting rings (and a phase plug for the HDS455s). Dramatic improvements in dynamics, efficiency, detail, maximum dB output, and long term reliability from such compact drivers, that sound and also look like they are very high performance.

### Premium Component Crossovers

Components used in the HDS & XLS range are all premium quality for best audio performance. A new range of inductor coils and capacitors was imported by WES Components to achieve the best sonic performance at a reasonable price. The Solen range of capacitors, for example, was developed in France for the European Space Agency! Only air coils are used, because of their sonic performance. Gold connectors and OFC cabling, all combine to maintain a very high level of sonic purity.

Sound Signature Matched For Home Theatre

To best reproduce the DVD home theatre audio experience, it is recommended by most installers that all speakers be identical. This is to achieve a seamless transition of sound from one speaker to the other without any obvious change in tone. You can accomplish this by using a combination of all HDS250 speakers (HDS255c as centers). However, it can also be achieved by the use a combination of different speakers in this range, due to the close sonic resemblances of each HDS speaker. eg. For a most impressive setup, use the HDS455 as mains, the HDS255c as your center and the conveniently compact HDS150 or HDS250 as surround speakers. The choice of XLS800 or XLS1000 depends on room size and potential listening volume.

### Curved Edge Design

Where possible or practical, edges in the box are tapered. This includes the speaker grills, internal bracing and the port edges. When a sound wave from a loudspeaker reaches an edge of a speaker cabinet, for example, it creates a new source of sound that appears to emanate from there, referred to as "Edge Diffraction". Rounding off corners will reduce this diffraction distortion. It is also a prime example of the attention to detail the designer has gone to achieve the best results possible.

### Acoustically Aligned Coaxial Array

If you look at the HDS250 and HDS455, you will observe the tweeter is COUNTERSUNK into the box with a mid-woofer above and below. As a result of this alignment, the sound from the tweeter leaves the box and reaches your ears at the same time as the mid-woofers sounds. This eliminates the usual midrange delay, reducing "Lobbing" (sound interaction between drivers) and achieving a near perfect transient response. This physical alignment, the unique front face tweeter flaring and the precision crossover phase alignment, all work together to give many transient improvements, particularly at the obstreperous crossover frequency point. The focus and realism of each performance will surpass what standard flat baffle speakers can normally reproduce, and all with consummate accuracy. Horizontal and vertical off-axis response is also improved, producing a greater "sweet-spot" and giving a wider, deeper 3D sound stage perception, reducing the fallacious effect of where you are in the theatre. Everywhere is the best seat in the house!

### Bi-Wire & Bi-Amp Compatible

Dual binding posts on all HDS models for the option of connecting signals to the tweeter and mid-woofers separately. This allows use of multiple amplifiers with active crossovers or, a more controversial tweak, you can bi-wire from a single amp. It is claimed that this will improve tweeter response and efficiency. The gold binding posts are shorted as default for normal twin cables. We do highly recommend though, the use of transcendent quality OFC cables for connection as direct improvements will result. SSS recommends our WES Code OFC348 cable as the best value for money. We use this cable for internal wiring on all HDS models.

*Thank you and Enjoy!*

Considerable time and effort has been put into the development of this series of speakers by Stones Sound Studio and WES Components. Given the opportunity of available high-grade components from WES and the experience and resources of SSS, we believe we have achieved a series of home theatre speakers that will rival most solutions available, anywhere! And with WES Components competitive pricing structure, this has been achieved with exceptional value for money.

Turn it up, I want to listen to the music now!

# HDS

High Definition Series

## Peerless HDS455 2-Way 3-Speaker Acoustically-Aligned Tower Speaker



### HDS455 - Instruction Sheet

#### Contents of KIT455 (Complete Kit):

HDS455-xx	Cabinet (xx=Colour Code)
	With Black Speaker Grill
XOK455	Crossover Kit 2-Way
Woofers 6.5"	2x 850467 Peerless Phase Plug
Tweeter 1"	810653 SSS Peerless
Screws x20	STS7B (7mmx20mm)
Gasket Tape	Approx' 2 metre
Felt cotton waste	(Supplied with box)

#### Tools You Require:

Screwdriver Philips 1 point.  
Battery drill with Torque setting  
Drill bits (2mm for pilot holes)  
Centre punch and/or pen  
Hammer and Ruler

*Designed By Russell Storey*

#### Optional Extras for each speaker:

20Kg of washed beach sand for each speaker base.  
Four adjustable spiked feet for each speaker base.

#### Before You Start:

Check that all contents of the kit are supplied and in good condition.  
Make sure you have a clean work area. It is recommended you use a drop sheet so that your work does not scratch the cabinet.

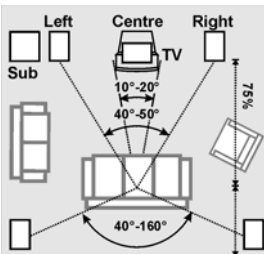

#### HDS455 Positioning and usage:

The HDS455 is a premium speaker system that has been developed for high performance home theatre impact and yet also faithfully and precisely reproduce all kinds of music, regardless of type or composition. A versatile speaker that offers excellent performance on a wide range of signals and sources, in an attractive furniture piece. The highly efficient dual 6.5" phase-plug HDS drivers will fill a large sized room with ample volume using almost any power amplifier, from 10 to 200 Watts. For best positioning results, a speaker likes centre stage. For optimum music listening it is desirable to have the speakers approximately 2.5M to 3M apart, and around 3M away from the centre listening position, toed-in by 10° if desired.

However, this obviously changes depending on the room shape & acoustics and aesthetic or domestic compromises. Please experiment, as a slight position change can drastically improve or ruin the acoustic situation. Be careful not to obstruct the rear port, about 10/15cm clearance minimum is good. The Phase-Plug drivers are NOT shielded, so placement in a theatre system near the TV might require some assiduity. When moving the HDS455s' around, switch off the TV, this will minimise gauzing of the screen, and don't panic, some TVs take a day or two to reset their gauze.



HDS255c Center Surround

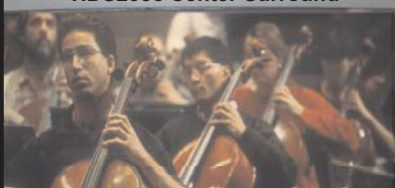

We highly recommend that to complete your audio-visual experience, you match your new HDS455 with other speakers from our HDS range, including centre, surround and sub-woofer. Using matched speaker systems in home theatre greatly improves acoustic perceptions as all the signal sources are similar, giving you maximum audio impact with seamless integration. Systems shown without grills.



HDS150 (Excellent for surround Sound!)

SPEAKER GRILLS ARE SUPPLIED

## XON - CROSSOVER FAQ

### WHY A DUAL PAIR TERMINAL CUP ?

Our premium grade HDS Series of speaker systems come with dual pair terminal cups. This facilitates connection to both the upper and lower frequency drivers separately. Generally this is not required for a normal audio system set up but is given as an option for Audiophiles who wish to take advantage of the improvements from Bi-Wiring or Bi-Amping.



### BI-WIRE CONNECTION

This refers to the running of separate cables from the amplifier to both the high range and low range drivers. This arguably improves definition and focus by improving the amplifiers damping and reducing intermodulation crosstalk between the woofer and the tweeter.

*"An inexpensive tweak for getting the best sound quality from your investment".*

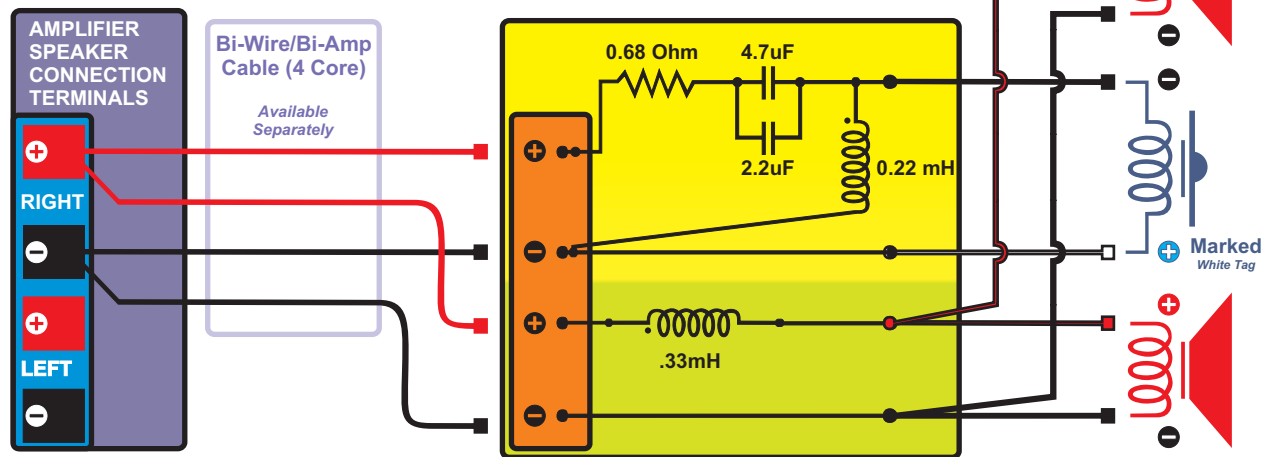

### NORMAL SINGLE WIRE CONNECTION

**A)** If you do not wish to use Bi-Wire or Bi-Amping, then simply leave the supplied "Shorting-Straps" in place on the rear terminal block and use a standard speaker wire pair to connect your speakers to your amplifier system. Please note that the Gold plated terminals must be tightened securely so the straps don't accidentally slip loose over time with the speakers vibration and one driver stops functioning due to being disconnected.

**B)** As an option to stop this from happening, you could solder in the shorting links on the Crossover Circuit Board (Shown as "Links 1" & 2).

**C)** Alternatively you could connect the input speaker cable from your system to both terminals.

**DOUBLE CHECK ALL WIRING AND PAY PARTICULAR ATTENTION TO POLARITIES AS**

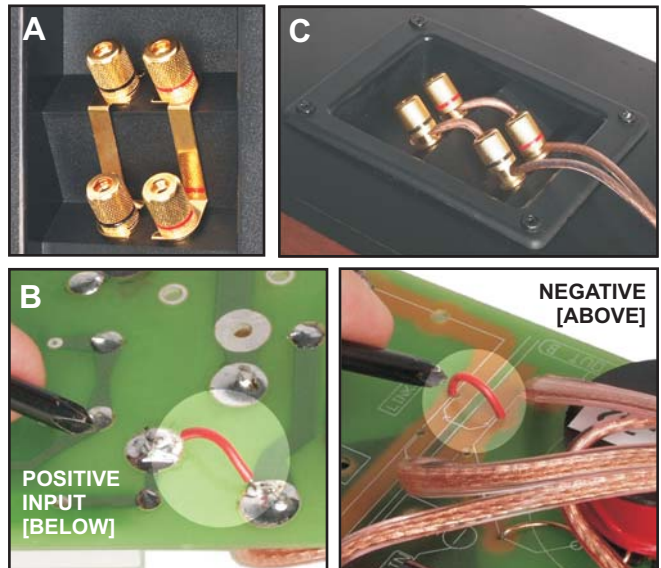

### XON455 TO SUIT SPEAKER KIT HDS455

Bessel - Butterworth 2 Way Crossover  
Acoustically time aligned with cabinet  
Matched to Peerless drivers;

Tweeter	810653
Woofers (X2)	850467
Crossover Frequency	2319Hz
Low Pass Filter	6dB/Octave
High Pass Filter	12dB/Octave

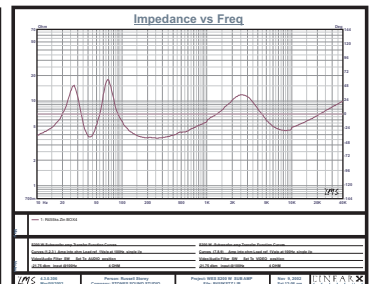
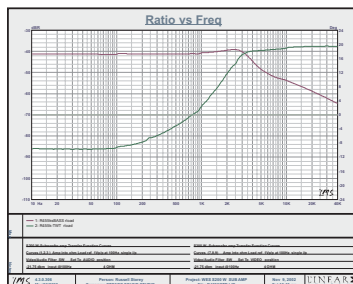



## INSTALLATION INSTRUCTIONS - HDS455

Locate all parts and check condition of each item.  
 Familiarise yourself with the instructions and parts.  
 Review how it all fits together before commencing.  
 Double check your work before final assembly.  
 Check all connection polarities (*Most common error*).  
 Insert Crossover 1st, hang the leads out each hole.  
 Attach connectors and screw in the rear terminal cup.  
 Position the cables away from the Woofer and port.  
 Attach connectors and screw in each of the drivers.  
 Attach speaker cables to amplifier and enjoy!



Please double check your work for best results will achieve best sound.

### CROSSOVER CONNECTION:

Ensure all connections are tight and secure with all polarities correct.

If you have a Soldering Iron, a drop of solder makes for excellent reliability.  
 Velcro strips are supplied as a quick and easy solution for affixing the Crossover Circuit Board directly to the inside bottom of the speaker box. Attach the Velcro strips to the underside of the Crossover Circuit Board. We suggest positioning flat onto PCB where there is no solder blobs to distort the tape and its adhesive surface. Use all six for a most secure fit. Ensure Bottom Inside of the Box is clean of dust, etc. (with a damp cloth). Familiarise yourself with the boards connections and where they should go. Identify the leads to be connected to the rear plate from the diagram below. Remove Velcro tape to expose the sticky and Insert the Board into the speaker through the woofers hole and stick down on the bottom side. Now attach the four appropriate leads to the rear terminal plate.  
 Insert the rear terminal plate into the cabinet with the supplied screws. Take care not to over tighten and crack the plastic.  
 Next stage is to install the drivers.....

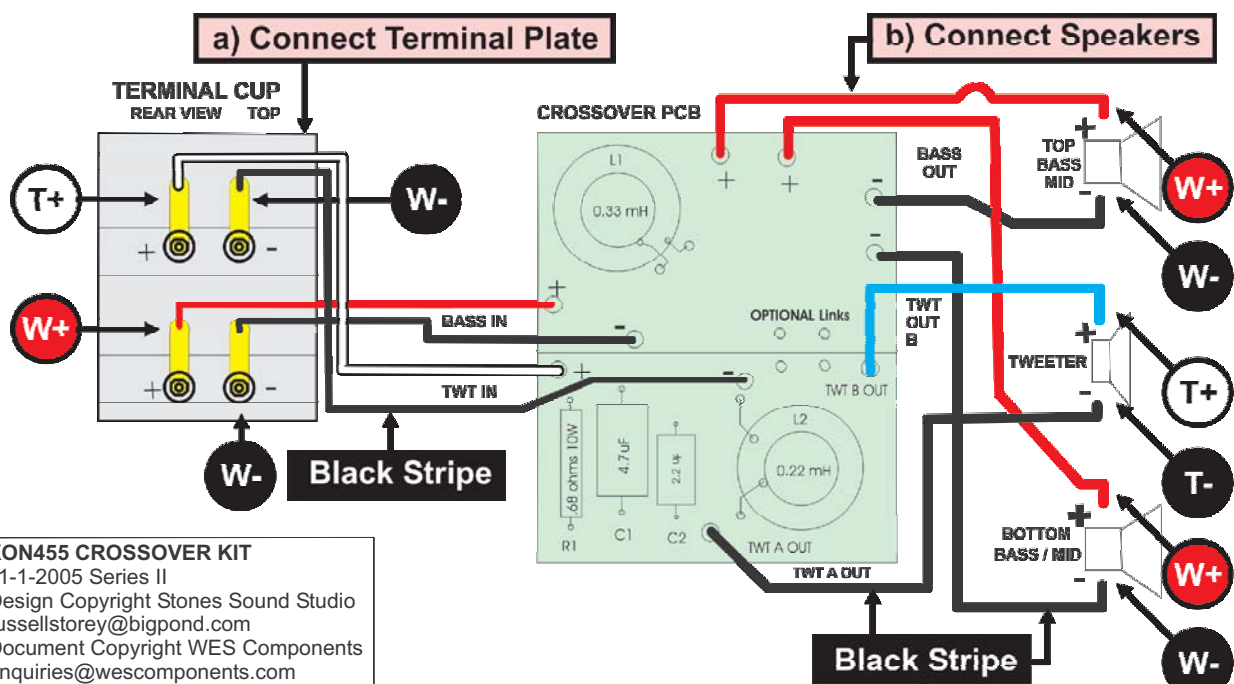

**XON455 CROSSOVER KIT**  
 11-1-2005 Series II  
 Design Copyright Stones Sound Studio  
 russellstorey@bigpond.com  
 Document Copyright WES Components  
 enquiries@wescomponents.com

# HDS455 - Speaker Box Instruction Sheet



Place your speaker cabinet on a non-slip, non-scratch surface.

**Insert the Speaker Terminal Cup** into the rear panel. Internal speaker cables thread thru the Internal Damping Cloth. Check the cables have sufficient length to reach each speaker and don't catch anywhere or obstruct the port, etc. Aim the 4mm Banana plugs UP (*This stops the plugs falling out!*). Screw in using four of the supplied black screws, not too tight or you may damage the plastic panel.

Illustration shows Bi-Wire/Bi-Amp cable connection example.



**Apply the gasket tape.** This is essential for an air-tight seal. Use the speaker drivers packaging to hold and protect the face and dome/surround when applying the gasket tape.. For the tweeter, carefully run the tape around the outer circumference once then cut off excess. For the woofer, keep to the inner rim of the drivers mounting flange, again, only once around then cut.



**Drilling pilot holes for the woofer:** Align the drivers flat edge to the vertical edge of the cabinet making sure it is absolutely square. Hammer in centre punch for the six screw holes. Remove the driver and drill a 2mm pilot hole for each.

If the felt is supplied separately, insert it now. For best results, we recommend only a modest amount, single ply, on the rear panel. Also, cup a 6" square piece over the back of the tweeter. Ensure the felt is secured and will not touch any moving part of the woofers or obstruct the port tube.

Affix felt and anchor cables using a heat glue gun or a small staple gun. Check the speaker cables for ample reach and that they too will not touch the woofer nor obstruct the port or rattle against the cabinet walls, etc.



**Attach the drivers.** Apply the spade connectors to their respective drivers, ensuring you have the correct polarity. We recommend you also solder these connections for excellent long-term reliability.

**BEWARE** not to apply too much heat to the tweeter contacts or damage to the plastic mounts can occur. Only a small amount of solder is required for a secure connection.

**Screw in the drivers,** carefully, moving to opposing screws and tightening until the driver is flush with the cabinet and not too tight as to thread the screw. If using an electronic screwdriver, set it to a medium torque setting, and use your hand for the final tightening.

Illustration shows the single layer felt applied to the back panel. Also a piece set to cup the back of the tweeter.

Notice too, the **VERTICAL ALIGNMENT** of the drivers edge to the cabinets edge.

This alignment is required for the grill to fit correctly.

## Attaching the base plinth:

Although the 11" wide base plinth is sufficiently stable for a speaker of this narrow height, it is also recommended that you fill each bottom cavity with 20Kg of "Washed Beach Sand" (*Not Supplied*). This will form additional dampening to the box, improving sonics and reducing distortion while also making the tower speakers bottom heavy and thus more stable. Internal bag is supplied. Spike feet are also optional, add 3 non-adjustable or 4 adjustable.

Sand Cavity



Fill 20L



Tie the bag up to seal



Screw on Plinth



Screw or Glue on Spiked Feet (3x or 4x)





**AUDIOPHILE TOWER SPEAKER MONITORS 2-WAY 3-SPEAKER  
HDS455**

OUTSIDE DIMENSIONS

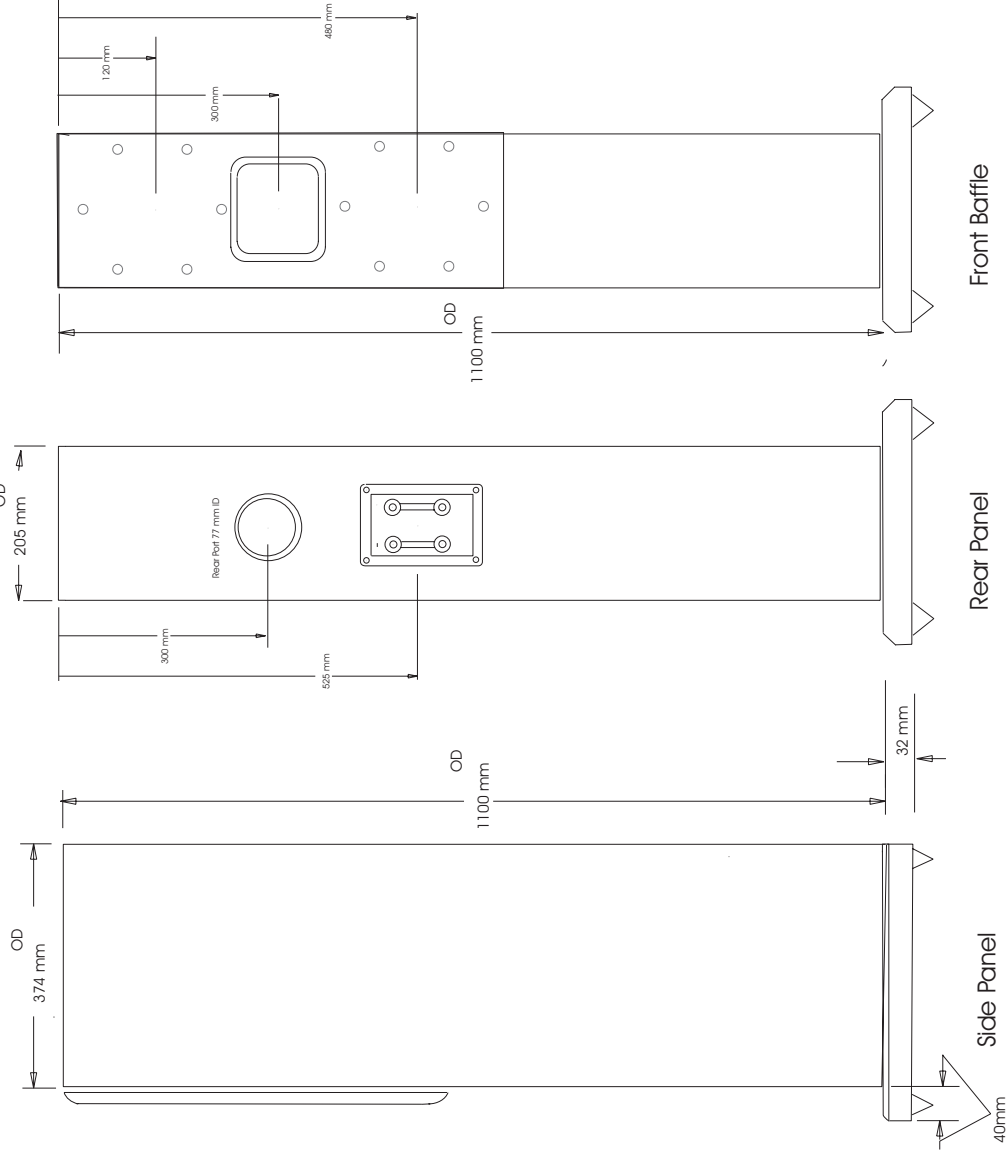

- NOTES**  
 Base plinth 32mm MDF (Black satin lacquer)  
 Base plinth 45 deg beveled edge on 3 sides 16mm wide  
 19mm MDF Veneered  
 Vents rounded 5mm on both inside edges  
 Tweeter Flare same as R250 but with 105mm rebated tweeter

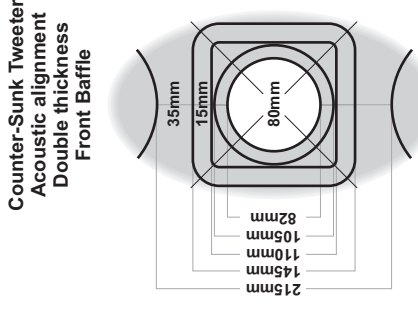

Optimised for Peerless HDS 6.5" Mid-Woofer 850467  
 Tweeter 1" Dome 810653  
 Port Size 75mmØ x 132mm

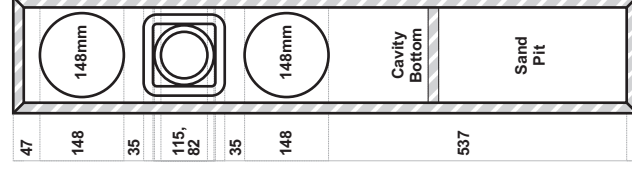

**CABINET FEATURES AND DETAILS:**  
 All internal edges are beveled, and all grill frame edges also, for lower

Upper Internal Cavity Volume for bass drivers: 320 x 720 x 170mm 40 Litres Approx.  
 Lower Cavity (Empty) for Sand filling. This deadens the box and gives a lower center of gravity and reduced resonances, improving performance and acoustics dramatically.  
 1.25" Australian Hard Wood Bracing for reducing side panel resonance. Inner edge of bracing is bevelled for reduced internal edge detraction giving lower distortion.

REV.	DESCRIPTION	DATE	APPROVED

ITEM/PART NUMBER NO. R455K5	General Dimensions Diagram	MATERIAL SPECIES:	CITY:
2x Peerless 6.5" Phase-Plug Cast Alloy 8 Layer Sandwich Cone Bass-Mid Drivers 850467	WES Components Dual Terminal Cup Code J708 Bi-Wire/8-App Type		
1x Peerless 1" Fabric Dome Ferro Fluid Coated Bucking Magnet Tweeter 810653	CAD DRAWING		
UNLESS OTHERWISE SPECIFIED DIMENSIONS ARE IN MILLIMETRES			
TOLERANCES ARE +/- .5mm			
DO NOT MANUALLY UPDATE:			
APPROVALS	DATE		
DRAWN Russell Storey	15/07/2008		
CHECKED Jim Ryan	10/09/2008		
MATERIAL High Density Particle Board			
FINISH Unfinished/Primed			
USED ON Vinyl or Wood Veneer			
APPLICATION Audiophile Tower Monitors			
SIZE DWG NO. A3		SCALE XXX:1	CAD FILE HDS455_INS.dwg
REV. R.95596 001			

**STONES SOUND STUDIO**  
**AUDIOPHILE KIT SPEAKER**  
**CAB455**

# Stones Sound Studio

# HDS455 WOOD CUT-OUT PLANS

**HDS455** - Twin 6.5" 2way speaker box with countersunk MTM tweeter arrangement. Optimised to suit Peerless HDS drivers. Wood thickness = 18mm\* Medium Density.

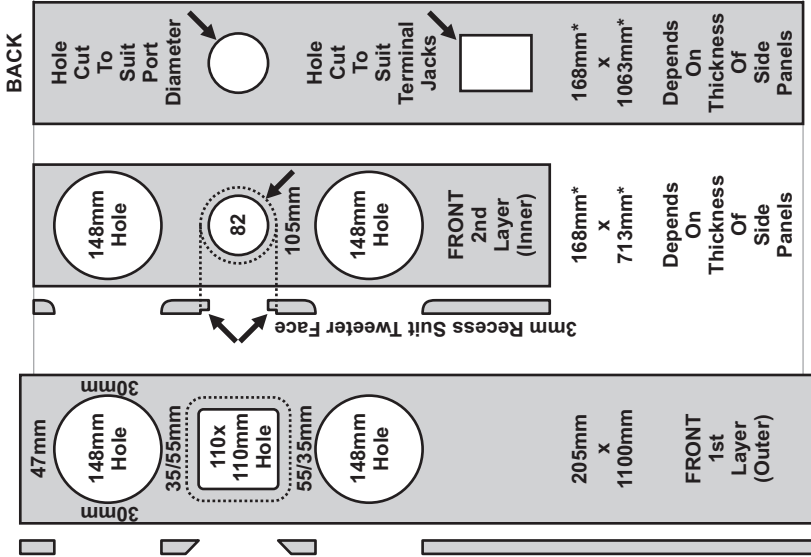

Front Panel is double thick. The 2nd panel is optional. You can replace the 110mm square hole with a 80mm round hole for mounting the tweeter direct to the front

Adding Hardwood Bracing Ribs is recommended. Any size you like, however 1 1/2" is recommended. Attach to the Left and Right sides of the box.

**Middle Partition:**  
300mm\* x 138mm\*  
Depends On Thickness Of Side & Back Panels

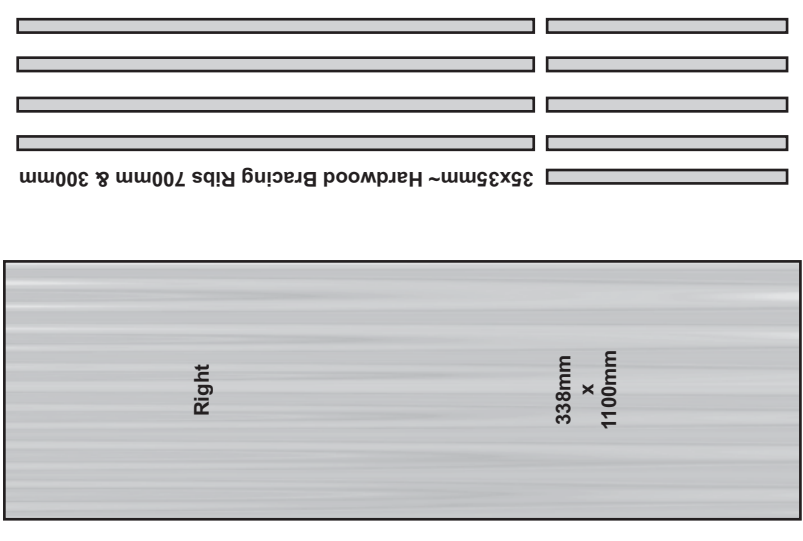
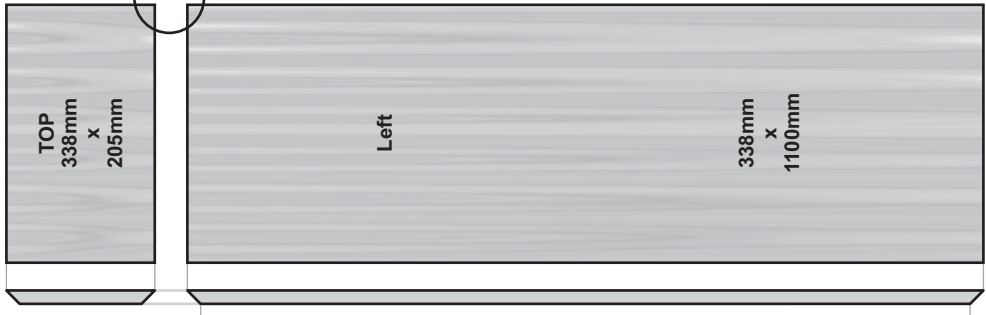

**SPEAKER GRILL DETAILS:**  
The original design, as supplied with the kit, is a one piece MDF carved with beveled outer edges. This gives the best performance. For the home constructor, a simple frame may be more practical. **BEWARE!**

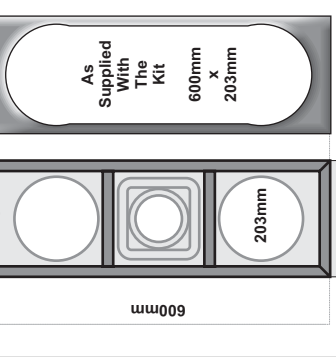

The lower Base Plinth Adds extra Stability to a tall tower design. For a lower center of

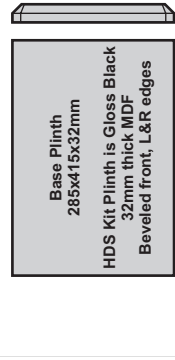

ITEM / PART NUMBER NO. R4554S	General Dimensions Diagram	MATERIAL SPECS:	QTY:
2x Peerless 6.5" Phase-Plug Cast Alloy 8 Layer Sandwich Cone Bass-Mid Drivers 850467 1x Peerless 1" Fabric Dome Ferro Fluid Coiled Bucking Magnet Tweeter 810553	WES Components Dual Terminal Cup Code J708 - Bi-Wire/4-Wire Type		
UNLESS OTHERWISE SPECIFIED DIMENSIONS ARE IN MILLIMETRES TOLERANCES ARE +/- .5mm	CAD DRAWING DO NOT MANUALLY UPDATE.		
	APPROVALS	DATE	
	DRAWN Russell Storey	15/07/2008	
	CHECKED Jim Ryan	10/09/2008	
MATERIAL High Density Particle Board			
FINISH Vinyl or Wood Veneer			
NEXT ASSY.	USED ON		
APPLICATION Audiophile Music Systems			
		SIZE DWG NO. A3	REV. R.35596.001
		SCALE: XXX:1 CAD FILE: HDS455_INS.dwg	SHEET 2 of 2

## PLUS BASE PLINTH AND SPEAKER GRILL

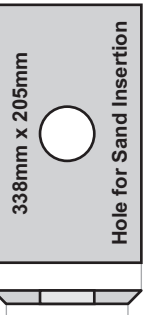

If you fill the bottom cavity with sand, place it in a plastic bag so the sand moisture wont harm the