

XLS1000 DUAL 12" SUBWOOFER

danish sound technology

Super low, super loud and super clean bass. This ultra-high performance, audio phyle sub-woofer gives out copious amounts of very tight, very fast and very accurate bass. Designed for both distortion-free music and earth shaking home theater special effects, the XLS1000 can faithfully reproduce any bass signal from the highly demanding DVD and Super-Audio CD sources. The XLS1000 will fill larger sized rooms with beautifully accurate bass of clarity and definition only achievable in an exceptionally well designed unit. The new dual 12" XLS radiator design will effortlessly reproduce the most demanding bass without distortion or "boomyness" up to incredible sound levels. Passive radiator technology has been used in our design to eliminate port air velocity noise, increase efficiency and achieve incredibly low bass in a relatively compact unit of only 60L. A truly top-of-the-line, high performance sub-woofer that will match to any high-end speaker and theater system.

**Available with Built-In Amplifier
Or without - For an external Amp.**

12" Peerless XLS 300Wrms Active Driver

12" Peerless XLS Passive Radiator

No Port Velocity Noises at high volumes

Use our 200W amp or connect your own

Attractive "Piano" Black Polished Finish

Genuine Aussie wood feature panel

Seven "Aussie Hard Wood" Bracing

Interlocking cabinet joints

Super low frequency response

Super high output levels

Super low distortion

Extrem performance and

Maximum efficiency design



**Australian
Made Boxes
With Danish
Speakers**



**AUSTRALIAN
DISTRIBUTOR**
sales@wes.net.au

WES COMPONENTS Aust Asia

Phone (02)9797-9866

**NOV.
2002**

XLS1000 DUAL 12" SUBWOOFER



danish sound technology

12" Peerless XLS 300Wrms Active Driver
 12" Peerless XLS Passive Radiator
 No Port Velocity Noises at high volumes
 Use our 200W amp or connect your own
 Attractive "Piano" Black Polished Finish
 Genuine Aussie wood feature panel
 Seven "Aussie Hard Wood" Bracing
 Interlocking cabinet joints
 Super low frequency response
 Super high output levels
 Super low distortion
 Extrem performance and
 Maximum efficiency design



Peerless XLS High Power Sub-Woofers



Passive Radiator

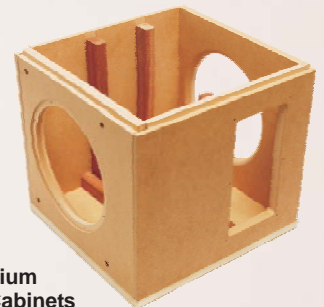

Premium Quality Cabinets



Peerless XLS / HDS Speaker System Series

PEERLESS HDS/XLS SERIES OF SPEAKER SYSTEMS

Designed By Russell Storey of Stones Sound Studio.

Welcome to our new range of high performance speaker systems available ready-made or in kit form. Every aspect of the cabinet design has been tailored to maximize the performance of the XLS range of premium drivers. These impressive drivers use cast iron baskets with double magnets and a highly efficient and robust motor system. *Extremely Long Stroke* roll surround and open spider for low compression and low distortion at very high sound levels not previously achieved in such small box volumes. A 12" Passive radiator is used in the rear of the box to tune the subwoofer performance and add extra bass output at frequencies below what is normally achievable by conventional drivers. This design achieves ultra-low distortion at even very high volume levels and a frequency response that extends below human hearing, it will make the couch shake! Double thick 25mm cabinet walls and 36mm front baffle with unique box construction techniques, double panel bracing, interlocking carpentry joints, curved outside edges and all internal edges are also curved to reduce any turbulence noises generated by the intensely high air velocities involved. A new 200Wrms, protected subwoofer amp has been developed in conjunction with our audio consultant, Russell Storey, to achieve remarkable performance from such a reasonably priced unit. This all-enclosed all-improved amp module has a frequency response below 10Hz with very low harmonic distortion at these frequencies (beware - most amps fail in this area) and built-in overdrive protection with EQ switching and low-pass adjustments. This amplifier will fulfill the needs of the most discerning users, however, the performance potential of the XLS subwoofer is such that any additional expenditure on the amplifier stage would improve over-all performance and sound quality. To this end we have also made available an XLS1000 kit without an amp hole cut-out so that you may add your own internal or external amplifier solution and really disturb your neighbors. The XLS1000 will reproduce the lowest tone of a pipe organ, rattle your windows with the "12th overture", make puddle rings in your drinks on the coffee table with Jurassic Park and bring the police around while watching the latest James Bond movie. Beware and enjoy.

AVAILABLE IN TWO MODELS

XLS1000:
 WITHOUT AMP - EXTERNALLY
 AMPLIFIED

XLS1002:
 WITH 200Wrms AMPLIFIER BUILT-IN

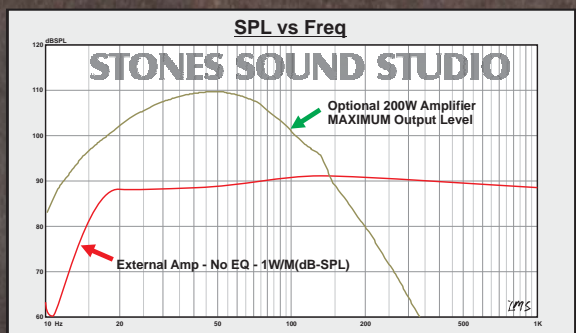

**AUSTRALIAN
 DISTRIBUTOR**

sales@wes.net.au



COMPONENTS Aust Asia

Phone (02)9797-9866



XLS

eXtra Long Stroke
Peerless Sub Woofers

Peerless XLS1000 12" SUB-WOOFER Instruction Sheet

Designed By Russell Storey

CONTENTS OF XLS1000 KIT:

CAB1000-xx Cabinet (*xx=Colour Code*)
With Black Speaker Grill
With Wood Feature Panel
Woofer 12" 830500 Peerless XLS Sub
Passive 12" 830548 Peerless XLS Sub
Screws x20 STS8B (8mmx25mm)
Gasket Tape Approx' 2 metre
Grill Clips SGC12

CONTENTS OF XLS1002 KIT:

Components as above but with AMP.
CAB1002-xx Cabinet (*xx=Colour Code*)
S200W 200Wrms Sub-Amp

OPTIONAL:

Spiked Feet SPIKE35 x4

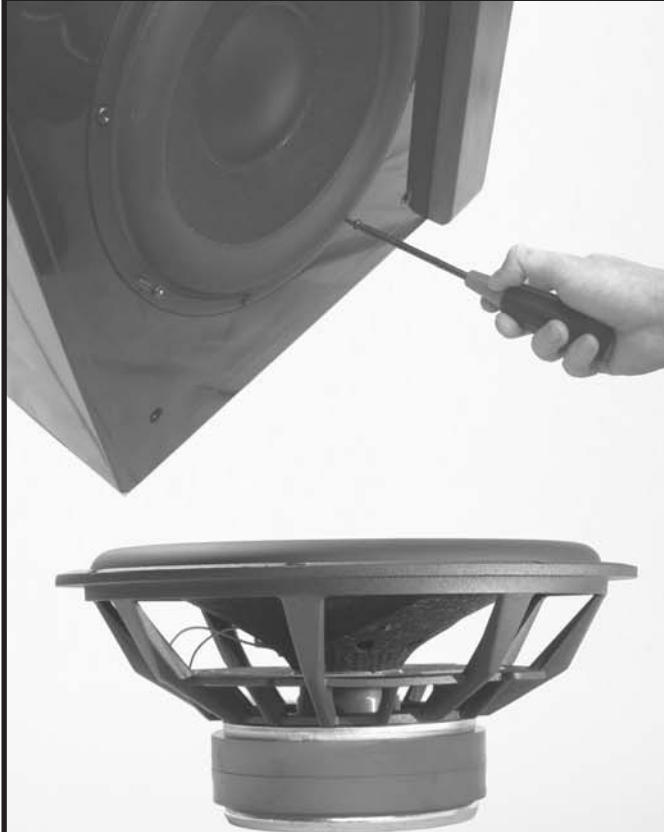

- Staple internal wadding
- Insert S200W Amplifier
- Insert Passive Radiator
- Attach Cables and
- Insert Main Driver
- Attach Spiked Feet
- Glue Feature Panel
- Test and setup



XLS1000 - Speaker Placement Suggestions

EXPERIMENT ON ROOM LOCATION FOR THE XLS SUBWOOFER BOX

The biggest impediment to good quality bass from your subwoofer usually has little to do with the subwoofer itself, but its location within the room. The problem is that a sub produces extra long wave lengths (bass) that form "Standing Waves" in the room, resulting in a potentially uneven distribution of sound level at your favourite listening position. Some attention to the location of the subwoofer can help dramatically improve your listening experience and achieve remarkable improvements in sound quality.

CORNER PLACEMENT

We recommend that you keep your XLS1000 away from the corners by at least two feet. Corner placement can increase the bass output, but this location can excite large amounts of unwanted room resonances that will rattle objects and may give a boomy note to your bass sound. Try "Setup C" as an experiment. You may and like this setup, you are the final judge. Just watch that crockery!

RECOMMENDED LOCALES

In "Setup A & B", you are placing the XLS1000 so that the distance from the subwoofer to the nearest wall and its opposing wall is different. This will stagger the standing waves so that they don't compound up on top of each other, produce rattling resonances.

Experimenting is the key, trying different locations for both you and the sub will show benefits of what's possible and thus help in resolving a final location with minimal compromises. Locating the XLS1000 toward the front, as near to your main speakers as possible is also recommended. Remember also to be careful not to obstruct the rear firing woofer, this is the subsonics.

I CANNOT HEAR THE SUB?

The XLS1000 is an exceptionally clean, distortion-free subwoofer. As a result, it can be quite difficult to judge the bass content and correct location of this sub and therefore feel immediately satisfied with your location decision. After all, subsonics are felt not heard! The subwoofer location experiment may require some living with, and along with the adjustments of level controls, etc, the final setup may take some extra time and many different media sources before you are generally satisfied that your getting maximum sound quality from your XLS1000. Although, if you cant exactly here the sub, its probably perfectly tuned and in the best location!

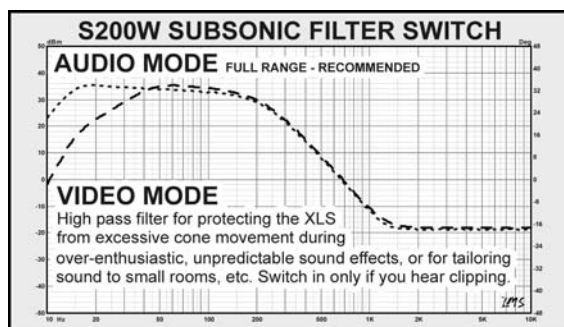
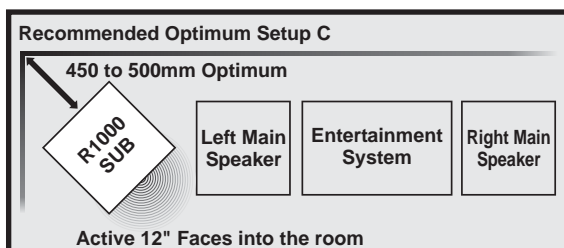
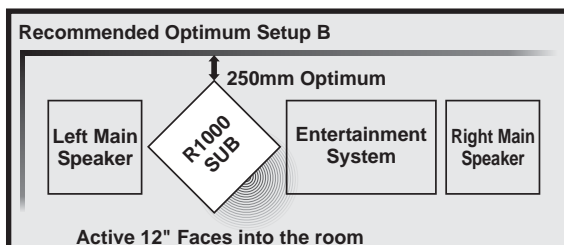
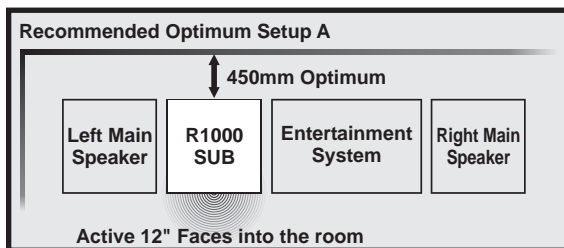

S200W AMPLIFIER CONNECTION & ADJUSTMENTS

The S200W included with the XLS1002 is a 200 Watt RMS amplifier capable of producing clean audio from 180Hz down to below 20Hz.

HOME THEATRE

For home theatre, connect the S200W via twin RCA to a single RCA adaptor into the SUBWOOFER output on your home theatre amplifier. Adjust the FREQ to maximum (180Hz) as the bass filtering is done by your home theatre amp (See its instruction manual for details).

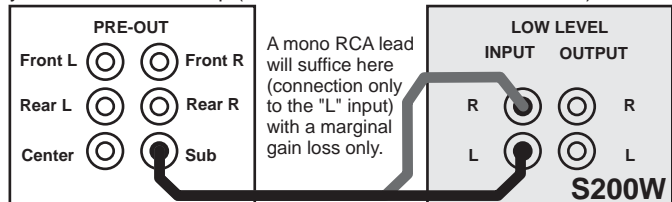

HIGH-END AUDIO AMP & PRE-AMP COMBINATION

Similar to above. Connect to the amplifiers stereo PRE-AMP outputs. Use RCA splitters as we recommend NOT connecting to the OUTPUT on the S200W as it is NOT high-pass output filtered. Once attached, adjust the S200Ws' FREQ. control to suit your main speakers. eg. Very small satellite mains would require about 100 to 150Hz. Full sized mains would require a lot lower, say 50Hz or less.

Adjust the FREQ control until you are happy with the overlap. That is that there is minimal sound being produced by both speakers which may give you a boomy sound at this crossover point. Adjust to ear.

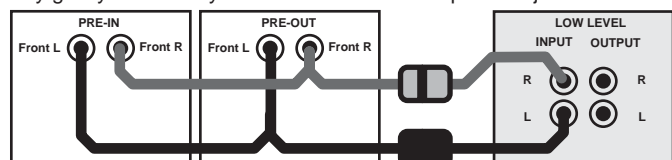

PHASE SWITCHING

Simply try it in and out of phase; whichever way has the most bass is the right way. If it's too much bass, try adjusting the FREQ. or just turn the subs gain down.

VIDEO-AUDIO MODE

"VIDEO MODE" is a subsonic filter (<20Hz) to protect your XLS1002 from excessive cone movement. If you are in a small or difficult to tune room, or if you are listening to ridiculously loud music or special effects, or if the CD or Turntable keeps skipping, or your neighbours keep complaining, you may wish to switch in the Sub-Sonic Switch to "VIDEO" mode to protect your unit from damaging sub-sonic energies.

XLS Peerless XLS1000

Instruction Sheet

eXtra Long Stroke
Peerless Sub Woofers

Contents XLS1000 & XLS1002 Kit:

CAB1000-xx Cabinet (xx=Colour Code)
With Black Speaker Grill
With Wood Feature Panel

Woofer 12" 830500 Peerless XLS Sub
Passive 12" 830548 Peerless XLS Sub
S200W 200Wrms Sub-Amp (XLS1002)

Screws x20 STS8B (8mmx25mm)

Gasket Tape Approx' 2 metre

OPTIONAL:

Spiked Feet SPIKE35 x4

ESSENTIAL FOR STABLE BASS PERFORMANCE.

CHECK THE CONTENTS!

READ THE INSTRUCTIONS!

Check that all contents of the kit are supplied and in good condition.

Make sure you have a clean work area. It is recommended you use a drop sheet so that your work does not scratch the cabinet.

XLS1000 - No Amplifier Hole. Blank.
XLS1002 - Includes S200W Amp & Hole.

Both units are identical other than the amplifier being supplied or not. Please follow instructions carefully for best results. Please take care as not to scratch the Piano finish paint. Spiked feet are recommended.

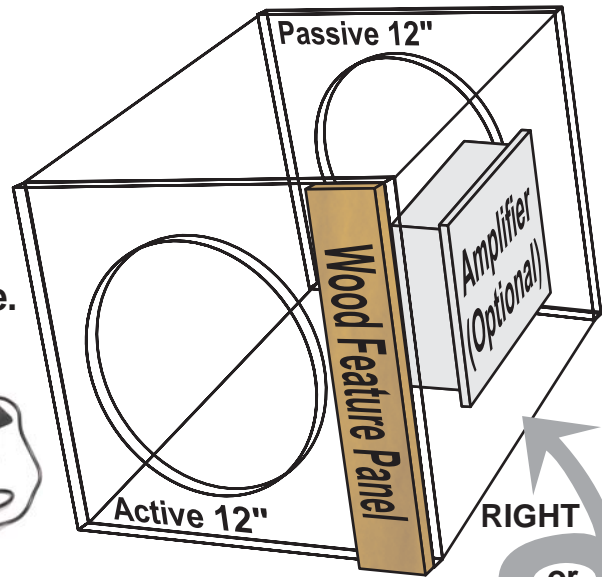

XLS1002 is shown here with its S200W amplifier and hole in cabinet to suit.

XLS1000 is without a hole for the S200W amplifier. This box requires either a hole cut into it to suit your choice of inbuilt amplifier or requires speaker cable access via a small hole or our J706 recessed single speaker socket. We would suggest you locate this on the bottom of the box for an attractive concealment.

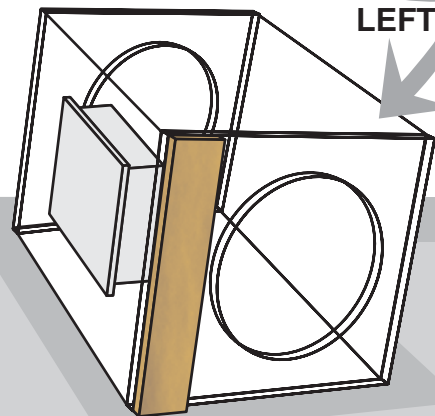

LOOK HERE! READ ME! IMPORTANT!

Once you have taken the box out of the packaging, you should make a decision on the box orientation that you desire. This is whether you want the Amplifier and/or wood feature panel to the LEFT or to the RIGHT of the front driver. Once this choice is made you will know which side is the bottom and thus where to put the feet which require holes to be drilled to affix.



For an improved, tight bass response it is highly recommended that you attach some heavy-duty spiked feet to the XLS1000. For our recommended SPIKE35, a 5mm hole is drilled on all 4 corners (in about 5 to 7cm from the edge). A nut and bolt is used to affix the feet, so it is recommended that you do the feet first, for easy bolt access and for better box stability when installing the drivers, etc.

Place your speaker cabinet on a non-slip, non-scratch surface.

Identify the orientation of the box as you desire (Left or Right).

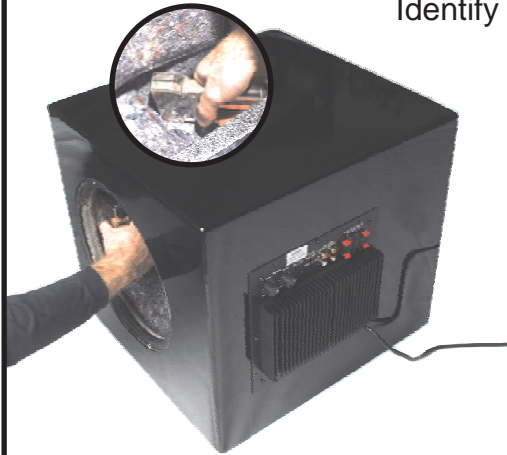

Insert the Amplifier.

The ports are on the bottom side, so make sure you install the amp upright. Pilot holes are pre-drilled so simply screw in the supplied screws, caution that you don't thread the screws by over tightening. If using an electronic screwdriver, adjust to a medium/high torque setting. Beware which way is UP!

Insert the Wadding. (Ignore as wadding is already installed.)

The internals require some dampening. Ensure you cover the amplifiers plastic cover, but allowing the connection cable thru. Split the remains into strips and place BETWEEN the bracing battens on the

top, bottom, left and right panels. Don't allow any of the wadding to touch any part of the drivers. Use a staple gun or appropriate glue. Affix the wadding to the side of the cabinet, stapling down all edges and loose areas.



Passive Radiator

Apply the gasket tape.

For a good air-tight seal between the speaker and cabinet, it is required that you apply gasket tape around the whole circumference of the flange on both of the woofers.

Insert the Passive Radiator.

This is the driver without any magnet. It is mounted on the rear of the cabinet. Identified as the hole without the feature panel or grill mounting plugs. Gradually tighten each screw, traversing across the woofer. Carefully, ensure the wadding does not interfere with the driver and that the gasket seals tight and proper and you don't thread the screws or accidentally slip and puncture the cone!



APPLYING GASKET TAPE AROUND THE DRIVERS IS VERY IMPORTANT !



SOLDERING IS RECOMMENDED



Insert the Speaker.

Cabling is supplied with the amp and will connect directly to the 12" driver. We highly recommend that you solder this connection for reliability. Make sure the cable is not going to rattle on the drivers cone. Now simply locate the driver into the flush hole and apply the screws, again tightening carefully as not to strip them or slip and puncture the cone.

Feature Panel

You may wish to leave this until after the testing stage.

Please affix the panel carefully with the appropriate GLUE (Not Supplied) and let dry as per glue instructions. The front is identified by the grill sockets.



REV.	DESCRIPTION	DATE	APPROVED

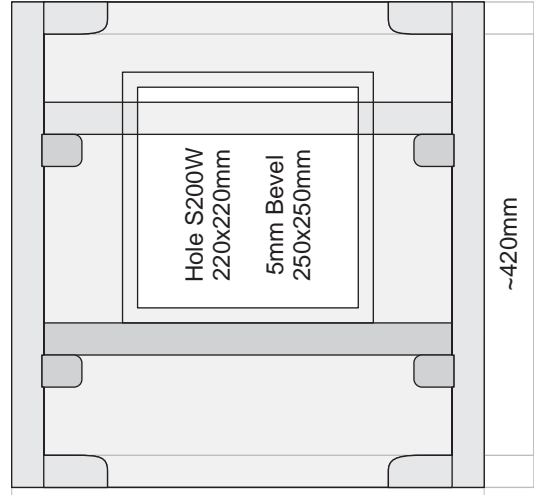
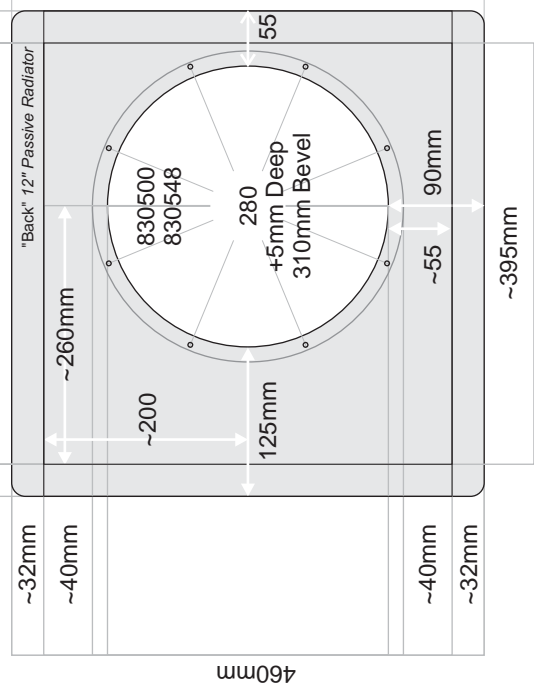
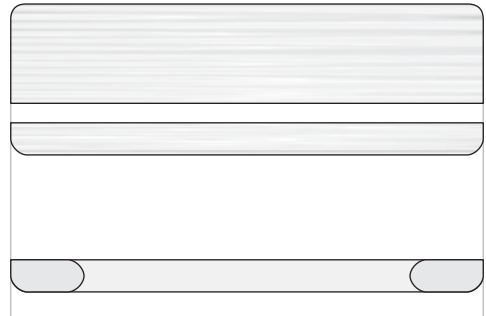
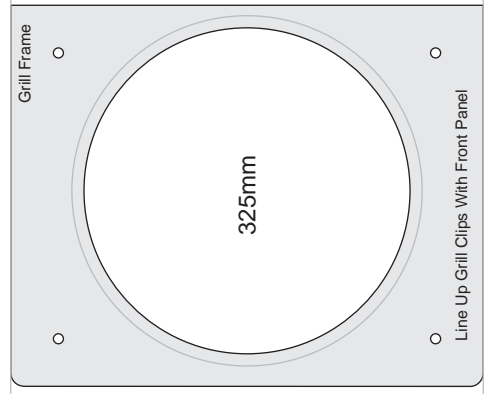
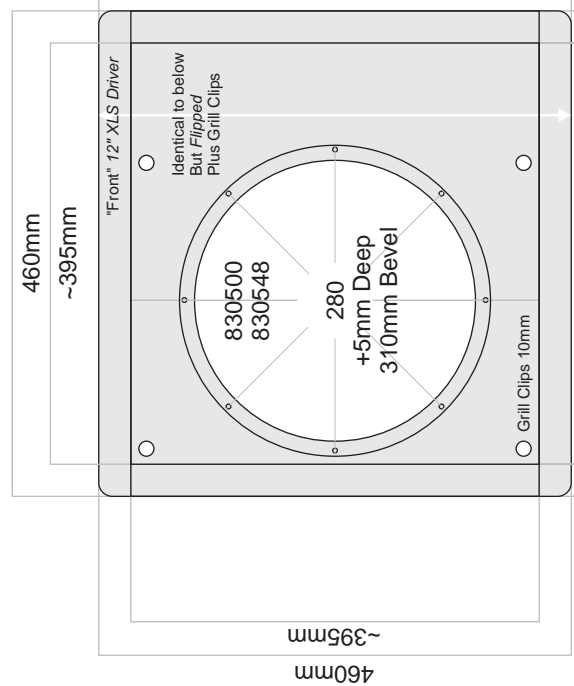

FEATURE PANEL AND FRONT GRILL
32mm thick. All outer edges beveled. Beware of dimensions as determined by cabinet wall thickness and tolerances also depend on cloth grill thickness, etc. *Feature Panel Width + Grill Width + Cloth.*

Genuine Australian Wood Feature Panel
Cabinet is universal in that the front/back can be swapped for the amplifier hole to be on the left or right.

Spiked feet should be attached, essential for stability, after final assembly.

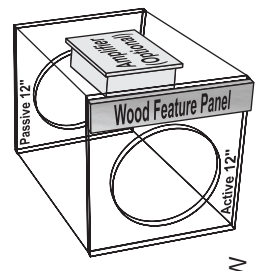

32x42mm Hardwood Bracing
Shown counter-sunk into walls (XLS1000) but not necessary. X2 each wall except AMP wall only one to allow space for S200W

ALL INNER EDGES ARE BEVELED
To reduce turbulence, less distortion.

All beveled edges are optional but recommended.

XLS1002 [With Amplifier Cut-Out]
XLS1000 [With NO Cut-Out]

TEST PART NUMBERS NO. R1000NS SSSW	General Dimensions Diagram	MATERIAL SPECS. 32mm MDF	QTY:
1x Peerless 12" Cast Alloy Composite Fibre Cone Sub Driver 830500 1x Peerless 12" Cast Alloy Composite Fibre Cone Passive Radiator 830548 *Tweaked-Up S200W Subwoofer Amplifier 200Wrms			
CAD DRAWING			
MANUALLY UPDATE TO SUIT DATE			
APPROVALS	DATE		
DESIGNER From Box, Jim Ryan	10/09/2000		
CHECKED			
VOLUME Supplied by the Russell Storey	15/07/2002		
UNLESS OTHERWISE SPECIFIED DIMENSIONS ARE IN MILLIMETRES			
TOLERANCES ARE +/- 5mm			
S200W WES Components Fibre Cone Subwoofer Flange = 250x250mm Hole = 220x220mm			
MATERIAL High Density Particle Board with Acoustic Foam Finish Premium Piano Type Black Painted Finish with Wood Veneer Feature Panel			
NEXT ASSY. USED ON			
APPLICATION Audiophile Stereo / Monitor / Home Theatre			
Spike Feet Locations Not Shown Construction Direction			
WES Components			
AUDIOPHILE SUB WOOFER			
CAB1000 / 1002			
SIZE (DWG. NO.)	SCALE XXX:XX CAD FILE: HDS1000_NS.dwg		
A3	SHEET 1 of 1		

***** Note *****
"~" = **Approximate** Only due to cabinet Thickness & may vary from diagram with thickness of timber wall - XLS1000 = 32mm MDF. Outside Dimension = Inside + Eg 32mm MDF