

SASANDU KIT - EXPLODE VIEW

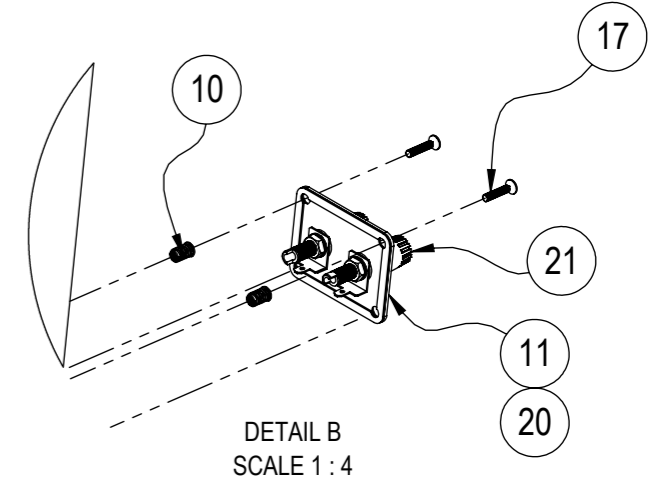

DETAIL B
SCALE 1:4

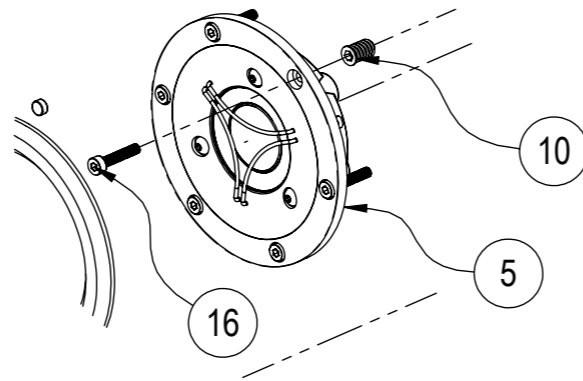
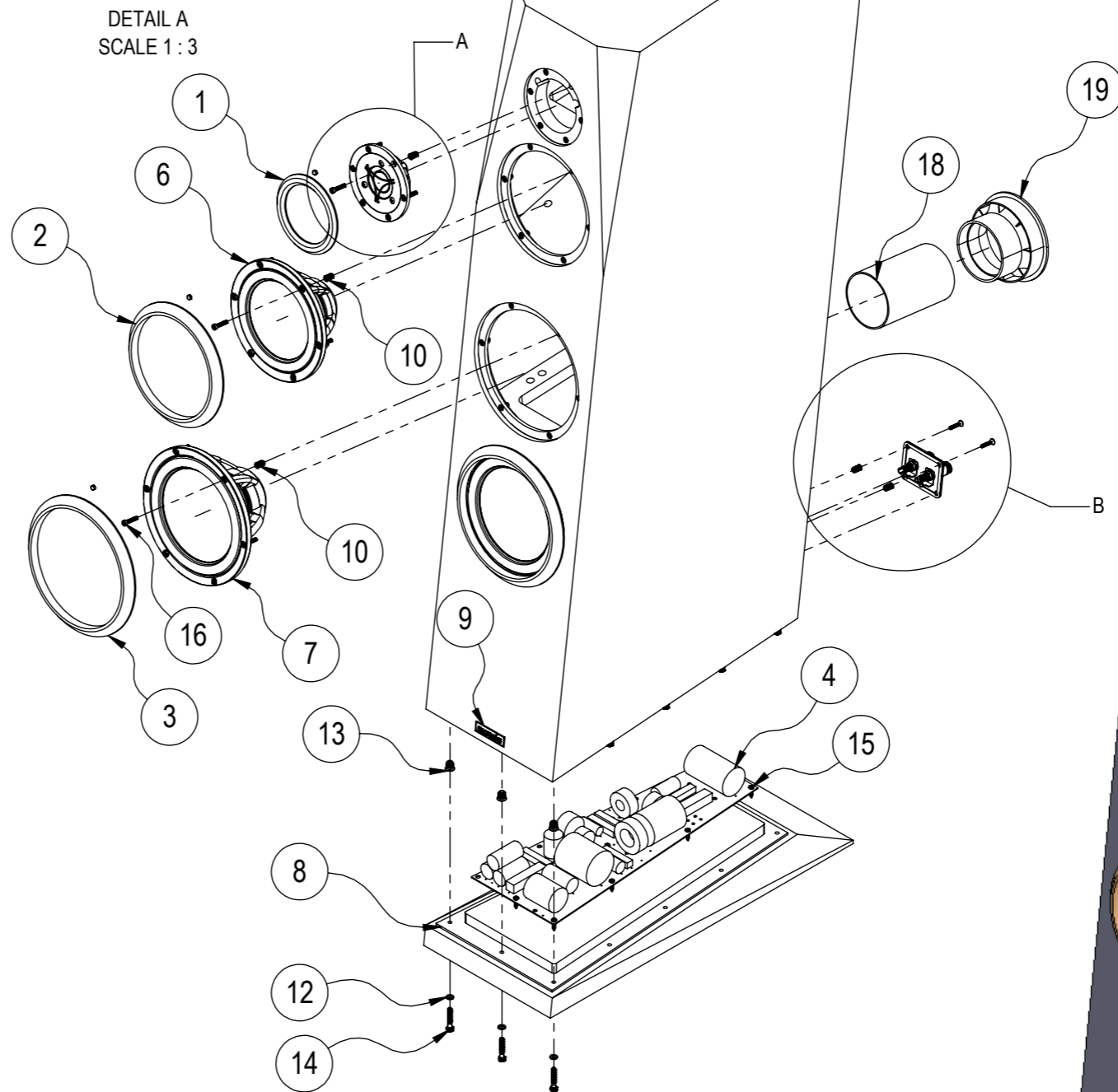

DETAIL A
SCALE 1:3

NO.	DESCRIPTION	QTY.
1	TWEETER GRILL	1
2	MIDRANGE GRILL	1
3	WOOFER GRILL	2
4	A. SASANDU CROSSOVER	1
	B. SASANDU TX CROSSOVER	
5	A. SATORI TW29BN-B-8	1
	B. SATORI TW29TXN-B-8	
6	A. 6.5IN SATORI MR16P-4	1
	B. 6.5IN SATORI MW16TX-4	
7	A. 7.5IN SATORI MW19P-8	2
	B. 7.5IN SATORI MW19TX-8	
8	SEAL GASKET (FOR PEDESTAL, INSTALLED ON CABINET)	2
9	NAME PLATE	1
10	INSERT NUT M4 (INSTALLED)	28
11	STAINLESS TERMINAL PLATE	1
12	WASHER PLATE (INSTALLED)	11
13	INSERT NUT M5 (INSTALLED)	11
14	SR-MSIH-5X30-BLK CR3+	11
15	WOOD SCREW 4 X 16 mm FOR CROSSOVER (FROM KIT CROSSOVER)	10
16	HEX SOCKET SCREW M4 X 20mm (FOR DRIVERS)	24
17	COUNTERSUNK SCREW M4 X 20mm (FOR TERMINAL PLATE)	4
18	PAPER TUBE D:75mm L:100mm (INSTALLED ON CABINET)	1
19	PORT FLARE D:75mm (INSTALLED ON CABINET)	1
20	SEAL GASKET (FOR TERMINAL PLATE)	1
21	BINDING POST	1

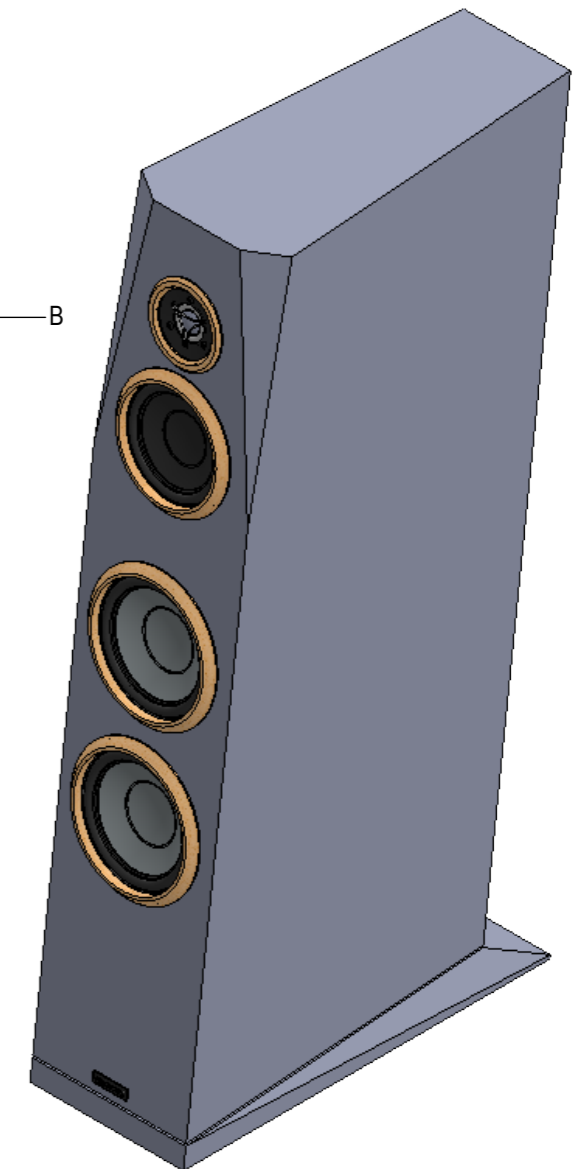

DAMPING MATERIAL A
 Dacron 90oz White Color T20mm
 Size: 430 x 125 x 430 x 185 mm
 (2 layers covering the top brace behind tweeter)

DAMPING MATERIAL B
 Dacron 90oz White Color T20mm
 Size : 485 x 125 x 485 x 190 mm
 (1 layer on the partition (bottom of midrange chamber))

DAMPING MATERIAL G
 Dacron 90oz White Color T20mm
 Size: 485 x 125 x 485 x 190 mm
 (2 layers in top of upper section woofer chamber (lower layer may rest on the brace between the side walls as shown))

DAMPING MATERIAL H
 Dacron 90oz White Color T20mm
 Size: 240 x 225 x 220 x 280 mm
 (1 layer on each side wall in front half of upper section in woofer chamber)

DAMPING MATERIAL J
 Dacron 90oz White Color T20mm
 Size: 445 x 210 x 445 x 210 mm
 (1 layer on each side in center section of woofer chamber)

DAMPING MATERIAL I
 Dacron 90oz White Color T20mm
 Size: 445 x 125 x 445 x 210 mm
 (2 layers on entire lower brace in woofer chamber (must stay in place))

DAMPING MATERIAL D
 Dacron 90oz White Color T20mm
 Size: 65 x 125 mm
 (2 layers on black wall of midrange chamber (below the brace only))

DAMPING MATERIAL C
 Dacron 90oz White Color T20mm
 Size: 445 x 185 x 485 x 75 mm
 (1 layer on each side in the midrange chamber (below the brace only))

DAMPING MATERIAL E
 Dacron 90oz White Color T20mm
 Size: 330 x 125 mm
 (2 layers on back wall in upper section of woofer chamber)

DAMPING MATERIAL F
 Dacron 90oz White Color T20mm
 Size: 220 x 125 x 220 x 160 mm
 (1 layer on back half of upper brace in upper section of woofer chamber)

DAMPING MATERIAL L
 Dacron 90oz White Color T20mm
 Size: 110 x 125 mm
 (1 folded piece above port in the back)

DAMPING MATERIAL K
 Dacron 90oz White Color T20mm
 Size: 90 x 125 mm
 (1 folded piece below port in the back)

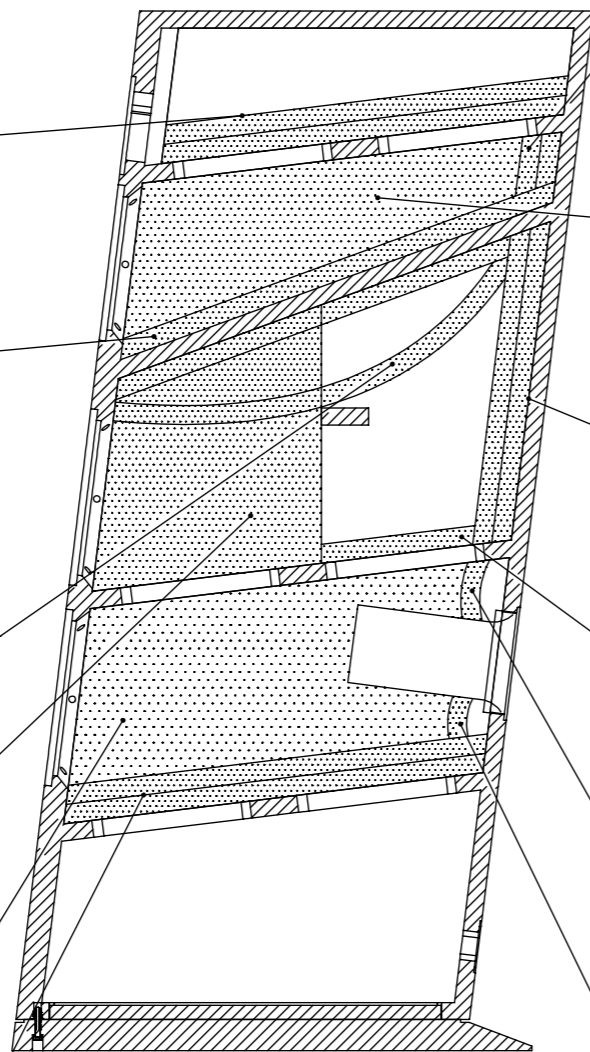

SECTION A-A
 SCALE 1 : 8

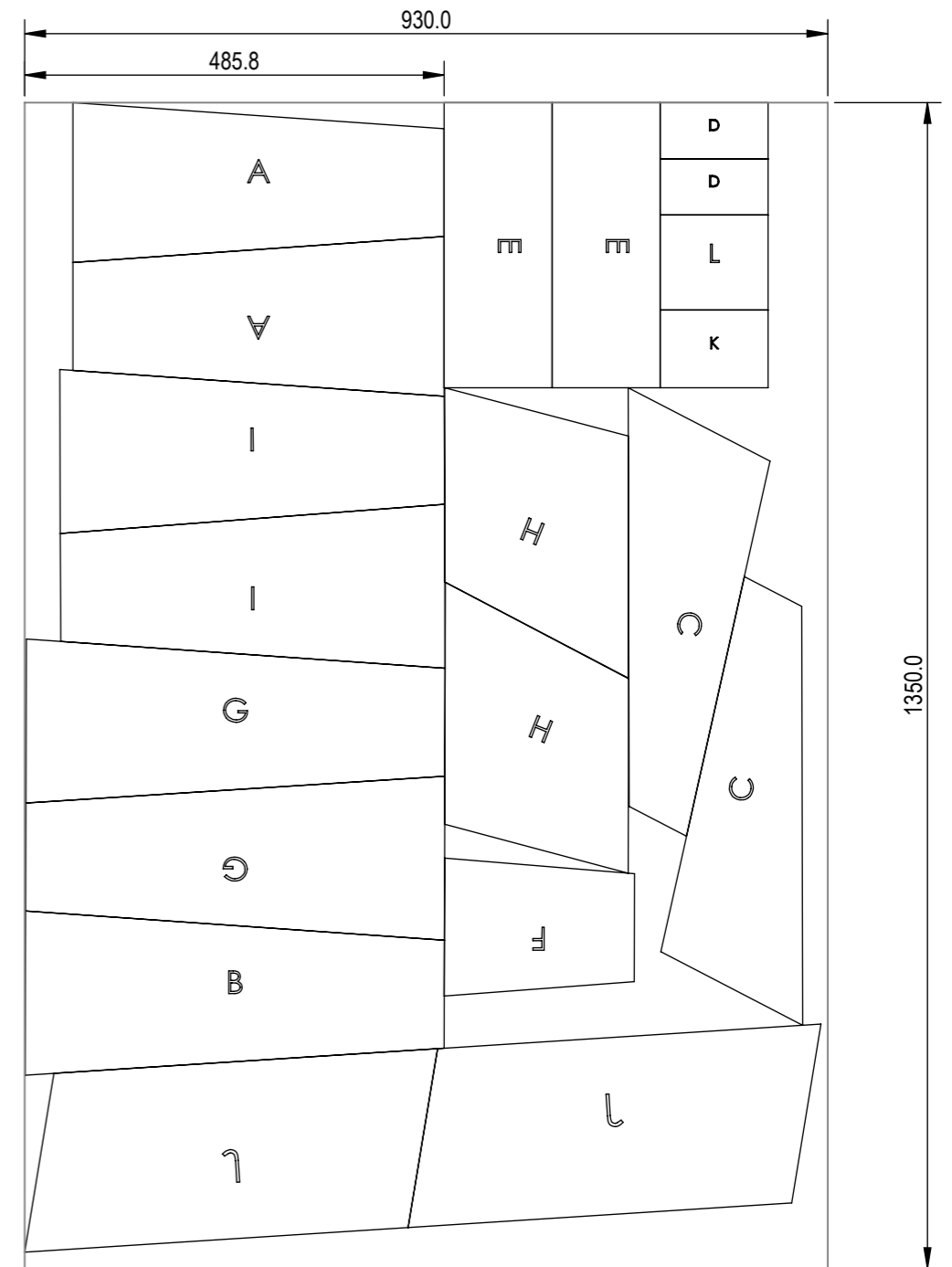

"DAMPING MATERIAL CUT PATTERN"

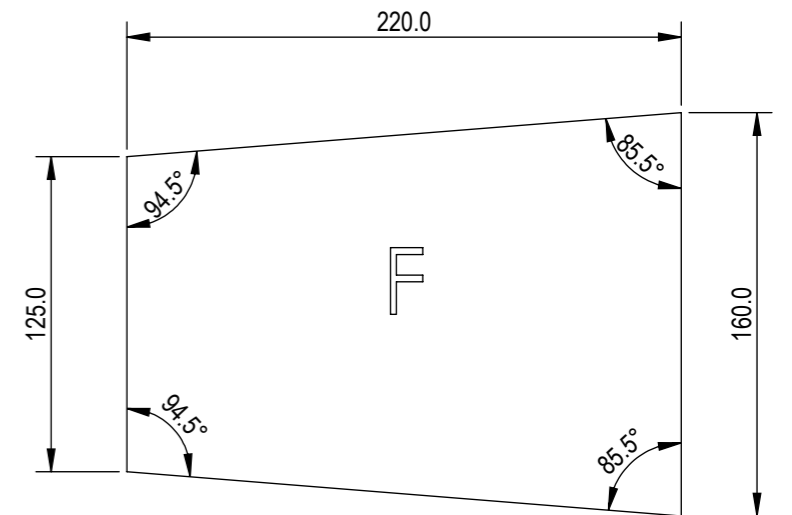
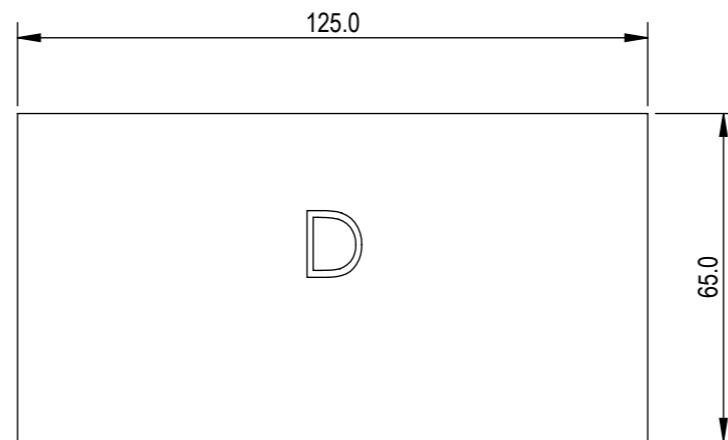
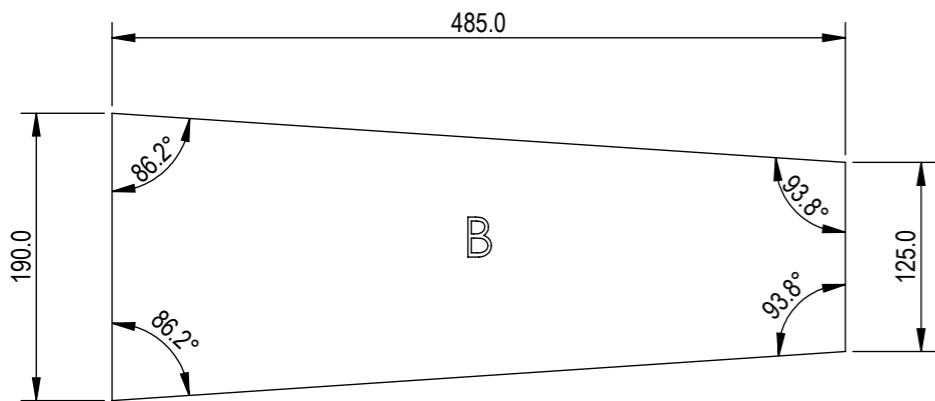
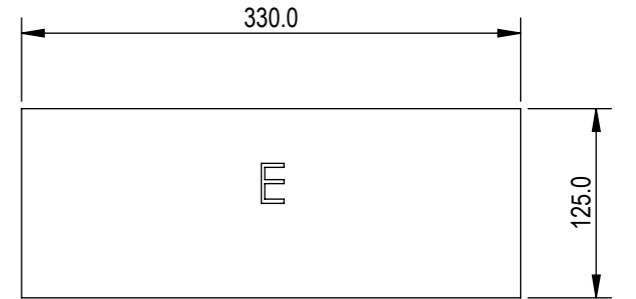
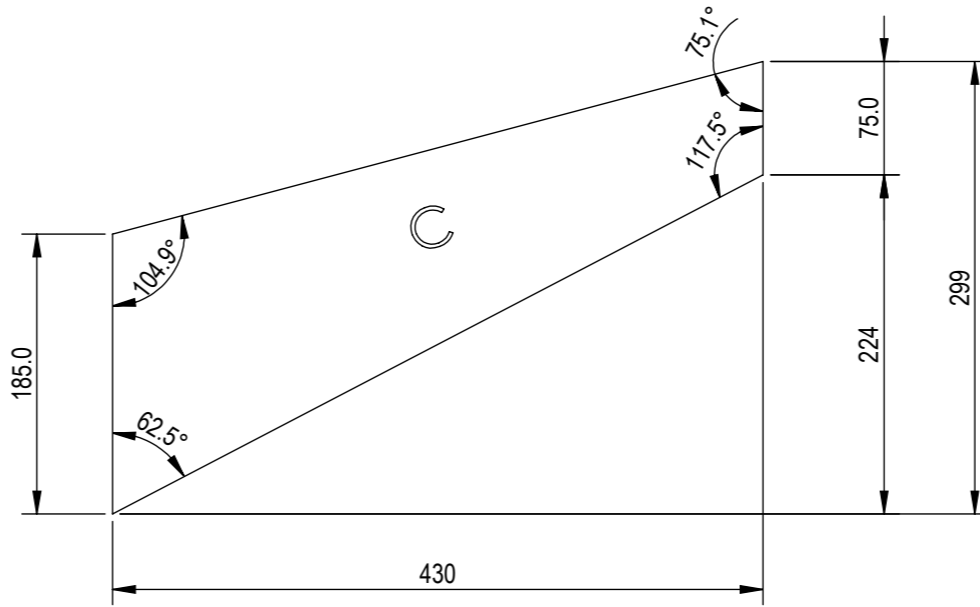
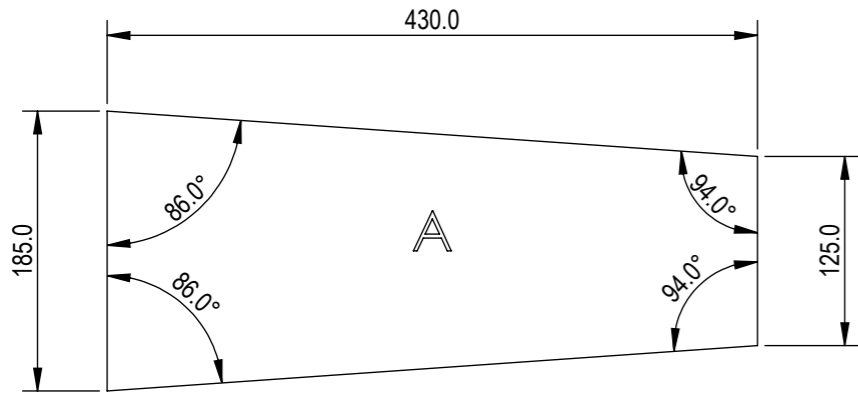

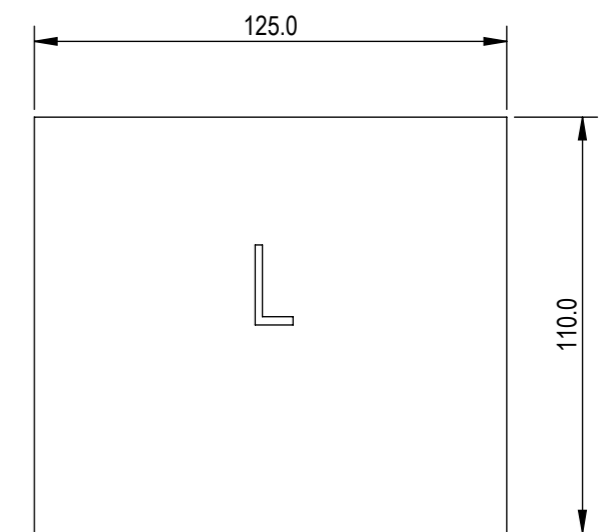
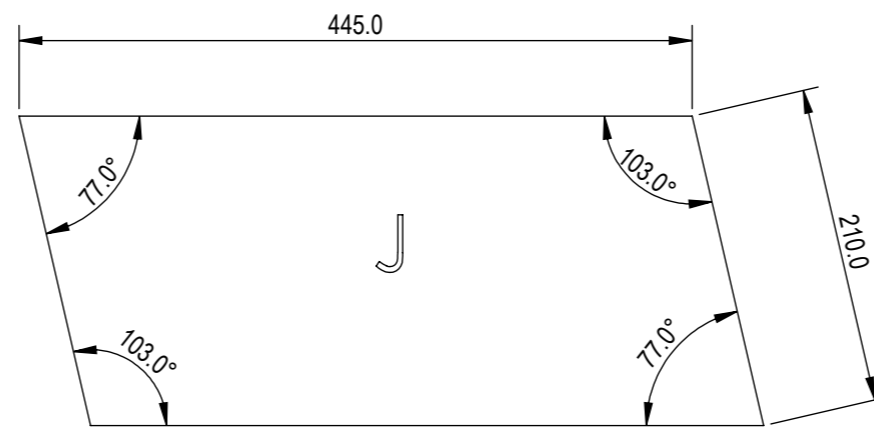
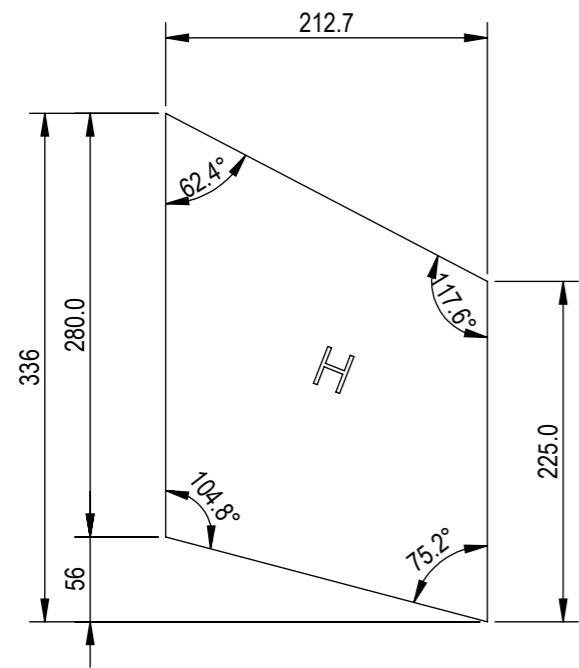
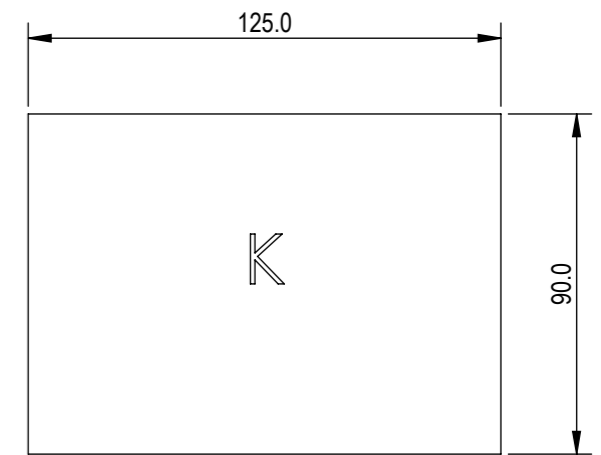
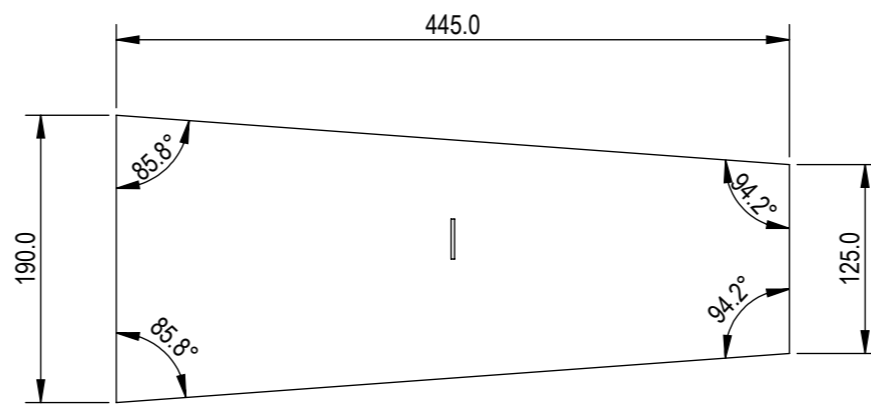
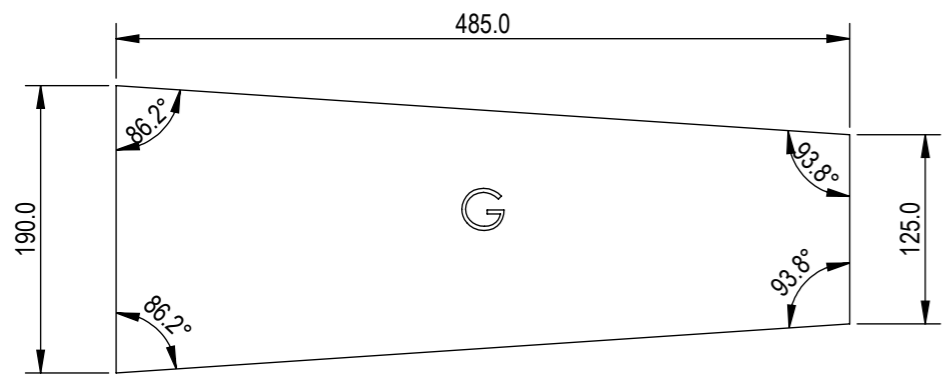

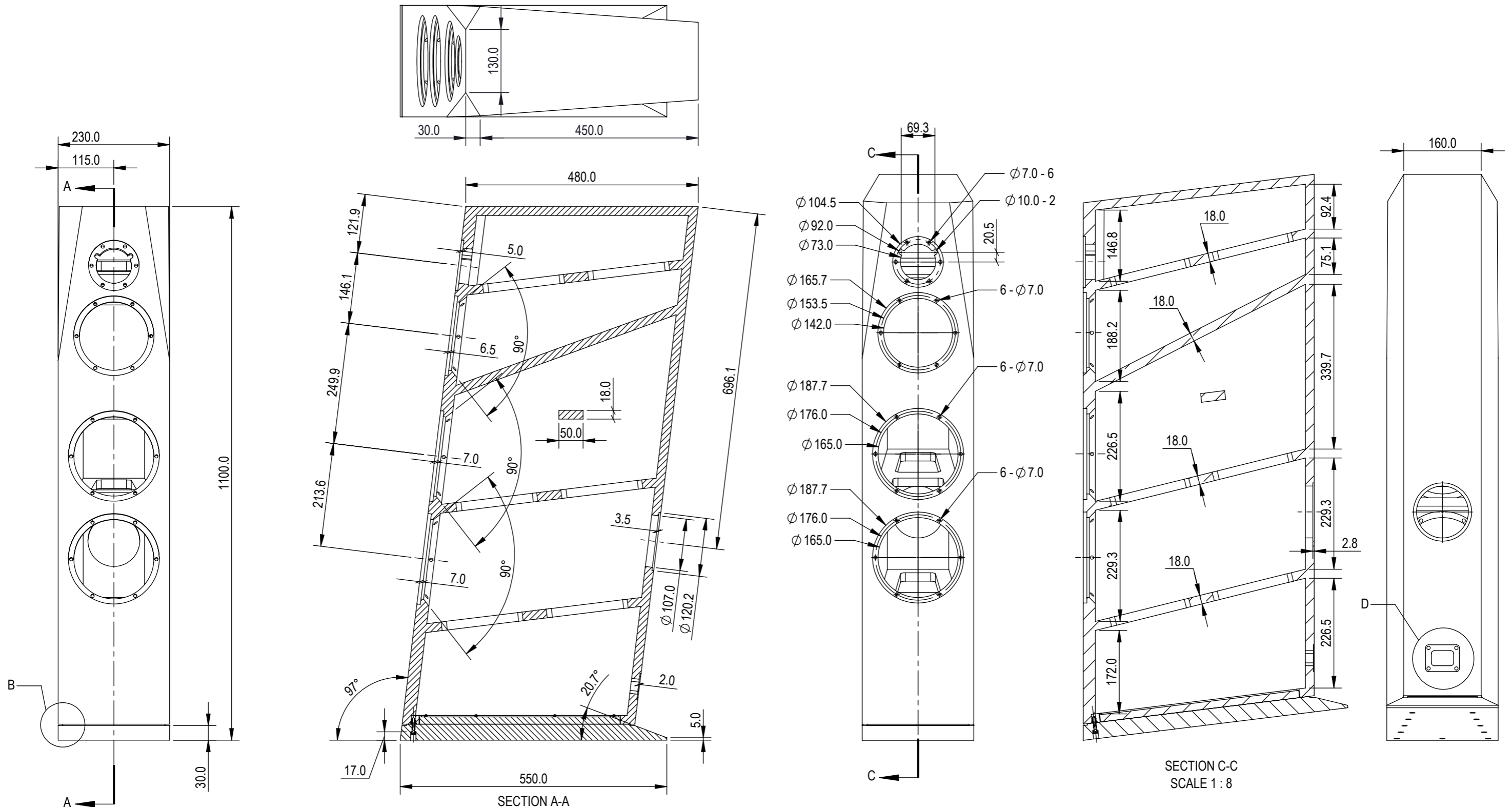

NOTE:

- All dimensions are before painting except depth
- Depth dimensions after painting could be same with drawing
- There is no defect on painting
- Paint thickness assumed 0.5 mm

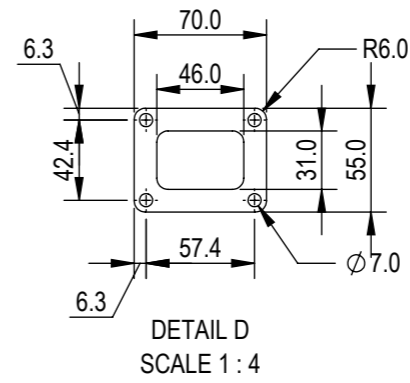
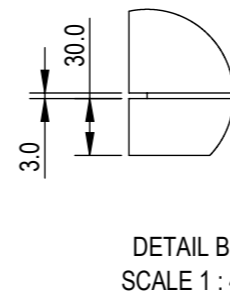
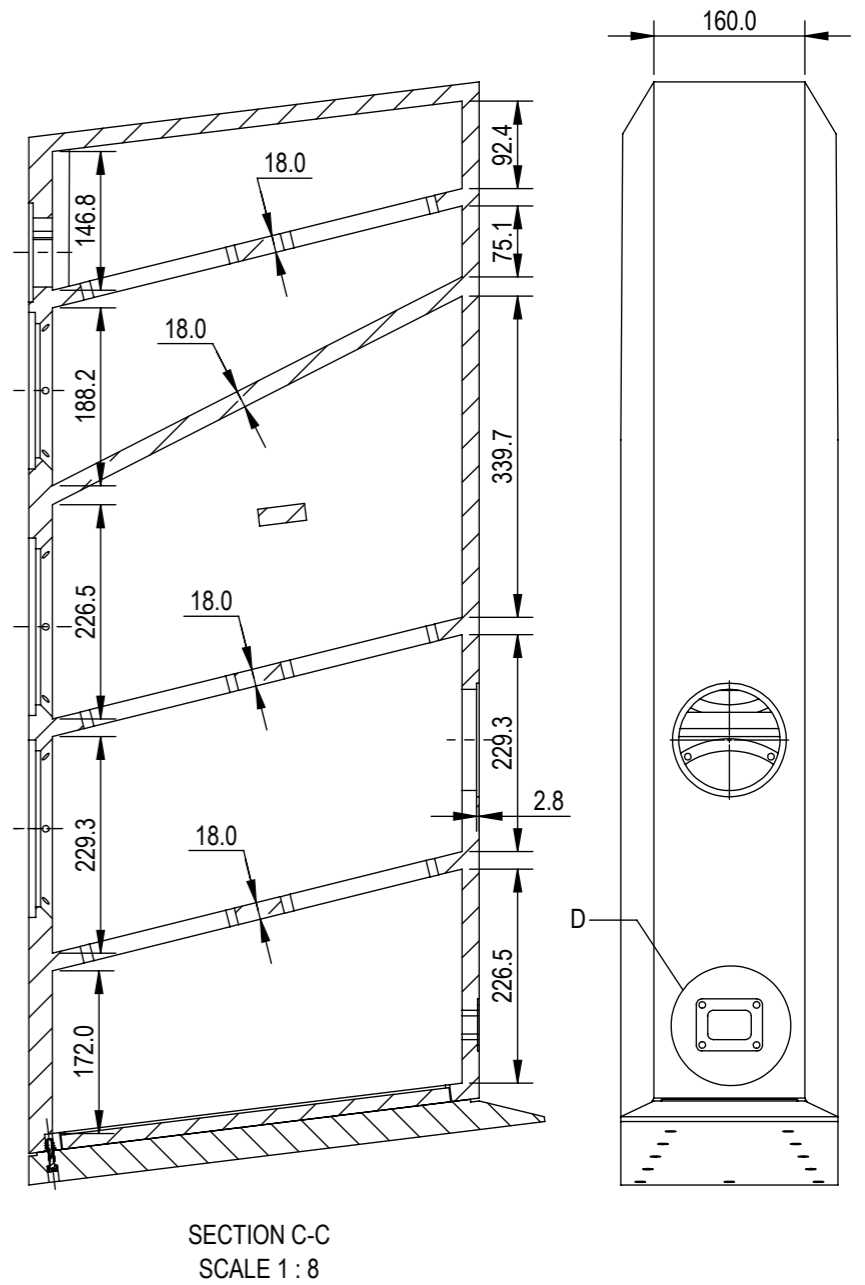
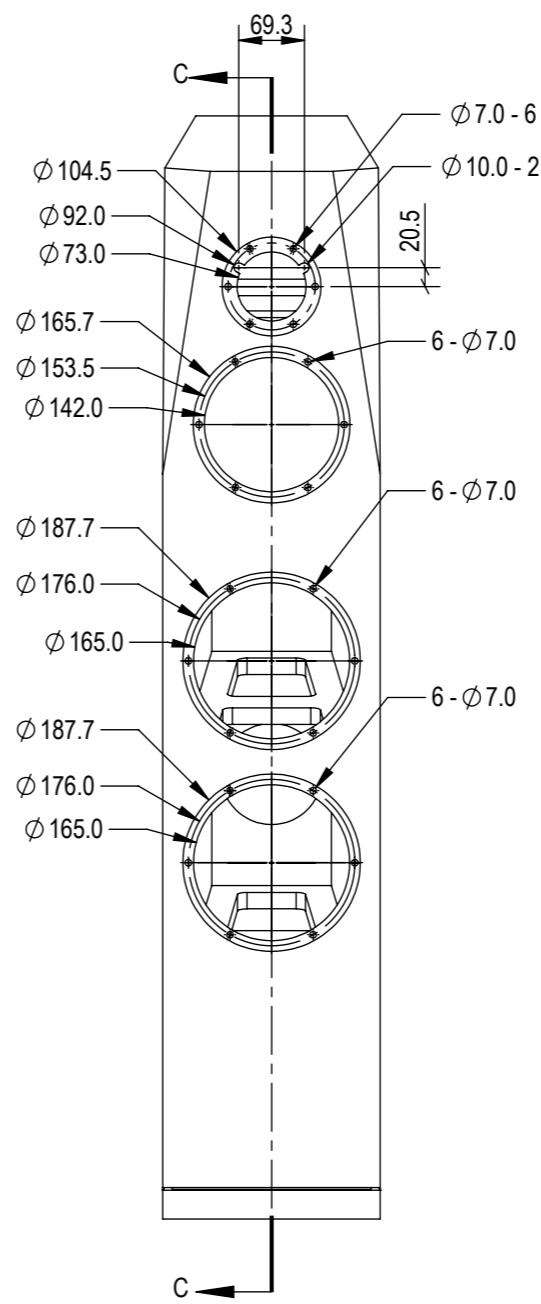
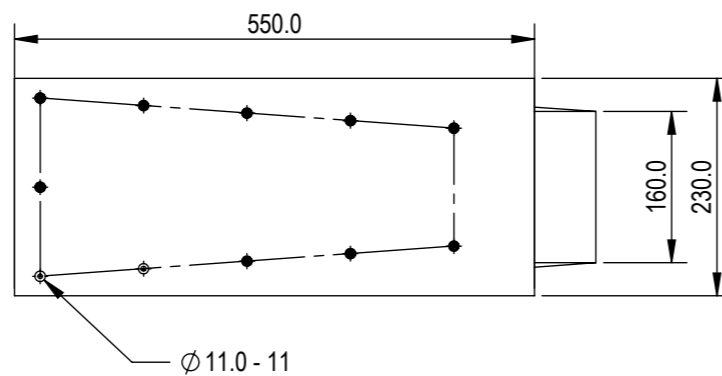

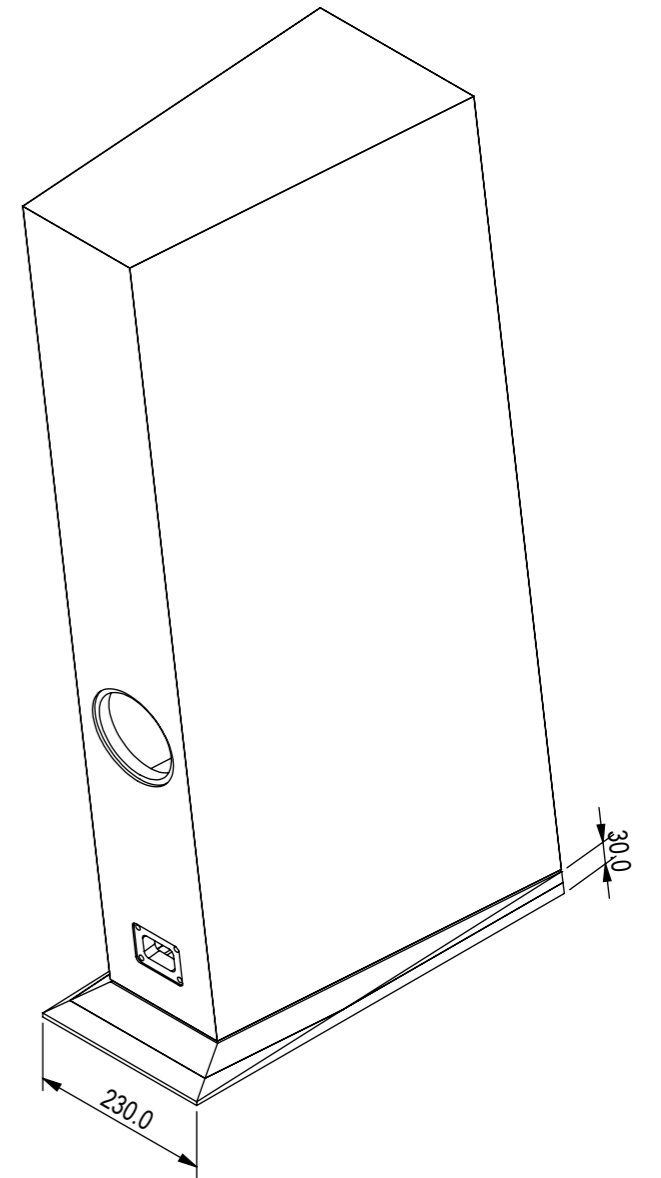
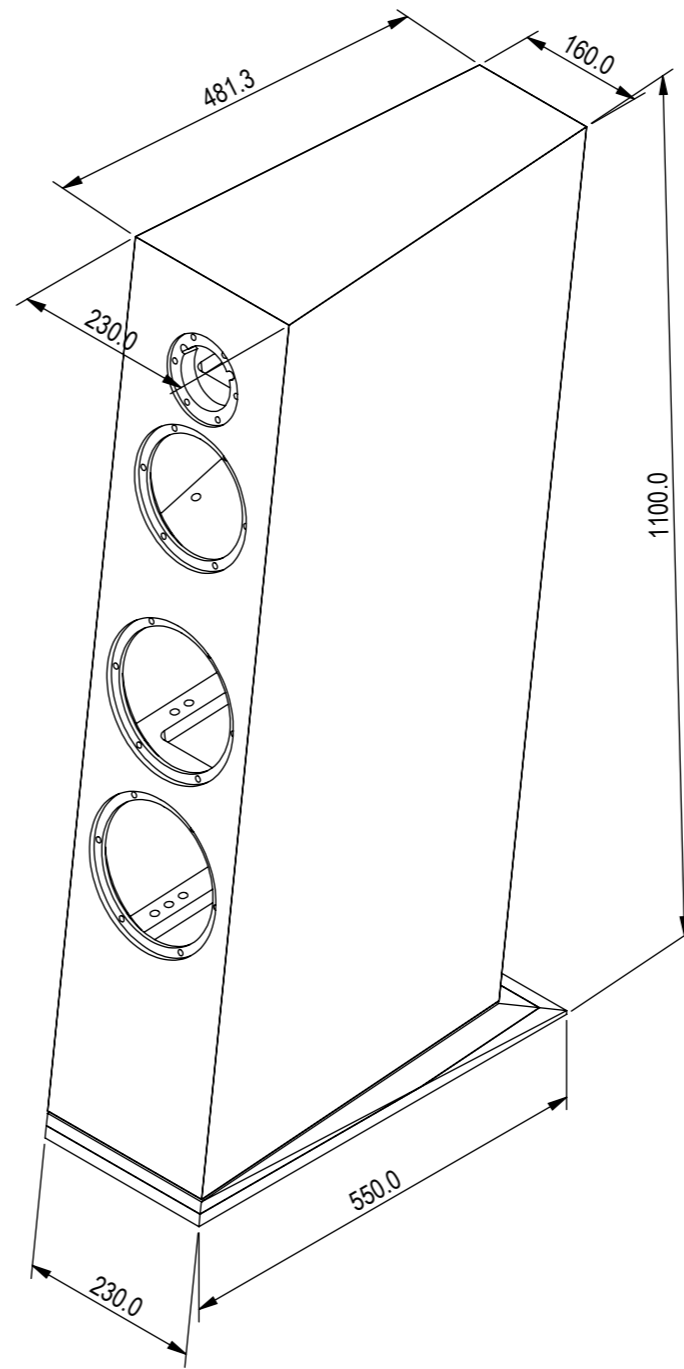
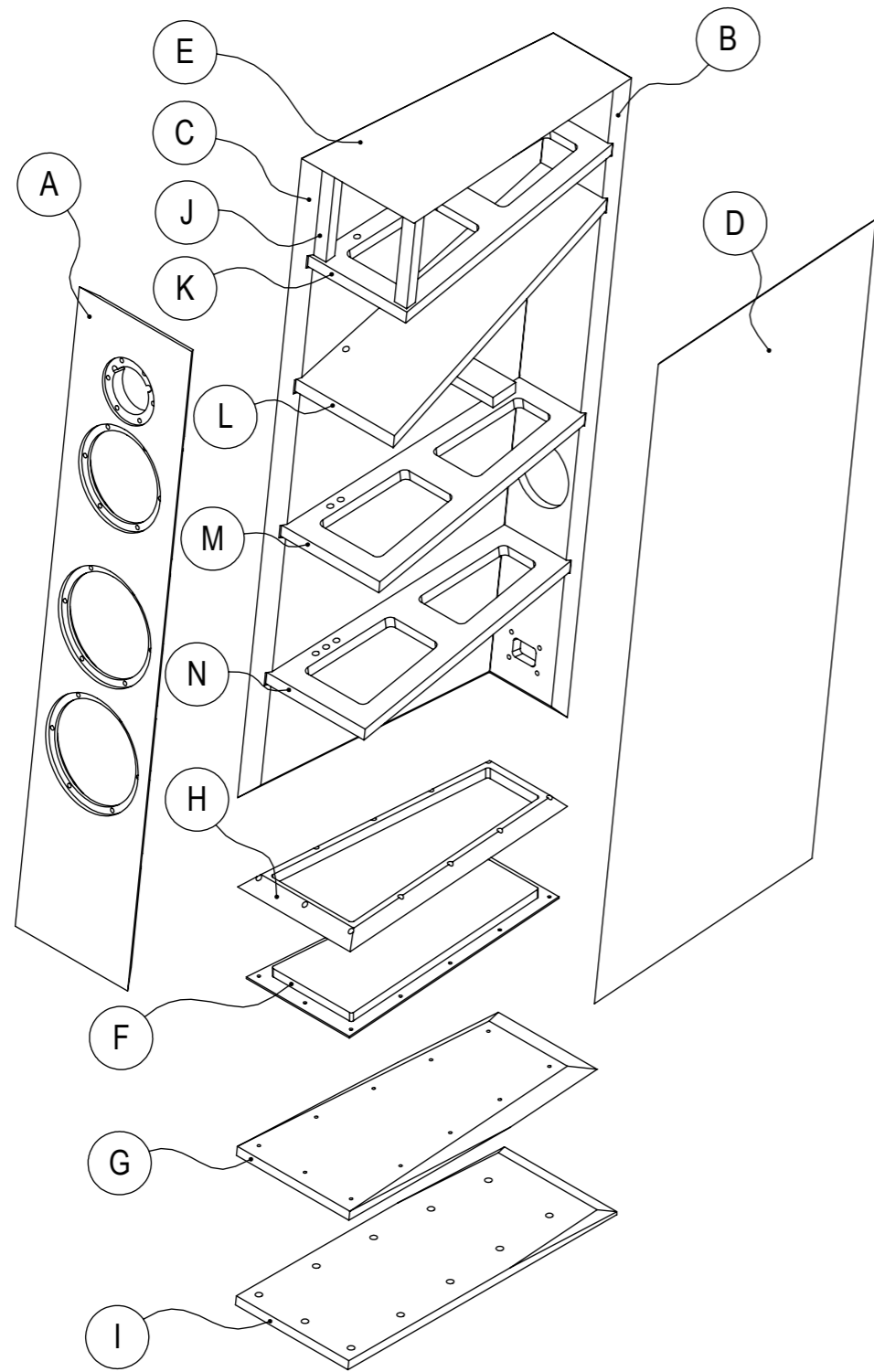

BOARD (A)

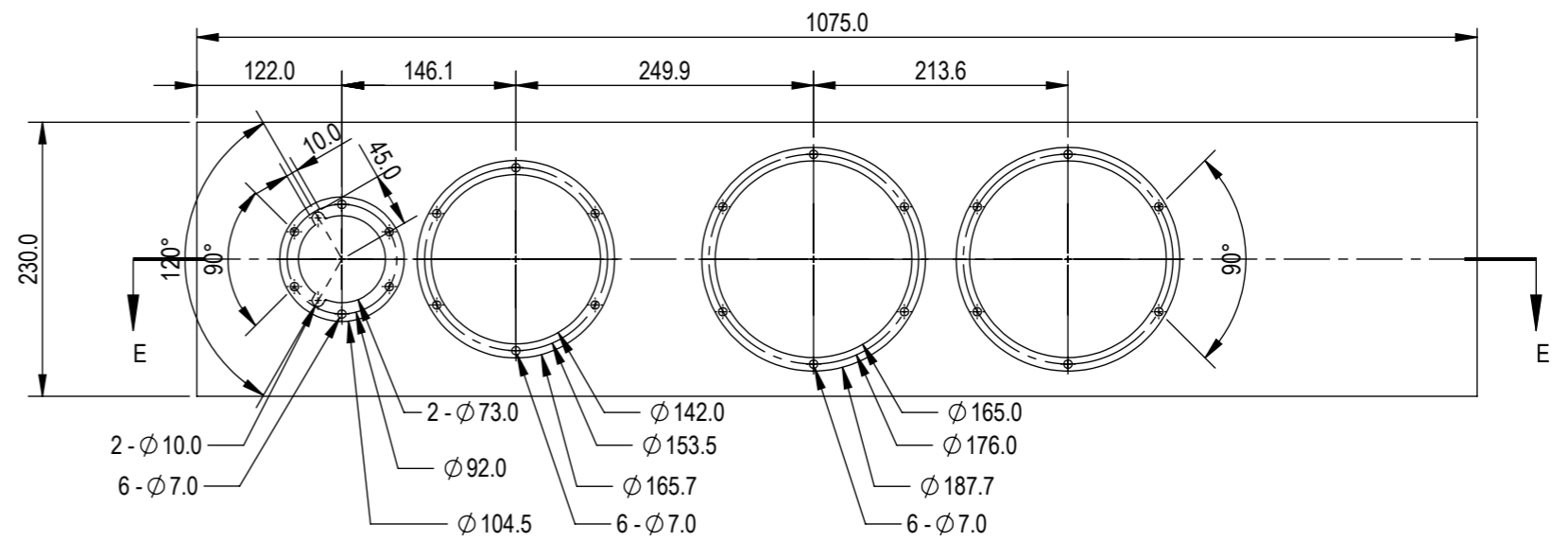
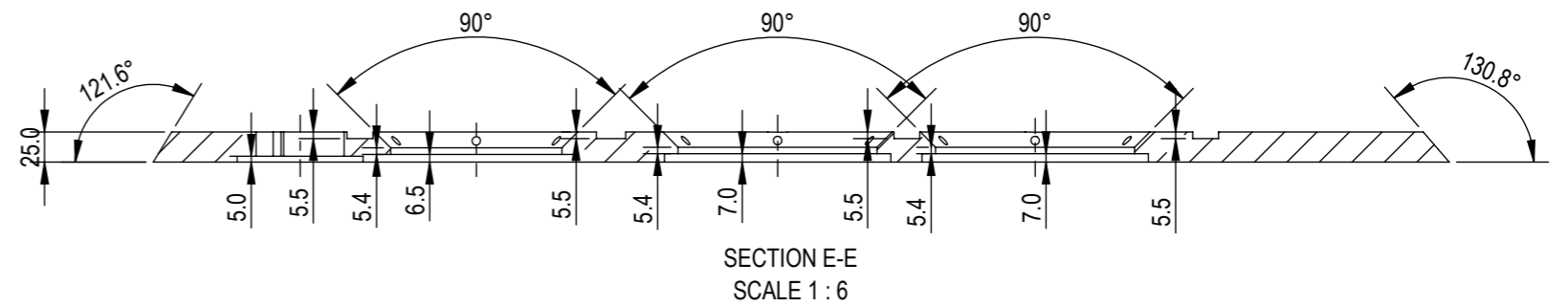
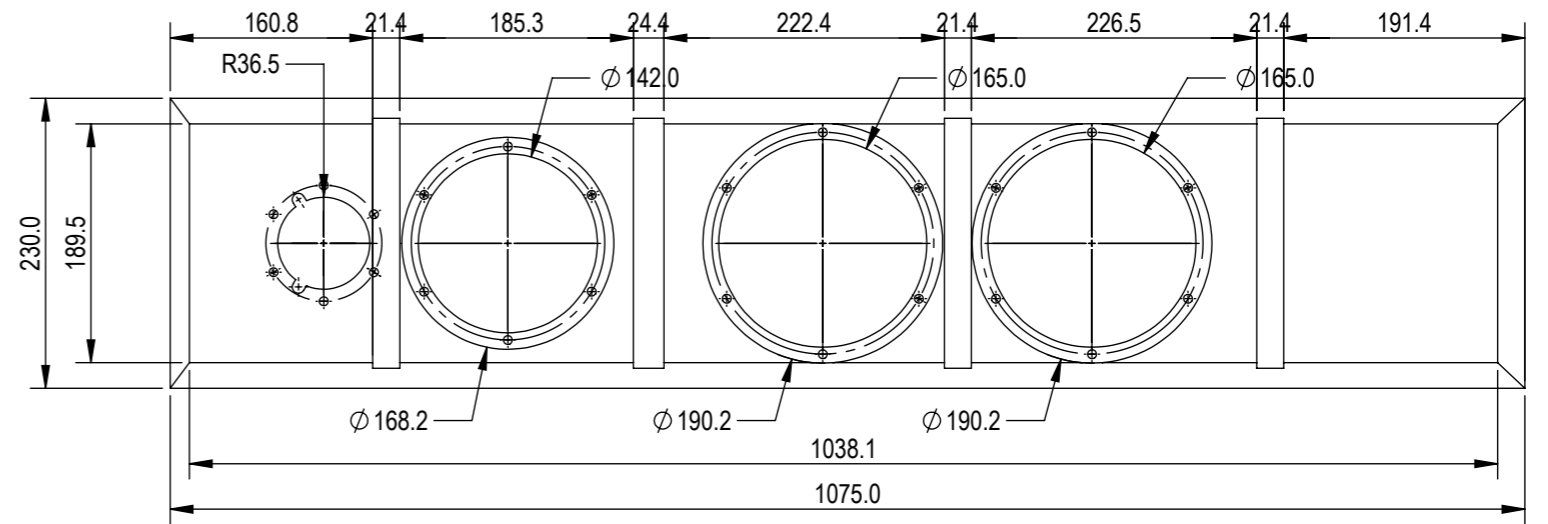
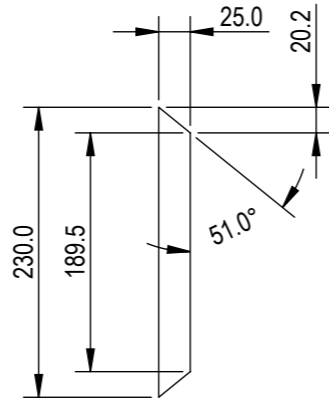
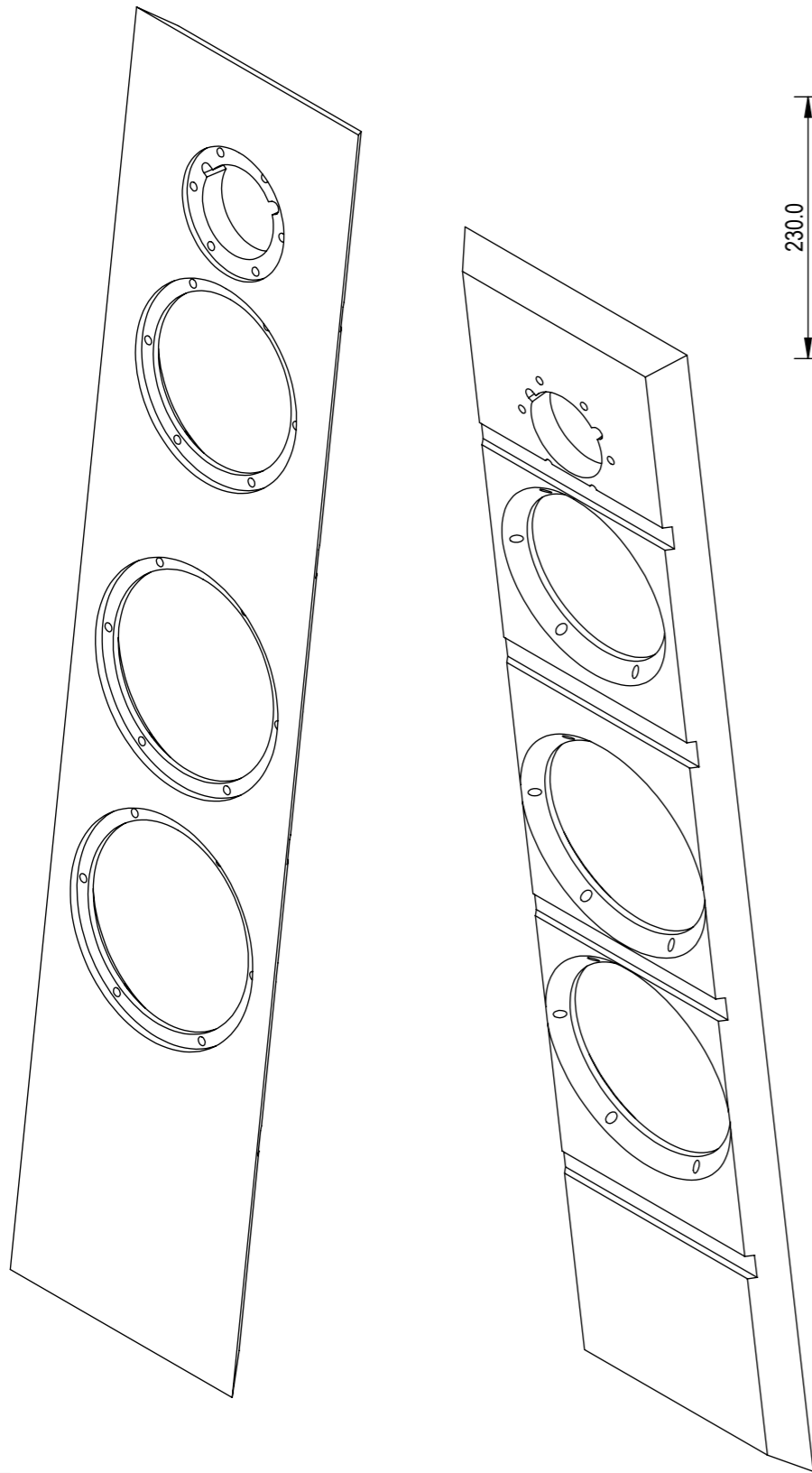

NOTE:

- All dimensions are before painting except depth
- Depth dimensions after painting could be same with drawing
- There is no defect on painting
- Paint thickness assumed 0.5 mm

BOARD (B)

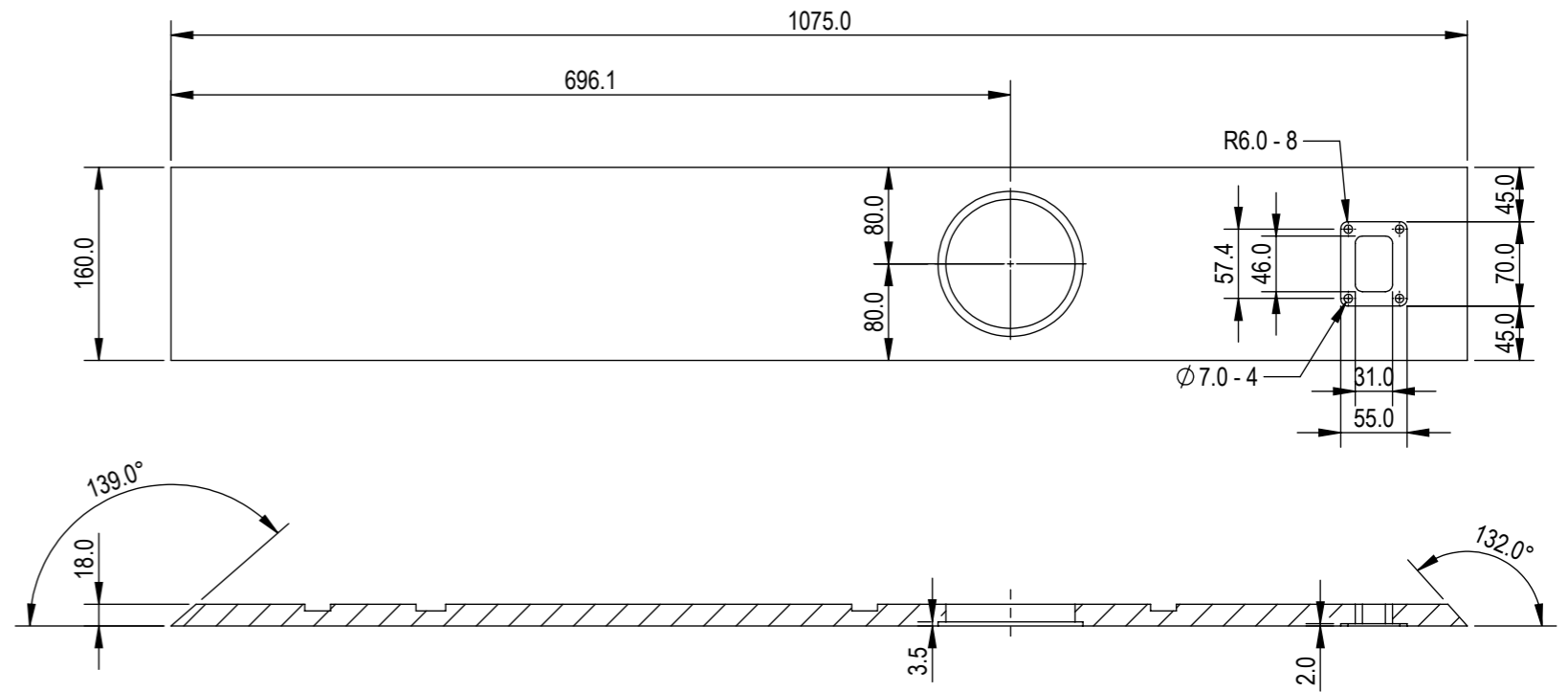
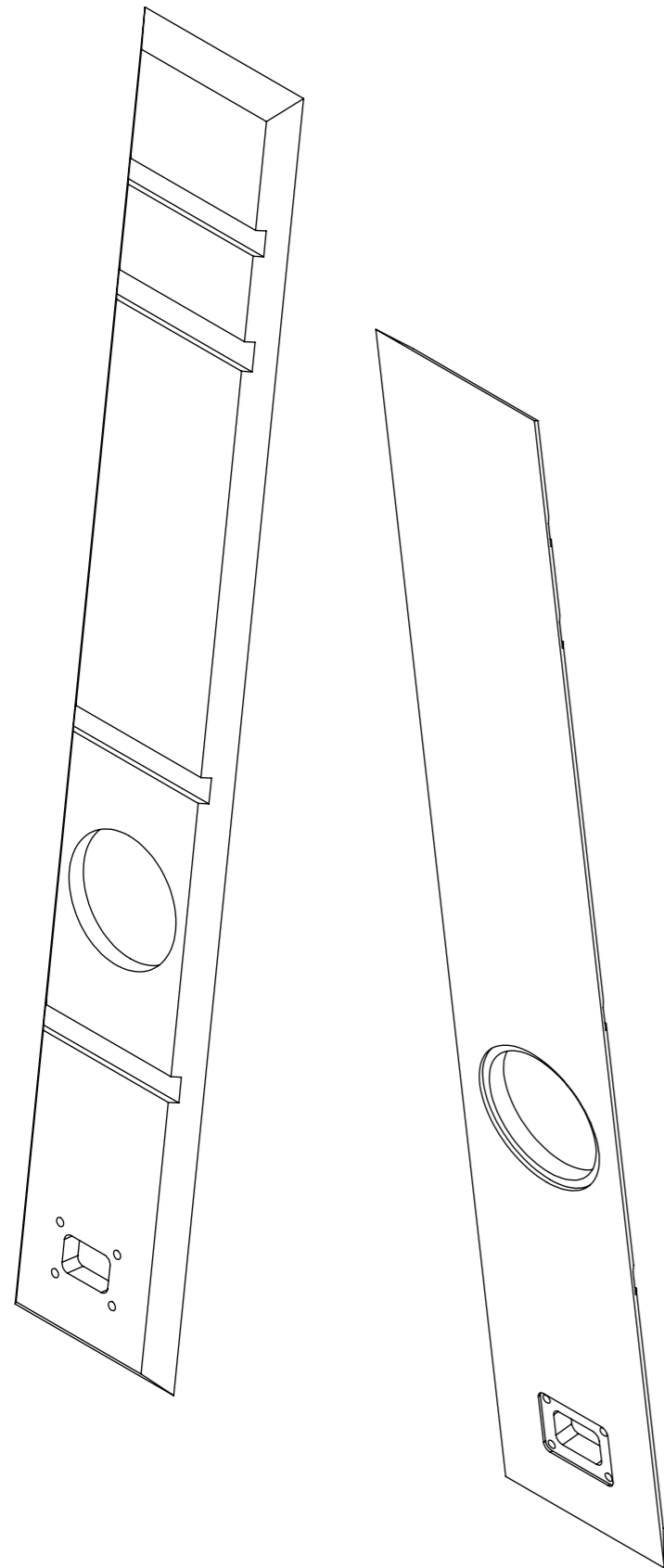

SECTION F-F
SCALE 1 : 6

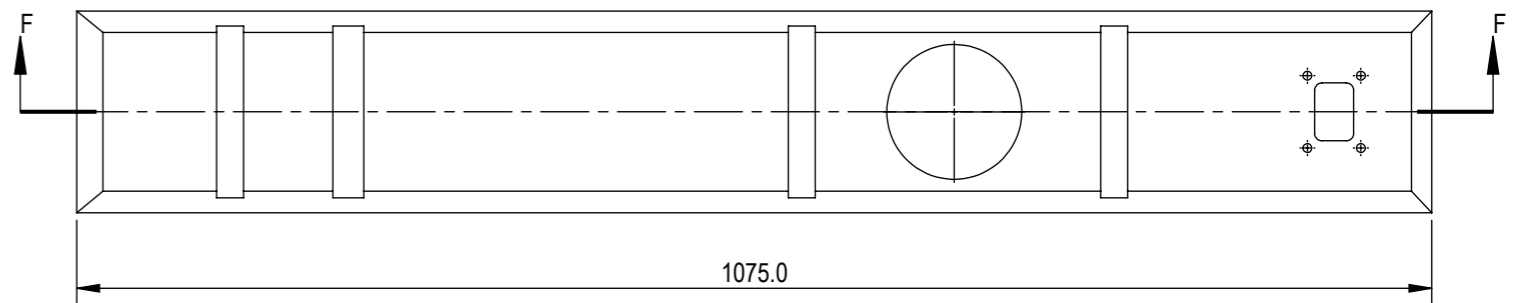
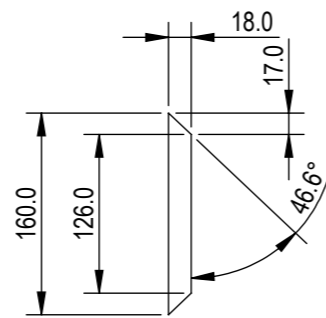

- NOTE:
- All dimensions are before painting except depth
 - Depth dimensions after painting could be same with drawing
 - There is no defect on painting
 - Paint thickness assumed 0.5 mm

BOARD (C) & (D)

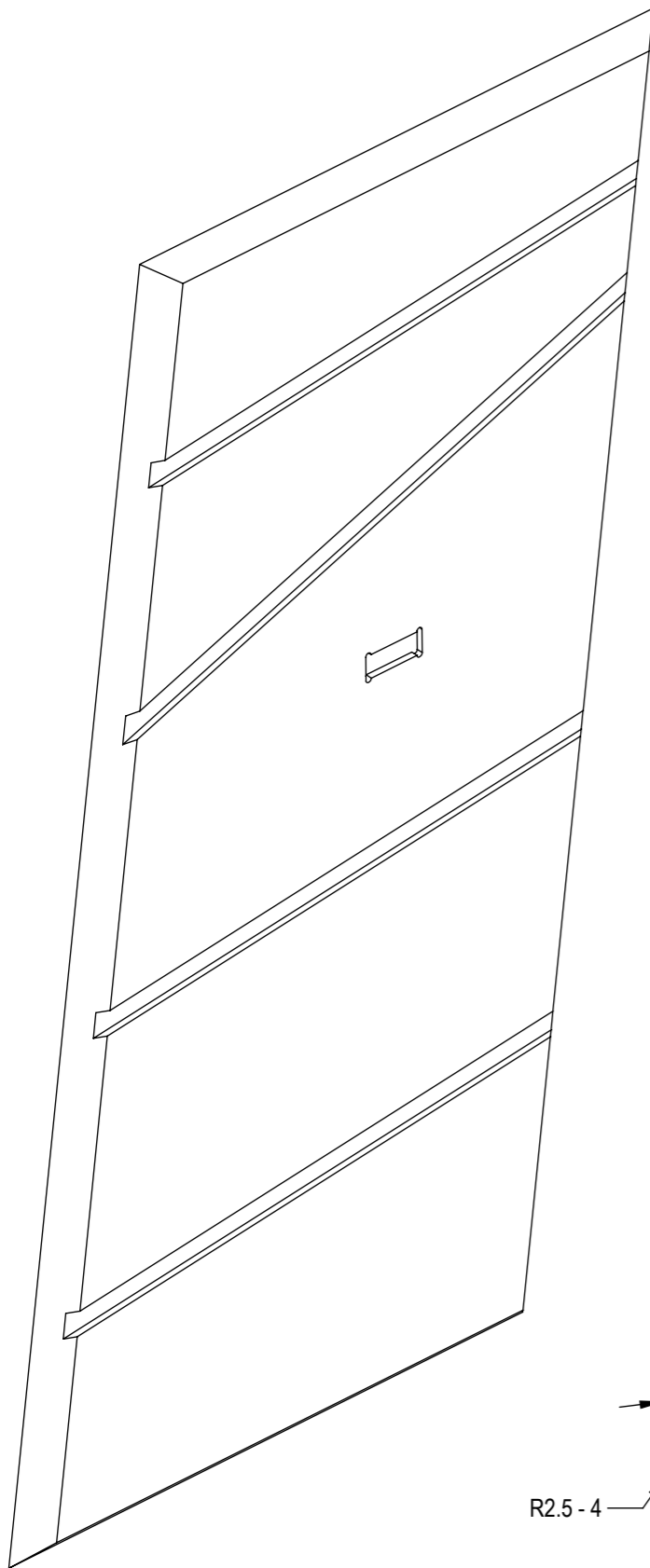

LEFT BOARD SHOWN
RIGHT BOARD IS MIRRORED LEFT BOARD

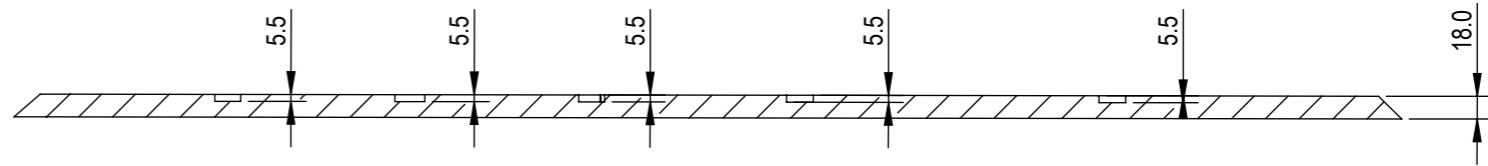

SECTION A-A
SCALE 1:6

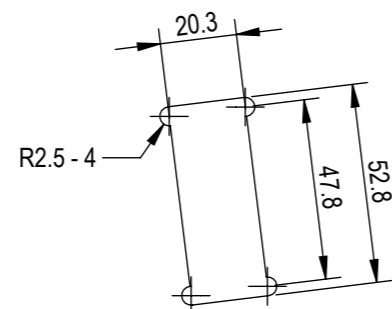
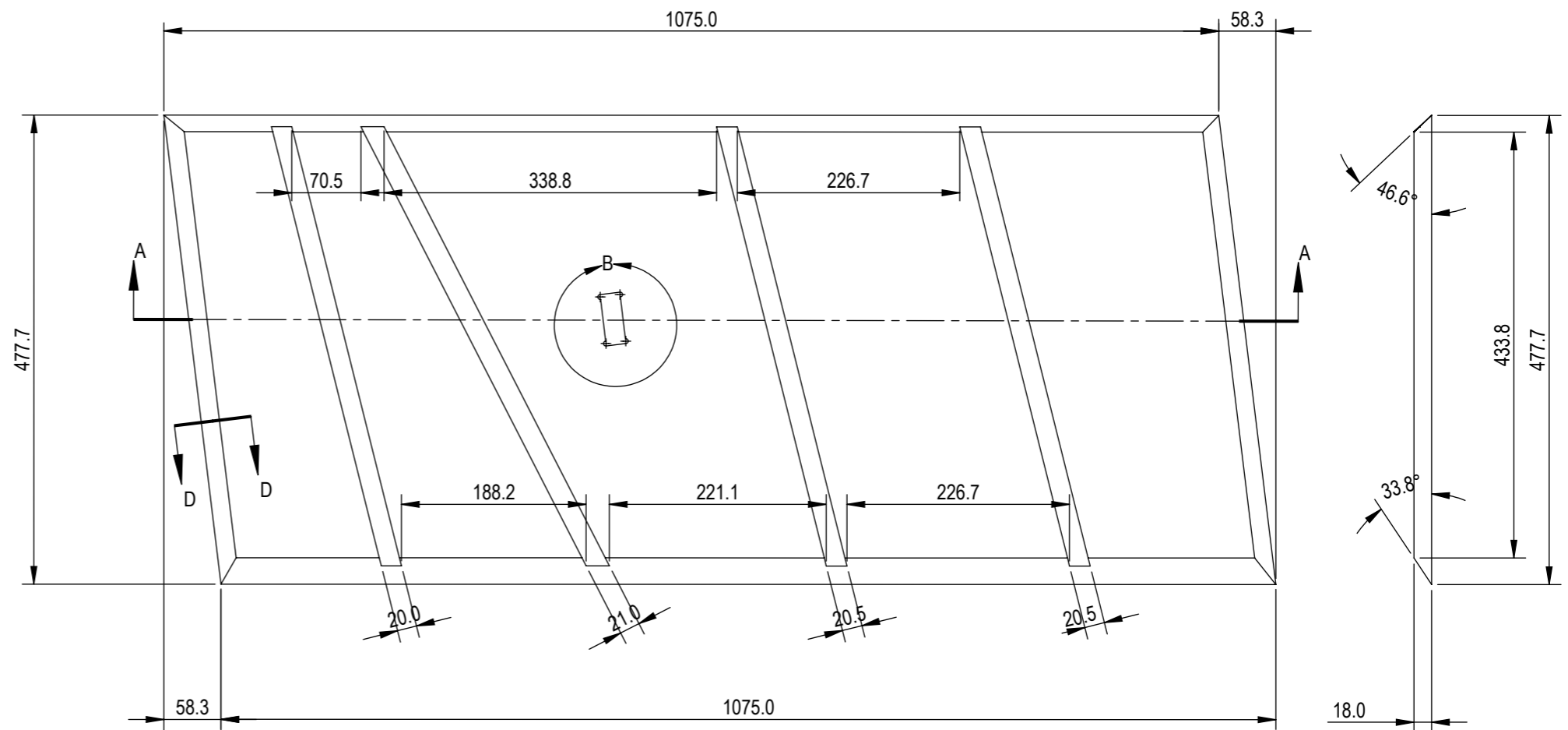

DETAIL B
SCALE 1:2

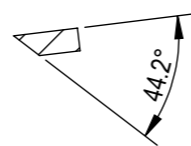

SECTION D-D
SCALE 1:6

BOARD (E)

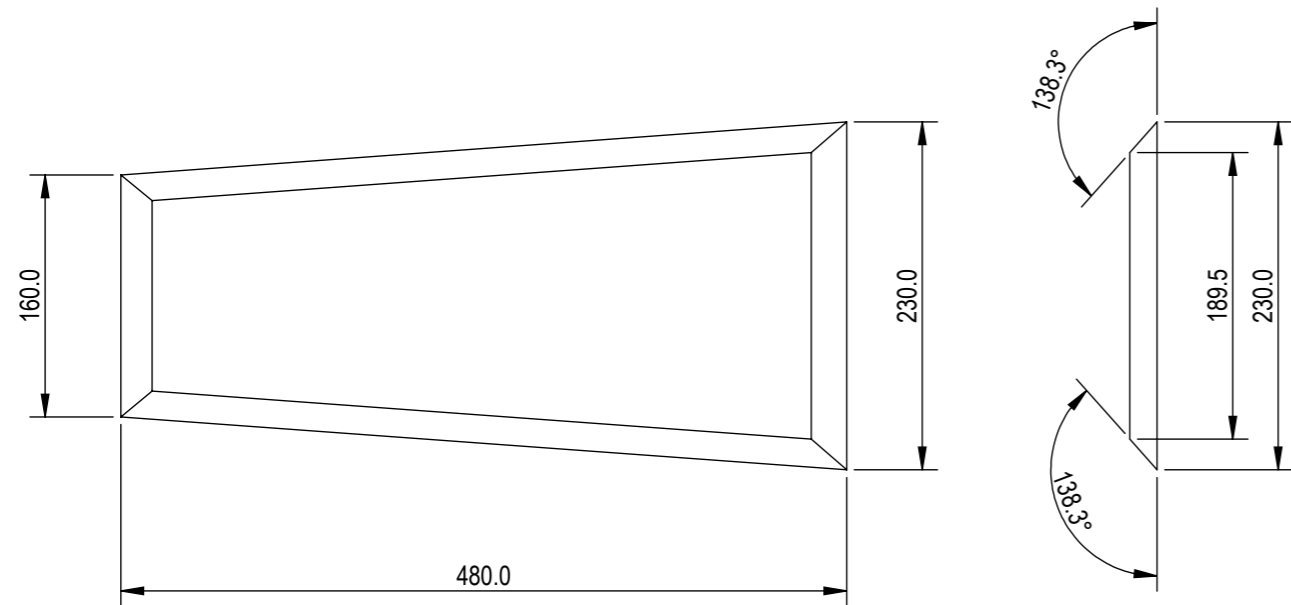
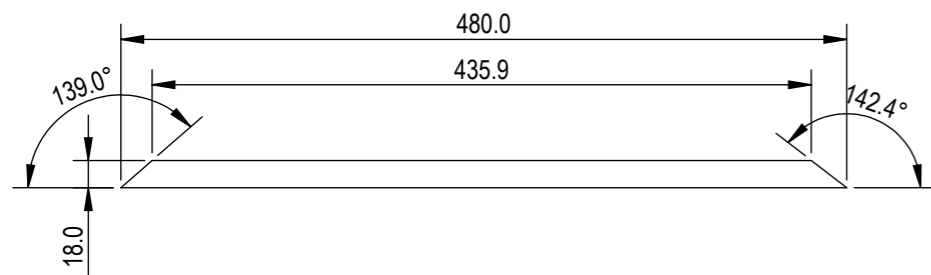
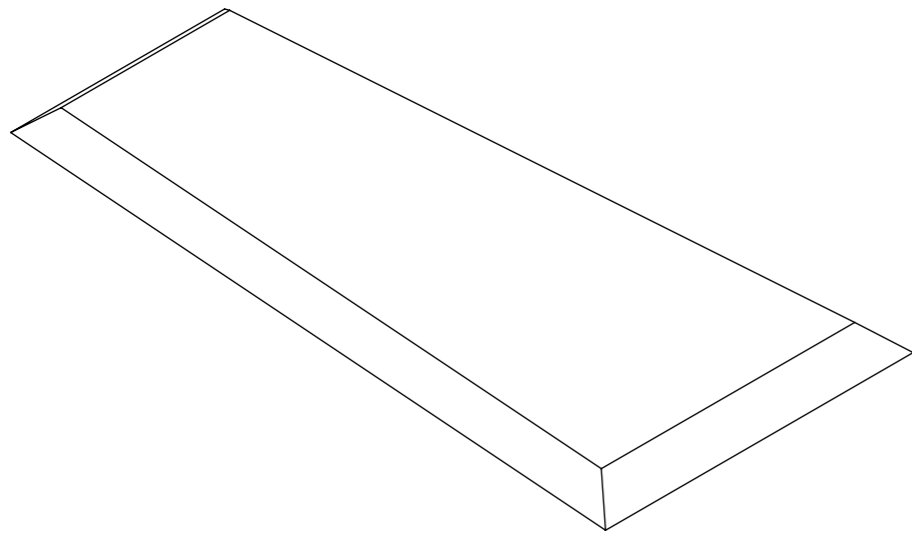

BOARD (F)

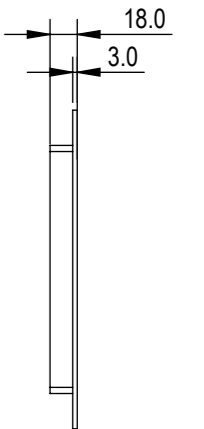
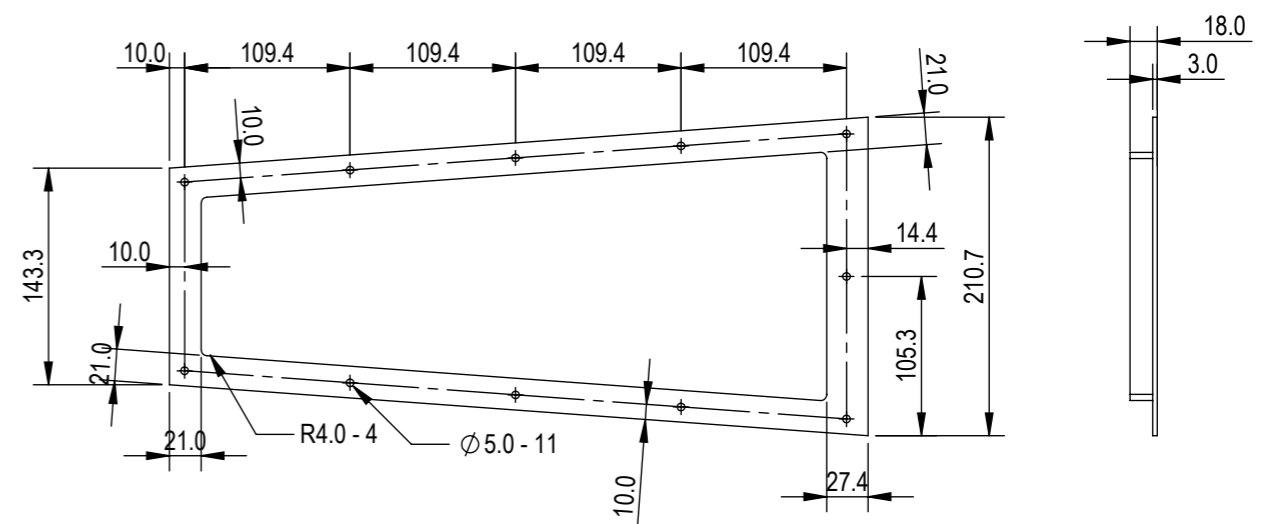
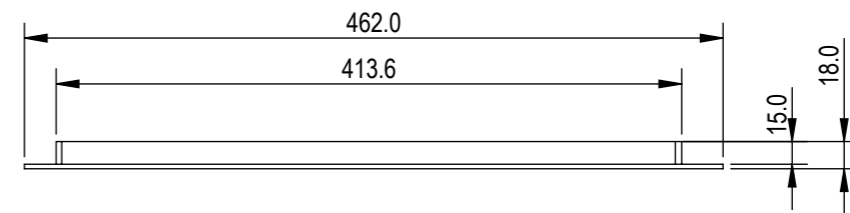
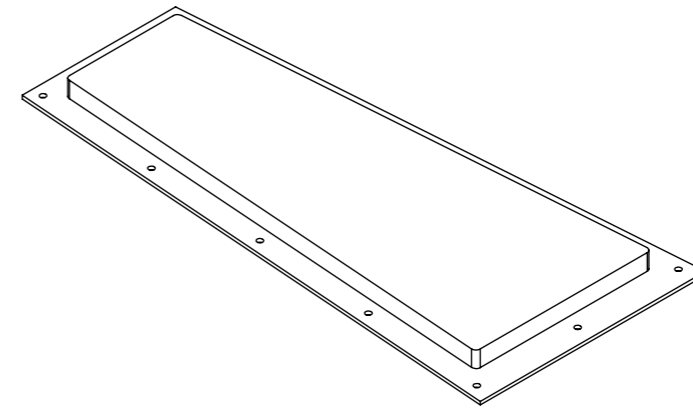

BOARD (G)

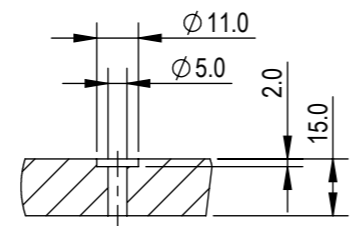
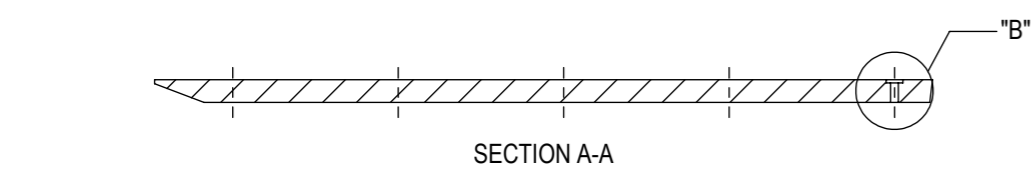
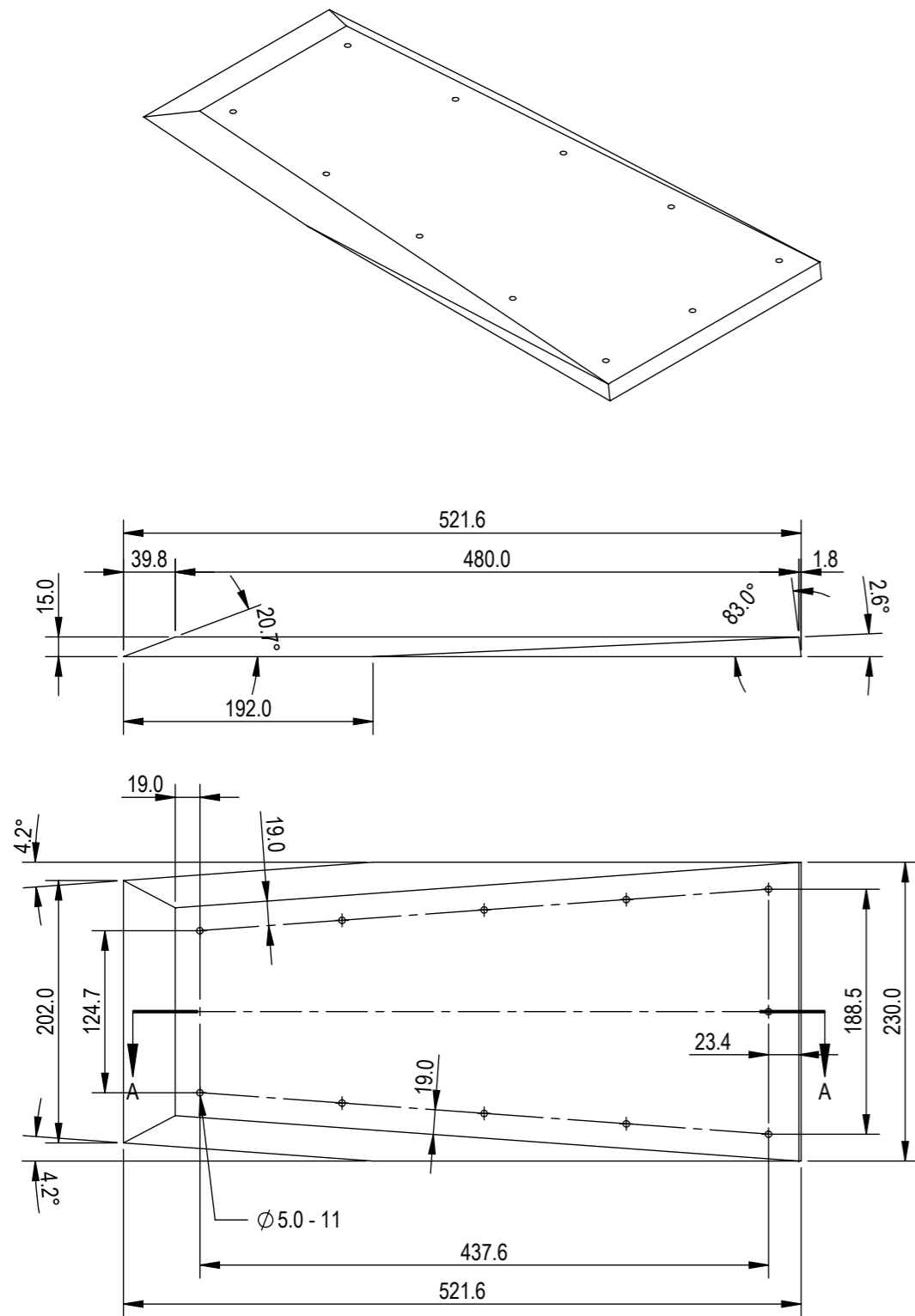

DETAIL "B"
SCALE 1:2

BOARD (H)

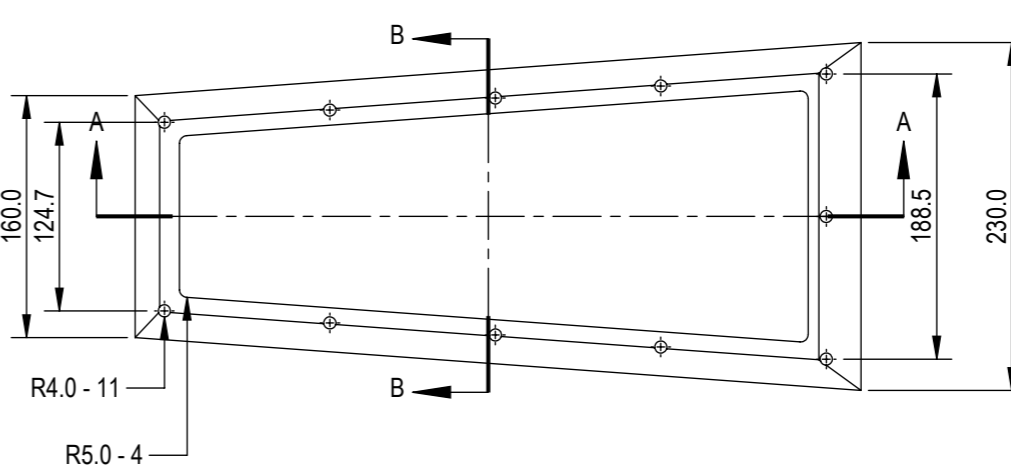
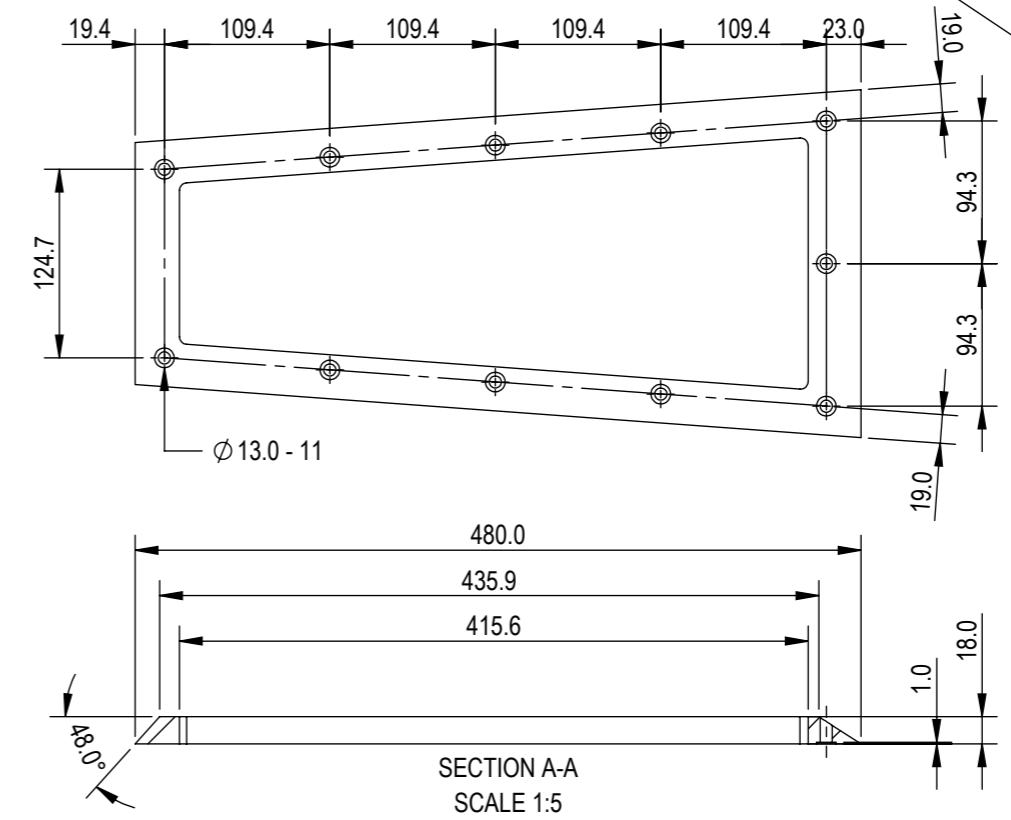

SECTION B-B
SCALE 1:5

BOARD ①

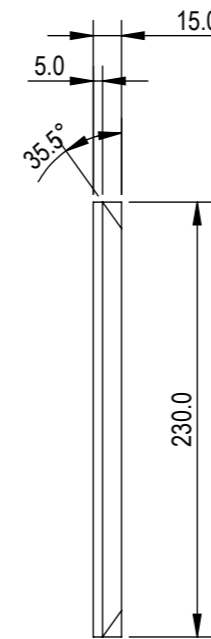
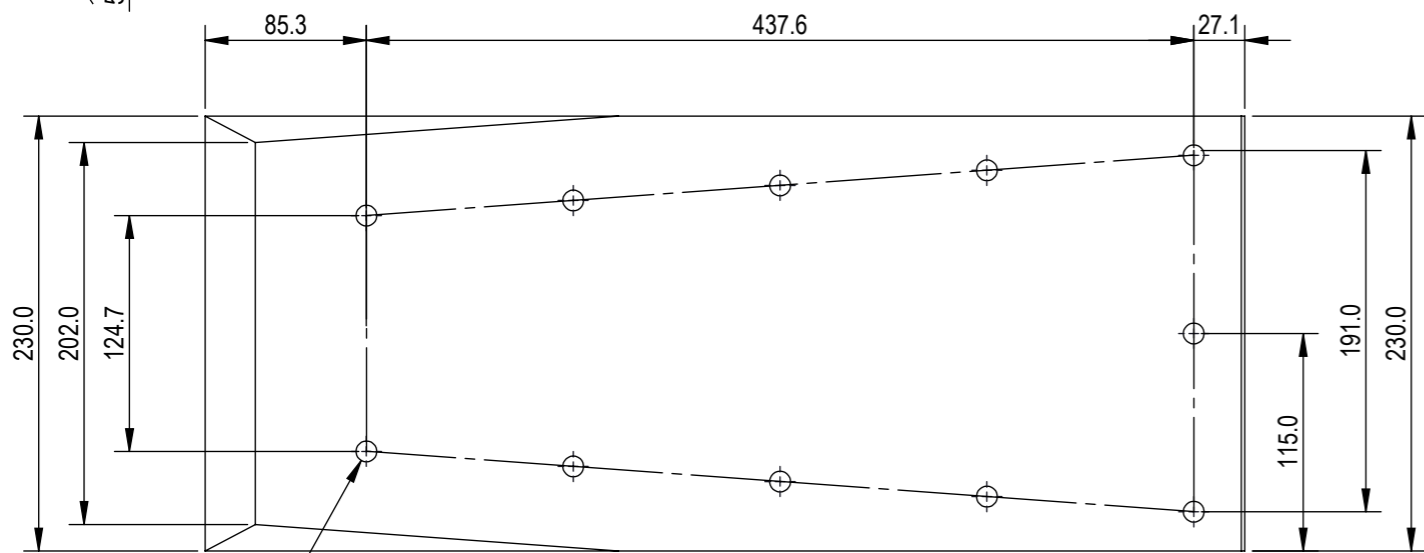
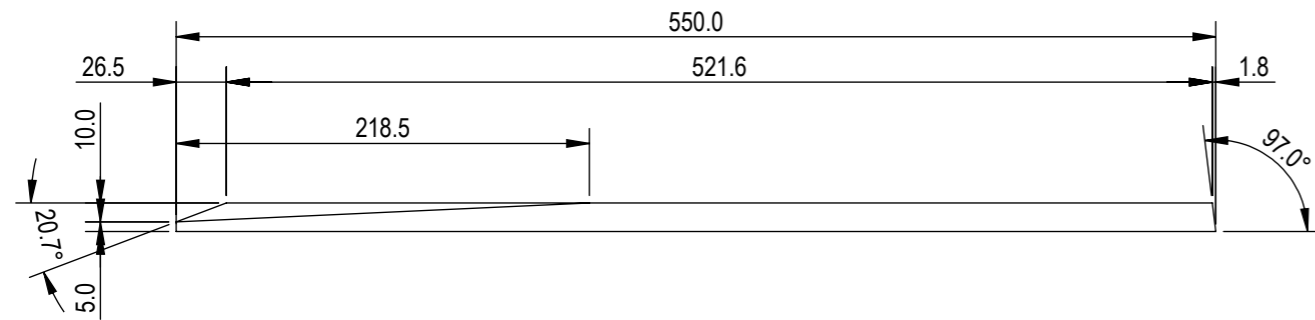
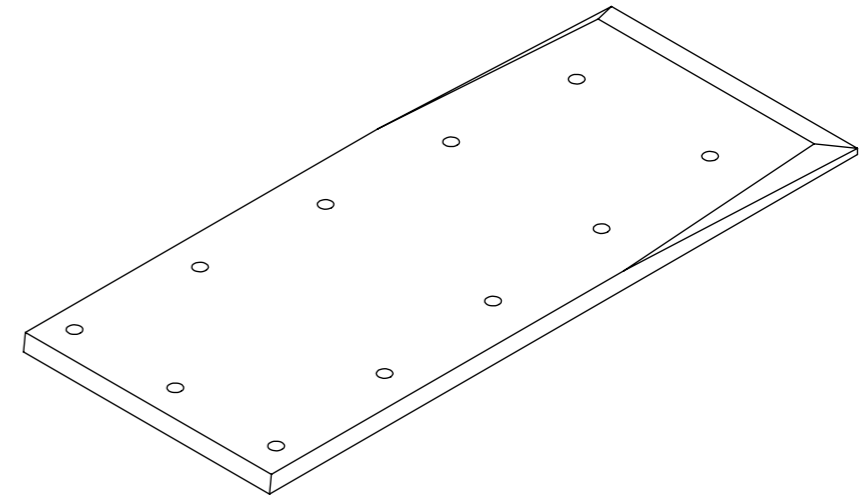
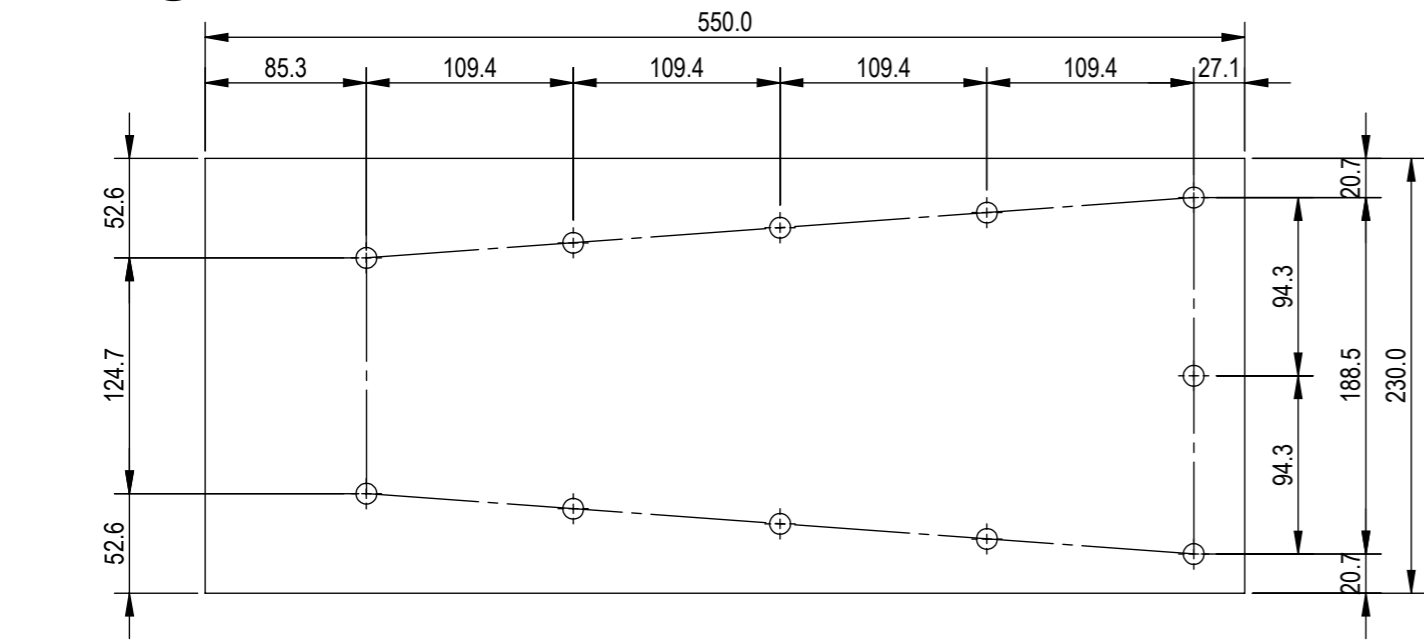

Ø 11.0 -11

NOTE:

- All dimensions are before painting except depth
- Depth dimensions after painting could be same with drawing
- There is no defect on painting
- Paint thickness assumed 0.5 mm

BOARD (J)

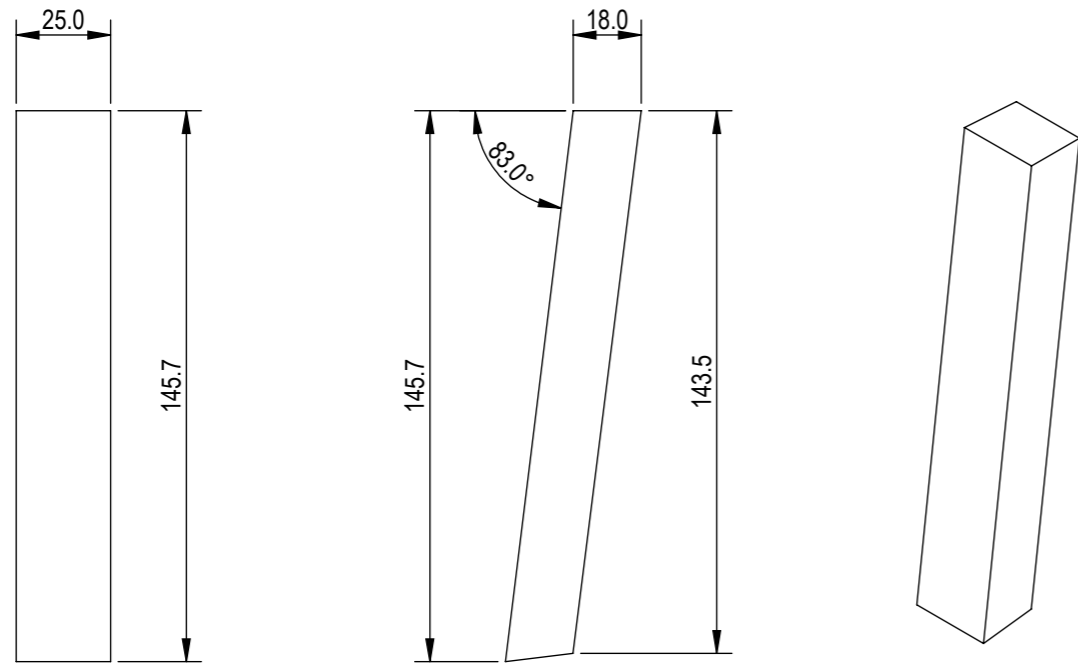

BOARD (L)

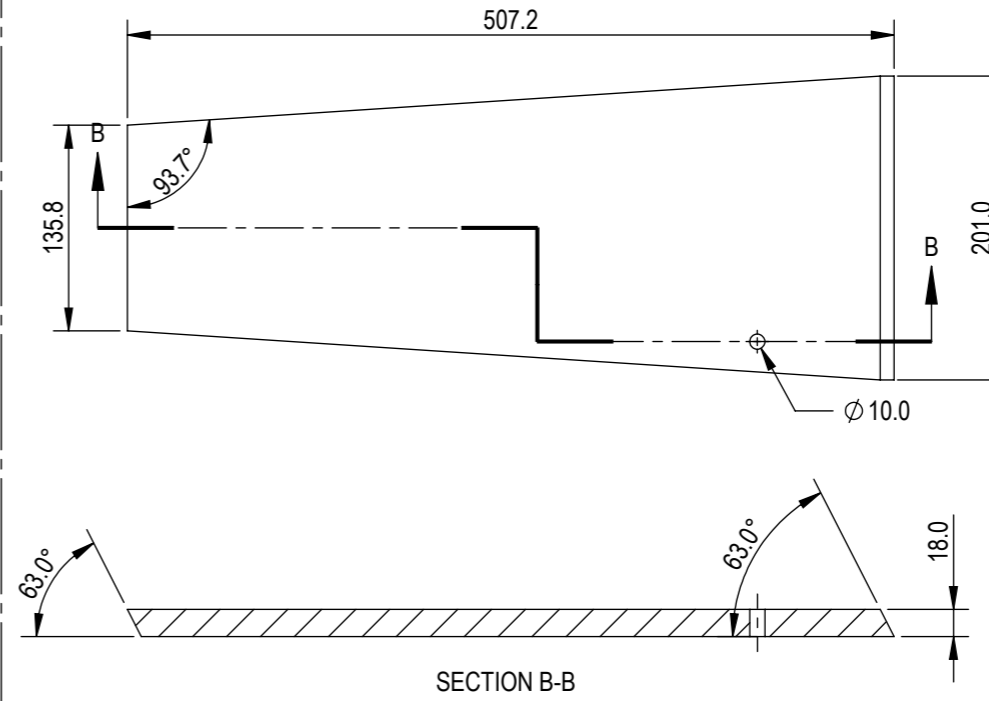

BOARD (K)

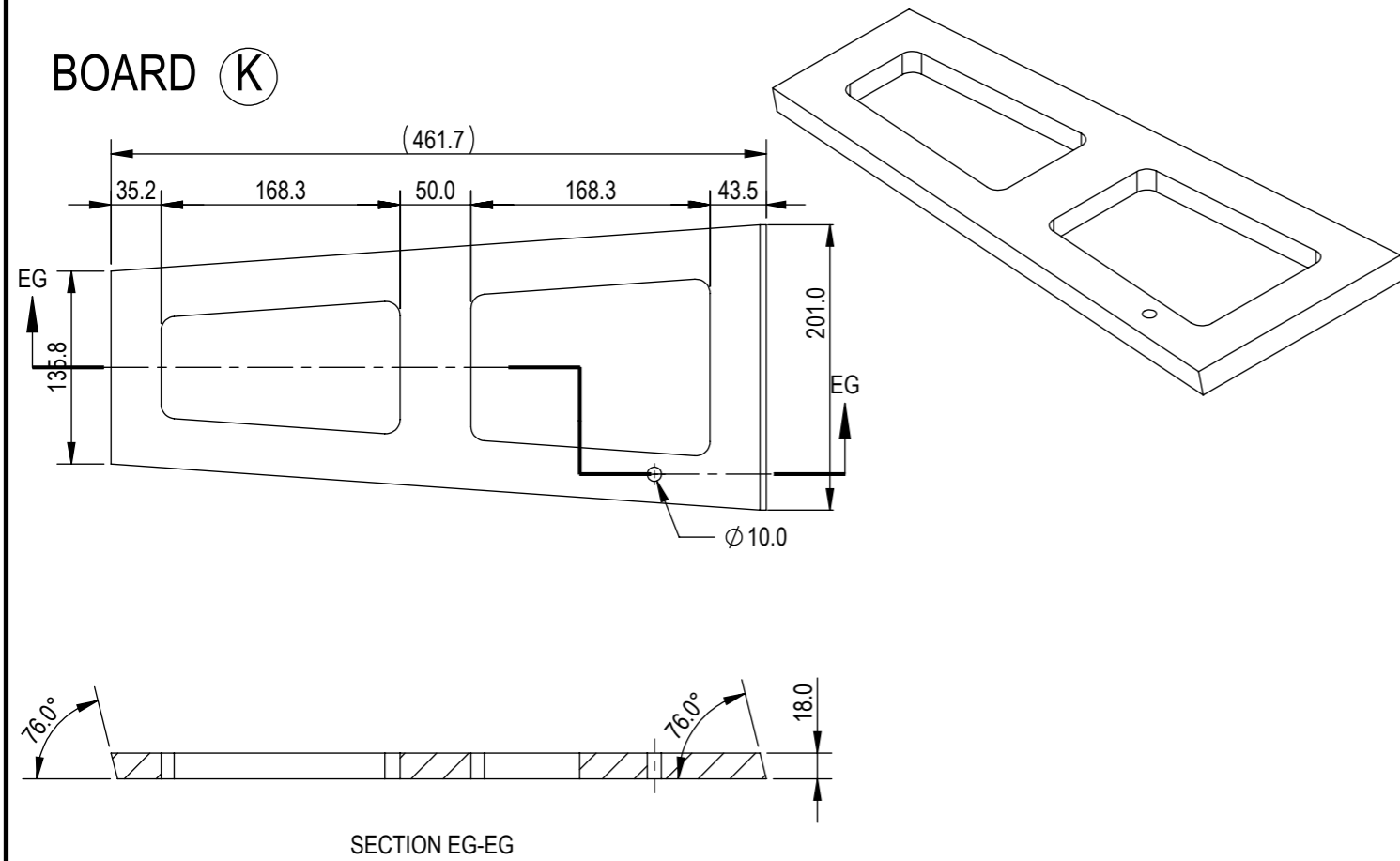

BOARD (M)

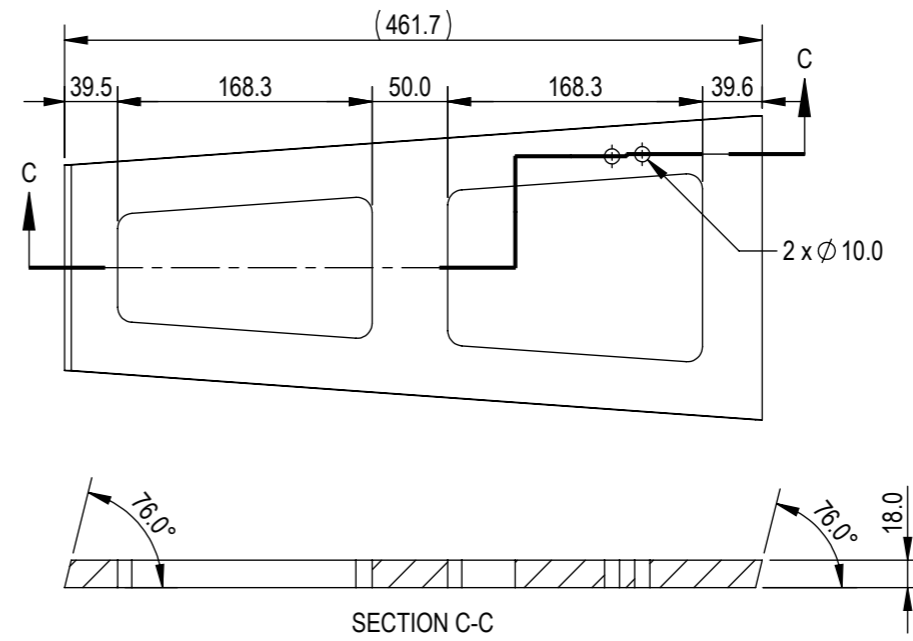

BOARD (N)

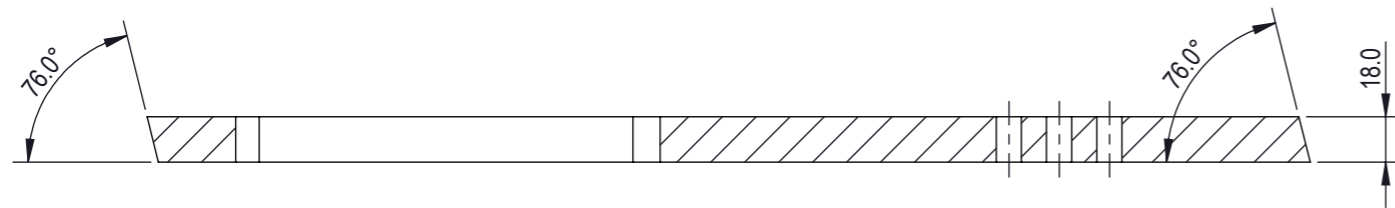
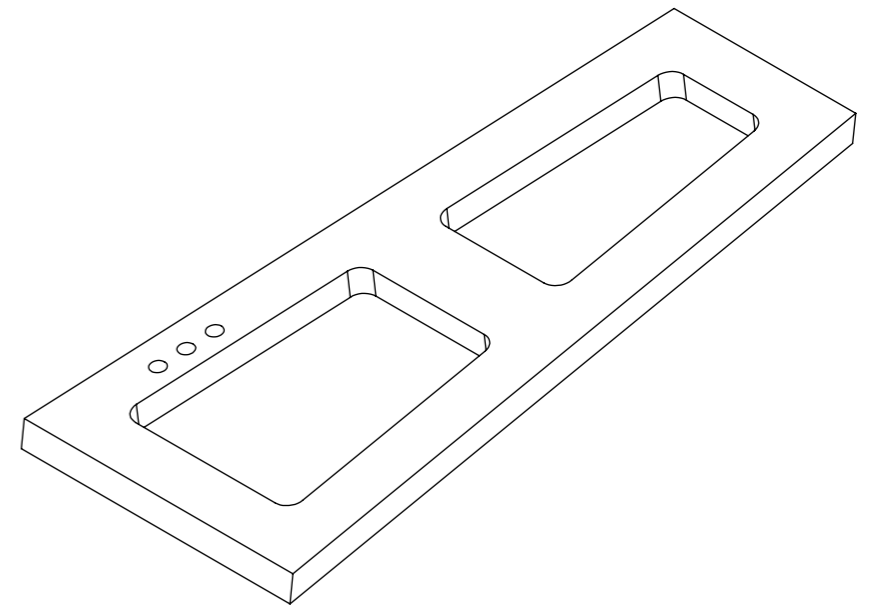
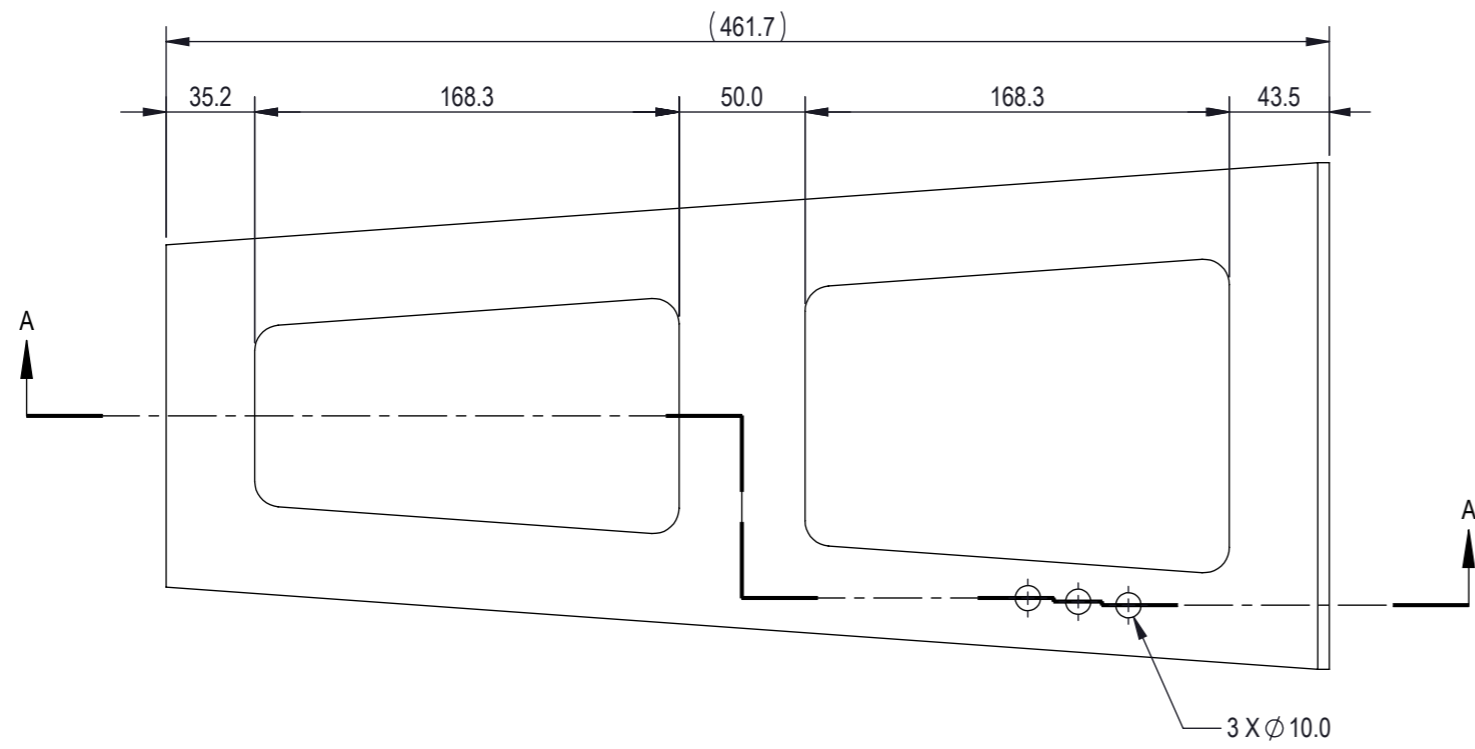

SECTION A-A
SCALE 1 : 3