

ROHS COMPLIANCE

DATE	DESCRIPTION	REV
11.05.13	NEW RELEASE	A

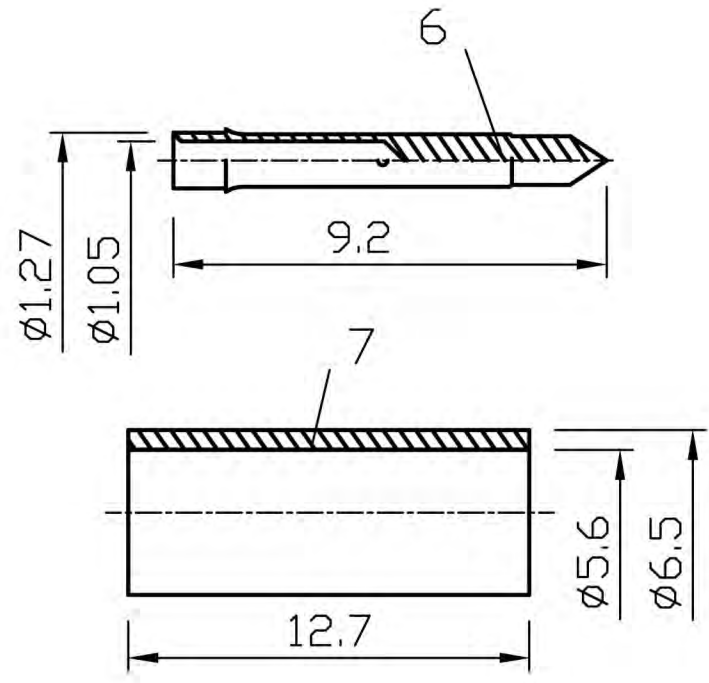
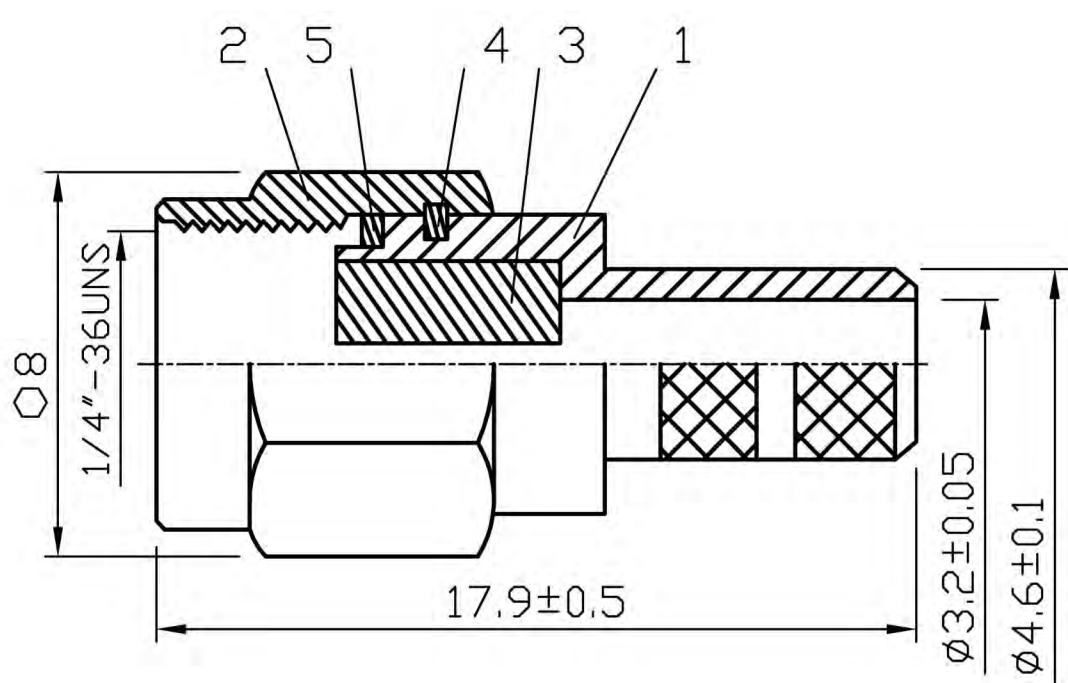

12					
11					
10					
9					
8					
7	RING	1	BRASS	GOLD	
6	PIN	1	BRASS	GOLD	
5	GASKET	1	RUBBER	RED	
4	WASHER	1	P.BRONZE	NONE	
3	INSULATOR	1	TEFLON	WHITE	
2	SHELL	1	BRASS	GOLD	
1	BODY	1	BRASS	GOLD	
NO	Description	Q'ty	Material	Finish	Part Number

UNLESS OTHERWISE SPECIFIED 1. REMOVE ALL BURRS. 2. BREAK ALL CONNERS & EDGES CO.15 MAX. 3. CHAMFER 1ST & LAST THREADS 45°. 4. DIAMETERS ON COMMON CENTERS. TO BE CONCENTRIC WITHIN 0.01 T.I.R. 5. ALL DIMENSIONS ARE AFTER PLATING.	MAJOR DIMENSIONS	APPROVED BY	DRAWING NO	
	UNLESS OTHERWISE NOTED TOLERANCES	CHECKED BY	SMA2808	
	0.5-6=±0.2 6-30=±0.4 30-120=±0.6 ANGLES=±5°	DRAWING BY	TITLE	REV.
	SCALE 4/1 UNIT MM	DATE 2011/05/13	SMA MALE CRIMP TYPE FOR RG58/U	A

DO NOT SCALE DRAWING