

12 Volt 10 Amp Switchmode Automatic Battery Charger

Operating Instructions

Please read these instructions before use

The GSL Battery Charger is a sophisticated 2 Mode Boost and Float Charge Type, utilising Switchmode technology and designed to charge 12 Volt Lead Acid Batteries. As a Lead Acid Battery Charger, the unit provides a safe method of restoring discharged batteries, via Boost and Float Mode circuitry.

Boost Mode – In this mode the battery charger delivers bulk charging current up to 10 Amps into the battery. When the battery voltage rises to approximately 13.8V, and the battery is 90% re-charged. The charger will switch automatically to Float Mode.

Float Mode – In this mode the battery charger output current is reduced to approximately 2A and the cooling fan is turned off. The battery is brought up to a 100% recharge and is constantly maintained at that level with the charger supplying just enough current to maintain the battery at full capacity.

Indicator Showing Battery Status :

Color	Condition
Red - Boost	The battery voltage is relatively low, the unit is charging at almost full output current and the fan is on.
Orange- Float	Battery charger in the float mode, charge current is below 2A and the fan is off.
Green - Power	Indicates that the AC power is within acceptable levels.

Installation & Safety Precautions:

1. This appliance is not meant for use by young children.
2. Young children should be supervised to ensure that they do not play with the appliance.
3. During charging process, do not use a naked flame near a battery, due to gases emitted from the battery, which may ignite and explode.
4. **Never smoke or light cigarettes near a battery**
5. Do not place tools on top of battery or allow tools to fall on battery.
6. Always wear eye protection near a charging battery.
7. Ensure a "well" ventilated area is used when testing or re-charging batteries.
8. Ensure ventilation is adequate and venting holes are not obstructed. Inadequate ventilation may over-heat the unit and cause inefficient operation.
9. The battery charger is intended for internal use only. Do not expose it to outdoor weather conditions e.g. rain or dampness.
10. If skin or clothing comes into contact with acid, flush the area(s) with water immediately. Seek medical attention if necessary.
11. The battery charger contains hazardous voltages. There are no user serviceable components inside. If the AC supply cord is damaged, in order to avoid a hazard it must be replaced by the manufacturer or its service agent or a similarly qualified person. **Should product require service, return it to place of purchase** .

Battery Charging Times:

The question of "how long will my battery take to re-charge" is always asked. Firstly, the charge rate (CR) of a battery is rated in Amps and the battery capacity (C) in Amp Hours. The battery manufacturer for each battery type normally states this CR. As a rule of thumb, a lead acid battery generally should be charged under 1/5 of C.

For example if you have a 50Ah battery, the recommended max. charging current is : $50 / 5 = 10A$.

The majority of the battery capacity would normally be charged in 5 hours using a 10 Amp battery charger.

Similarly it would take approximately 10 hours to charge a battery with a 5 Amp battery charger.

**Please note the figures quoted above could vary depending on the battery condition.*

12 Volt 10 Amp Switchmode Automatic Battery Charger

Operating Instructions
Please read these instructions before use

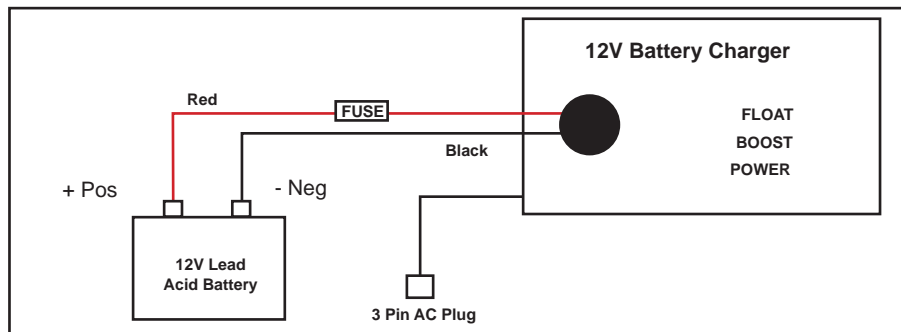

Procedures for Charging a Discharged Battery:

The charger is intended for 12V lead acid batteries with a capacity ranging from 10AH to 50AH. To avoid reverse polarity connection, the charger output leads are fitted with coloured battery clips for easy identification: **Red for (+) Positive pole and Black for (-) Negative pole.**

Prolonged output short circuit (above 20 seconds) or polarity reversal may require replacement of the output lead mounted 15A 12V output blade fuse.

1. Before connecting charger to battery, ensure that 240VAC power is switched off.
2. Disconnect all battery cables i.e. vehicle battery cables etc.
3. Remove cell caps from battery and check electrolyte levels in each cell with hydrometer. Ensure that electrolyte levels cover all plates in each cell completely.
4. Connect (+) positive and (-) negative clips to the respective battery terminals, ensuring a firm connection.
5. Connect battery charger to 240VAC power point and switch ON.
6. During the charging process the battery may be bubbling and emitting gases. This is quite normal.
7. When the battery is fully charged, switch 240VAC power OFF and remove the charger cables from the battery.

Specifications	
AC Input Voltage	180 - 250V
AC Frequency	50 Hz
AC Current (A)	1.3A max
Float Charging Voltage	14V
Output Current (A) approx. max.	10A @ 13V >Vo > 6V
Output impedance	0.04 Ohm @ Io<11A
Switching Frequency KHz	60KHz (typical)
Efficiency (Approx)	85%
Indicators	AC power, Boost and Float
Protection:	Overload, Over Voltage, Short Circuit Reverse Polarity (external fuse)
Approvals:	
Safety Standards No. N17018	AS/ANZ 60950:2000
C Tick No.N1408 (EMI, RFI)	AS/NZS2064 Group 1, Class A
Cooling	60 x 60mm Fan, load activated
Dimensions (mm)	233L x 115W x 70H
Weight	1.3Kg

Warranty Conditions: Our products come with guarantees that cannot be excluded under the Australian Consumer Law.

The customer is entitled to a replacement or refund for a major failure and compensation for any other reasonably foreseeable loss or damage. The customer is also entitled to have the products repaired or replaced if the products fail to be of acceptable quality and the failure does not amount to a major failure.

GSL Electronics (GSL) warrants that its products will, under normal use and service, be free of defects in material and workmanship for a period of two (2) years from the date of the original purchase by the customer as marked on the customer's original invoice. Please refer to our website for full warranty and return information which can be found at <http://www.gsl.com.au/faq.html>