

[INS250]

www.d-s-t.com.au

danish sound technology

HDS250-V2

CONSTRUCTION DETAILS

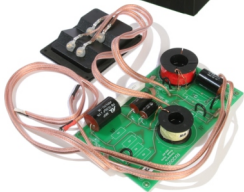

CHECK CONDITION OF ALL COMPONENTS BEFORE COMMENCING ASSEMBLY

CHECK THE CONTENTS OF THE KIT:

- Cabinet Assembled Complete.** All holes pre-drilled. Wadding material pre-attached to inside panels.
- Speaker Grill.** Assembled with cloth attached.
- Printed Circuit Board.** Fully assembled with all components & wiring to terminals & back-plate.
- Speaker. Mid-Bass Woofer 5"** Peerless 831882 (2pcs)
- Speaker. Tweeter Dome 1"** Peerless 810921 (1pcs)
- Set of Screws** for attaching drivers and terminal socket. (20pcs)
- Velcro Strips** for affixing the Circuit Board to the inside of the cabinet.



PREPARATIONS:

Take care as to not scratch the cabinet or puncture the drivers during assembly. Taking extra care would be well advised.

Place down a cloth or use the packaging box to work on. **Check all components** are present and in good condition. Contact place of purchase if any problem or transit damage. To assemble, you will require a **Philips head screwdriver**.

INSERT COMPONENTS:

- The Crossover Assembly** comprises of the Circuit Board and attached wiring.
- Set Crossover On-Board Links** - See the Crossover Setup on the next page. If unsure, the default is to leave all links on board as-is (connected).
- Attach Velcro strips** to the underside of the Circuit Board towards each end.
- Position the Cabinet** in it's normal upright position on a non-scratch surface.
- Feed the Rear-Panel Input Terminal** thru the front hole for the 5" Woofer, then thru to the felt and then rear hole so it is again, out side the box.
- Screw the Rear Panel Input Terminal** into place with the screws provided. Correct orientation is for the terminals to be pointing in the upward direction.
- Place the Cabinet** onto its back to continue with the crossover installation.
- Peel backing paper off the Velcro Strips** to expose the adhesive for use.
- Use a cloth** to ensure inside exposed surface is clean of dust & obstructions.
- Insert Circuit Board** into the box and affix firmly to the wall of the cabinet.
- Feed the speaker connection wires** out thru the appropriate speaker holes.
- Connect the Woofer** by attaching the wire pair with **RED & BLACK** plugs.
- Connect the Tweeter** by attaching the wire pair with **WHITE & BLACK** plugs.
- Make sure connections are firm & sturdy.** Use pliers may be of assistance.
- Insert the Drivers** with screws provided. You will find pre-drilled pilot holes.
- Be Careful!** Not to slip with the screwdriver and puncture the speaker cone.
- You are done!** Attach speaker grill and proceed to speaker setup *next page...*

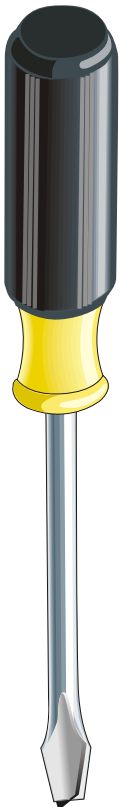

HDS250-V2

Page-2: Information.

CROSSOVER SETUP: *Do I Cut Any Links?*

- NO!** In the default set-up there is no need to alter the crossover in any way. *Proceed with the installation...* These Links ensure correct and secure connection of BOTH drivers to the amp incase the SHORTING STRAPS become loose or are accidentally removed and/or lost.
- BI-WIRE INSTALLATION.** Some audiophiles may wish to take advantage of this option. If you intend to Bi-Wire the speakers to the amplifier, remove the rear input terminals' **SHORTING STRAPS** and **CUT both LINK-1 and LINK-2.** **NOTE! DO NOT REMOVE LINK 3, DOUBLE-CHECK THIS.**

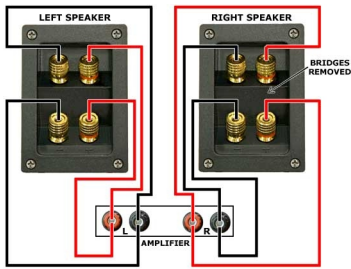
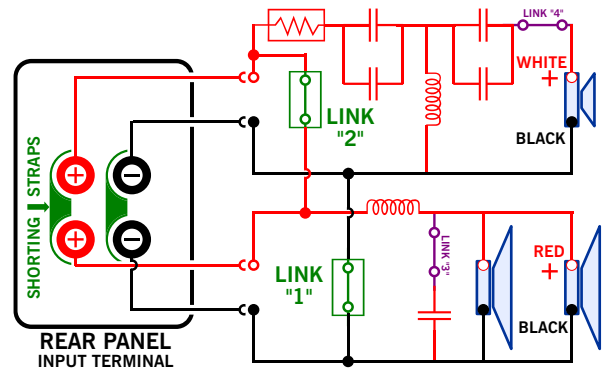

Bi-Wire Connection

What Is Bi-Wiring and should I bother?

- The term Bi-Wire simply refers to the fact that you will be running two sets of loudspeaker cables from your amplifier to each of your speakers. Both the high and low circuits are now entirely separate all the way back to the amplifier.
- The idea with Bi-Wiring is to give a more direct path of each driver & filter circuit to the amplifier. This takes advantage of an amplifiers high damping factor thus reducing unwanted intermodulation distortion between the mid-woofer & tweeter.
- Some will argue that there is little to no advantage for the additional cabling cost. Positive results may also depend on the quality of the amplifier and cable used.

SPECIFICATIONS:

- FREQUENCY RANGE** 47Hz - 25KHz (On-Axis)
47Hz - 20KHz (+/- 30° Off Axis)
- EFFICIENCY MEASURED** 91.5dB (SPL @ 1M 2.83Vrms)
- NOMINAL IMPEDANCE** 4 ohms (3.6 ohms @ DC Minimum)
- RECOMMENDED AMP** 5 to 150W *Unclipped Program Material*
- MID-WOOFERS** Peerless x2 831882 Peerless 5" Phase Plugged
- TWEETER** Peerless x1 810921 HDS Soft-Dome 1"
- CROSSOVER** 3.3KHz, LP[12dB], HP[18dB]
Bessel / Butterworth, Linear Phase
- SIZE** 595x180x305mm 15Kg

NB:

- Speakers are NOT Shielded. Unsuitable for use near CRT.

The Peerless HDS tweeter is Time-Alligned (physically counter-sunk into the box) and Phase-aligned in an MTM coaxial design with a premium quality, professionally tuned box for incredible clarity, definition, accuracy and fantastic dynamic impact that rivals any speaker in this sized package. A true audiophile speaker for music & home theater. Exclusive to WES. Design by Russell Storey of Stones Sound Studio.

