

General Specification

Type	HST-660-2YCT
Frequency Response	55~20kHz
Sensitivity	88 dB
Power Handling	60 W
Power taps	30W/15W/7.5W
Line input	100V/8Ω
Dimension(L*W*H)	240*167mm
Cut-out diameter	203mm

Physical Specification

Material	ABS
Component	6,5"
Grille	Metal
Finished Colour	White

Speaker Specification

DC Impedance	7.2Ω
Magnet	Ferrite φ100*φ45*15mm

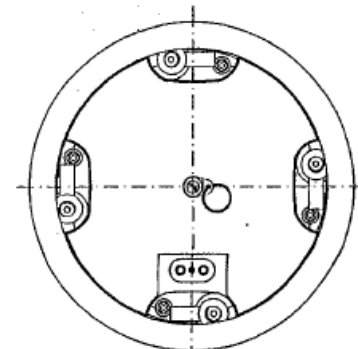
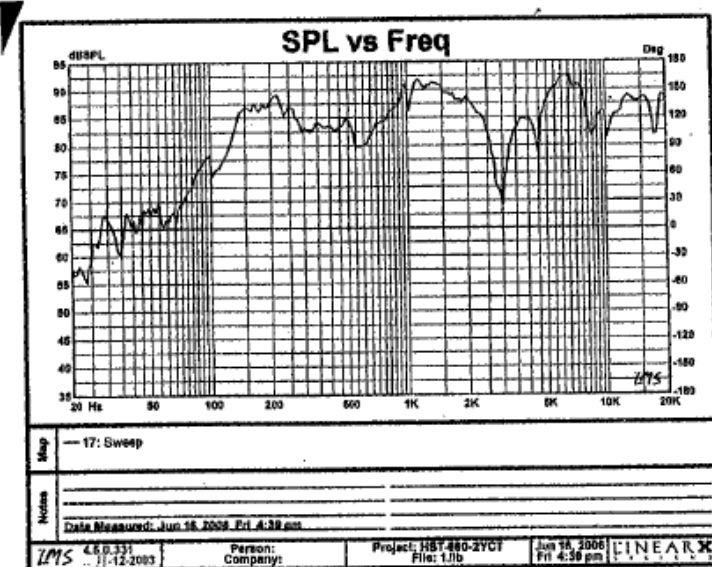
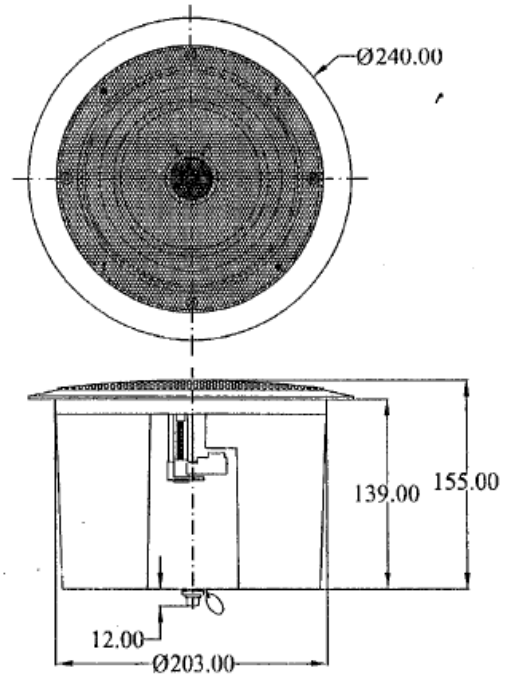
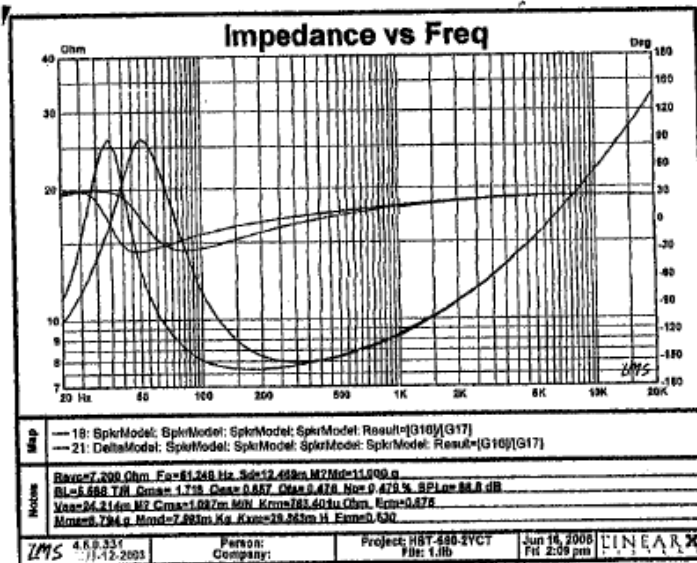

宏泰順電子（深圳）有限公司

HIGH HIT ENTERPRISE CO.LTD

產品規格書（SPECIFICATIONS）

客 戶 (CUSTOMER)		口 徑(SIZE)		6-1/2"	
客戶型名(CUSTOMER'S NO)		樣品型号(SAMPLE NO)		ADS1660	
編號	項 目	規 格 及 測 定 條 件			
1	標稱阻抗 (IMP)	ACR:8.0Ω ±15% AT300HZ 1.0 V			
2	直流阻抗 (DCR)	DCR:7.2Ω ±7%			
3	動作 (OPERATION)	Must be normal At program source30W			
4	異常音 (BUZZ AND RATTLE)	Must be normal Sine wave13.0V at Fo-20KHz			
5	最低共振頻率 (RESONANT FREQ (F ₀))	喇叭 Fo: 46 ± 20 % Hz 裝箱后 Fo: 131 ± 20 % Hz Without baffle			
6	出力音壓 (S.P.L)	Mean value at88±2dB 300 400 600 800 4K 6K 8K 10 KHz average; At 1W on axis calculated from 1.0M/2.83measurement			
7	實效頻率範圍 (FREQ RESPONSE)	Fo~20KHz			
8	額定頻率範圍 (RATED POWER INPUT)	Fo~20KHz Max deviation-10dB			
9	額定輸入功率 (RATED POWER INPUT)	60W (BOX Ass'y 状态)			
10	最大輸入功率 (P.M.P.O.)	120W			
11	失真率 (DISTORTION)	5% MAX			
12	耐寒試驗 (COLD TEST)	-25±3℃ 16H			
13	耐熱試驗 (HEAT TEST)	70±2℃ 16H			
14	耐濕性(周期性) (COMPOSITE TEMPERATURE/HUMIDITY CYCLC TEST)	濕度: 溫度: 時間:			
15	磁束密度 (FLUX DENSITY)	±10%Gauss			
16	總磁束 (TOTAL FLUX)	MAXWEL			
17	磁鐵 (MAGNET)	主磁Φ100*Φ45*15mm () Material(Ferrite) OZ 副磁Φ*Φ*mm () Material			
18	重量 (WEIGHT)	G			
19	絕緣抵抗 (INSULATION)	喇叭端子與露出金屬部分之間有 2MΩ 500V 以上 More than 2MΩ between a terminal & a bare metal section of SPK			
20	極性 (POLARITY)	喇叭端子(+)側連接正電流時,振動板要往 前 方向振動 THE CONE SHALL MOVE FORWARD THE MAGNET			
21	連續負荷試驗 (LOAD TEST)	<input type="checkbox"/> WHITE NOISE 96H <input type="checkbox"/> SN-1 IEC268 8H <input type="checkbox"/> PINK NOISE 8H <input type="checkbox"/> 426A 16H <input type="checkbox"/> IEEE 219 8H			
22	漏磁密度 (FLUX LEAKAGE)	距離後蓋 mm 漏磁束≤ G			
23	中音 (MODRANGE)				
24	高音 (TWEETER)	20MM 蚕丝+钛 DOME TWEETER +分音器			
25	變壓器 (TRANSFORMER)	100V, 30W/15W/7.5W-8Ω			
擔 當		照 查		承 認	核 准

宏泰顺电子（深圳）有限公司

文件编号

备注

图名

成品图

型号

ADS1660

发

日期

2011.05.11

规格

图

版本

A0

图号

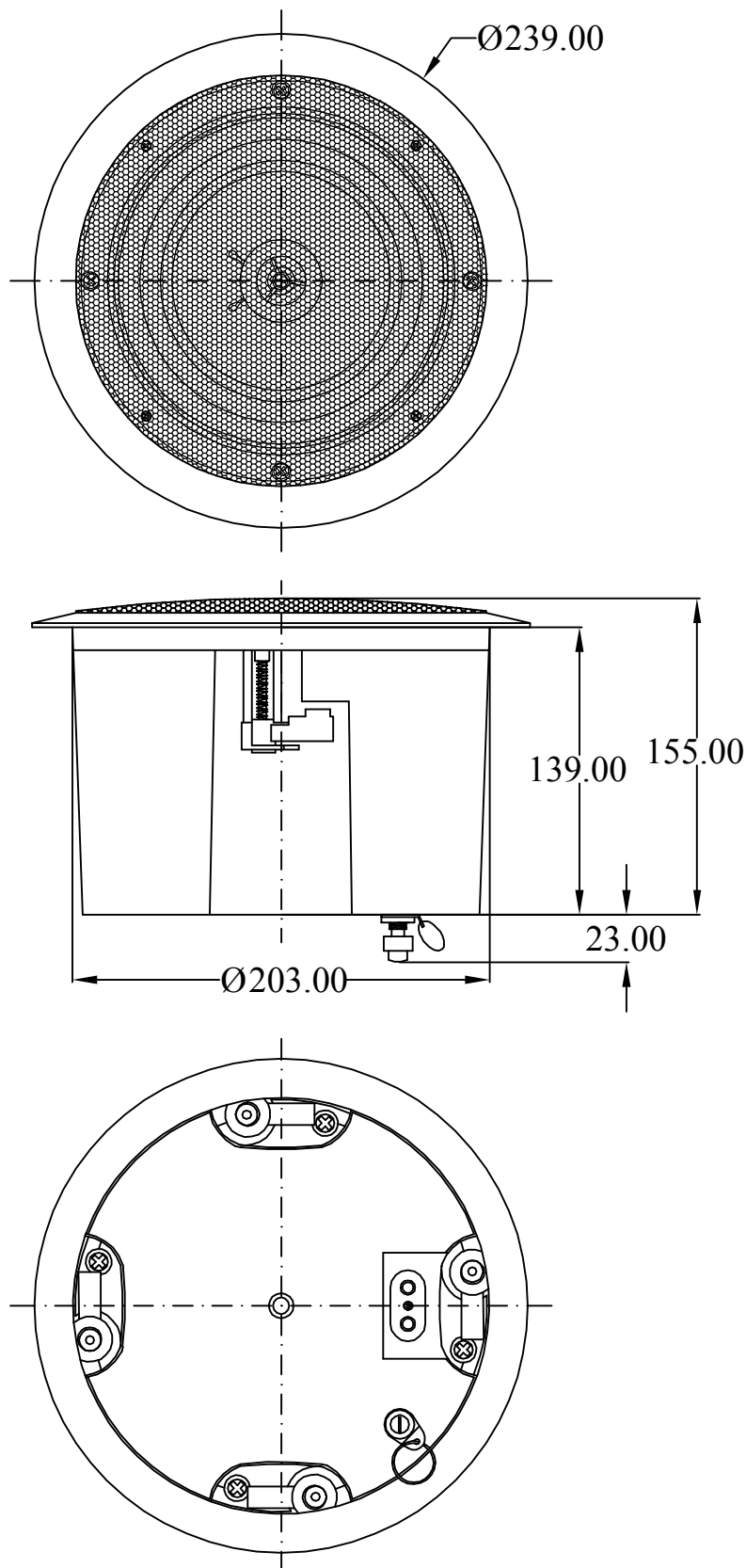

材料

制

担

照

承

核

比例

单位/mm一般公差

图

当

查

认

准