

## D1075T

## 75W Driver with 70V Transformer



The Dayton Audio D1075T PA driver provides efficient, articulate sound and is designed to excel in the harshest environment. The phenolic-impregnated cloth diaphragm will resist years of continuous stress, and multiple-attenuation taps on the enclosed transformer permit easy adjustment of maximum output.

### Features

- High power handling
- Durable phenolic diaphragm
- Weather-tight housing
- High output, low distortion
- Integrated 70V transformer with selectable taps
- 1-3/8"-18 threaded horn coupling
- Five-year warranty

### Parameters

Nominal Input (V)	70.7
RMS Power Handling (W)	75
Frequency Response* (Hz)	180 - 6,000
Horn Coupling	1-3/8" - 18 x 1/2"
Impedance (Ω)	16
SPL (dB@1W/1m)	110
Weatherproof	Yes
Explosion Proof	No
Voice Coil Material	Kapton / Copper
Voice Coil Diameter (Inches)	2
Weight (kg)	2.5
Transformer Taps (W)	25, 30, 50, 75, 16 Ω

**Warning:** This product not suitable for locations requiring explosion-proof electrical hardware.

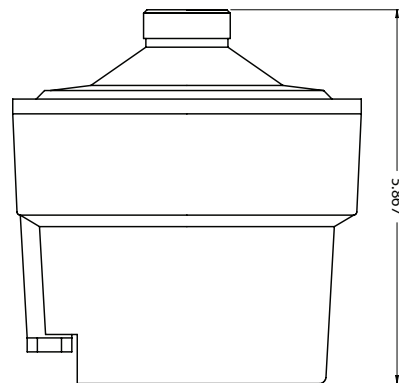
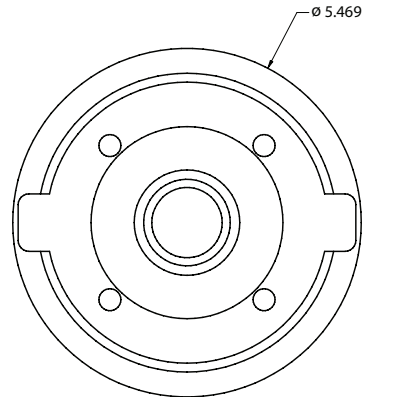

Note: All dimensions in inches.

### Frequency Response

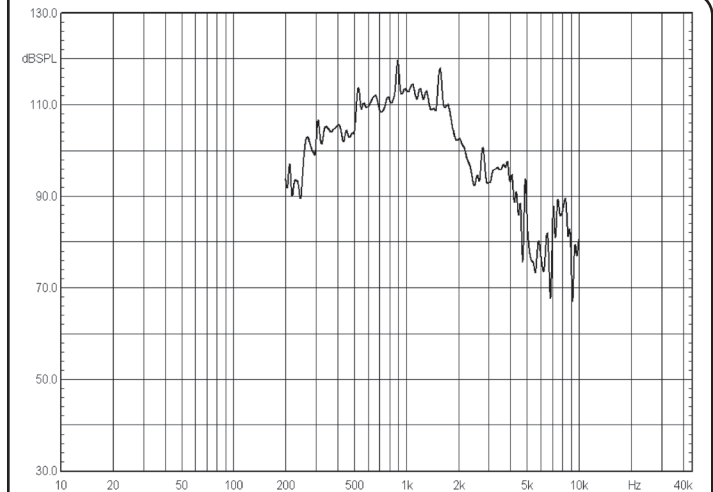

Frequency Response measured on RPH20 Horn @ 16-ohm tap, 5.6Vrms (1W)

### Impedance/Phase

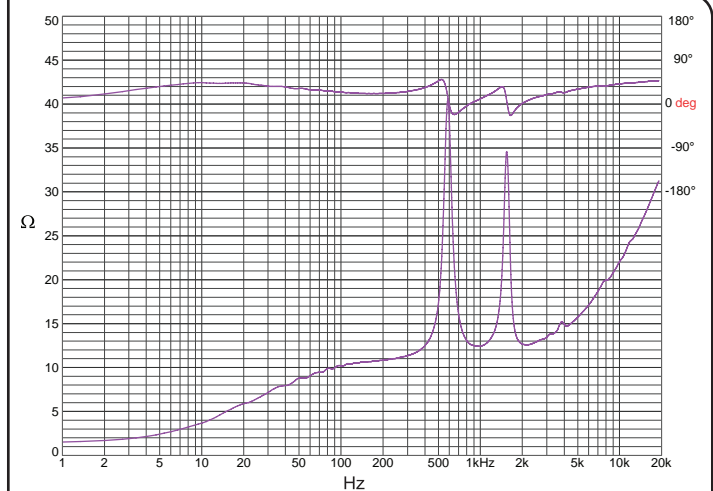

Impedance Response measured without horn