

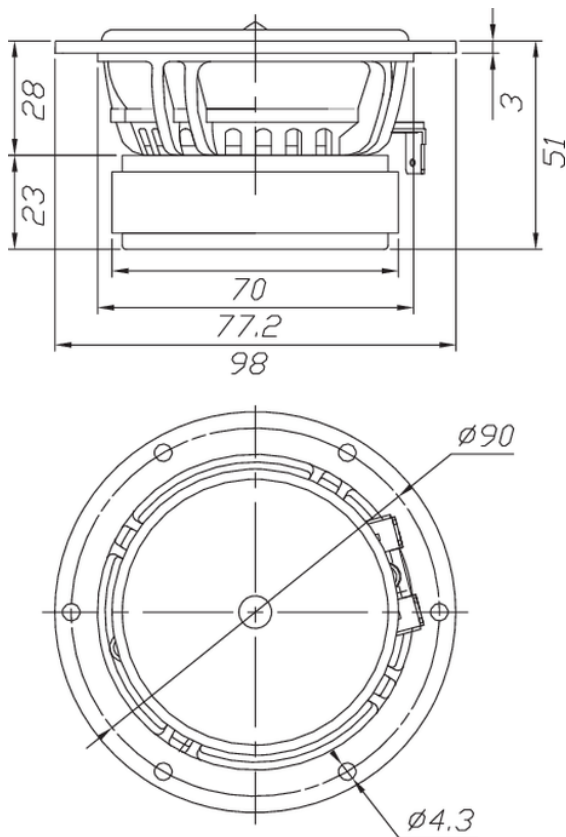

# RS100P-8 4" Reference Paper Midwoofer 8 Ohm

RS100P-8



## PARAMETERS

Impedance	8 ohms
Re	6.6 ohms
Le	0.51 mH @ 1 kHz
Fs	95.6 Hz
Qms	2.18
Qes	0.71
Qts	0.54
Mms	2.8g
Cms	0.98 mm/N
Sd	37.4 cm <sup>2</sup>
Vd	13.8 cm <sup>3</sup>
BL	3.95 Tm
Vas	1.82 liters
Xmax	3.7 mm
VC Diameter	25 mm
SPL	86.2 dB @ 2.83V/1m
RMS Power Handling	30 watts
Usable Frequency Range (Hz)	90 - 12,500 Hz

## FEATURES

- Three-part paper composite diaphragm featuring paper, Kevlar, and glass fibers
- Similar cosmetics and design features as original Reference Series with low-distortion
- Perfect for use a woofer, midwoofer, or dedicated midrange driver

## IMPEDANCE/PHASE

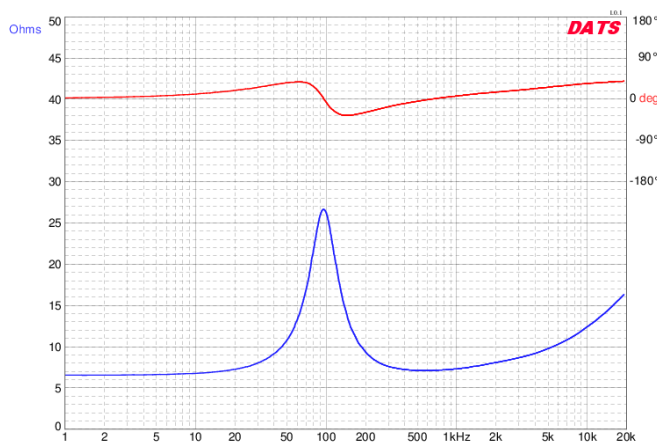

## FREQUENCY RESPONSE

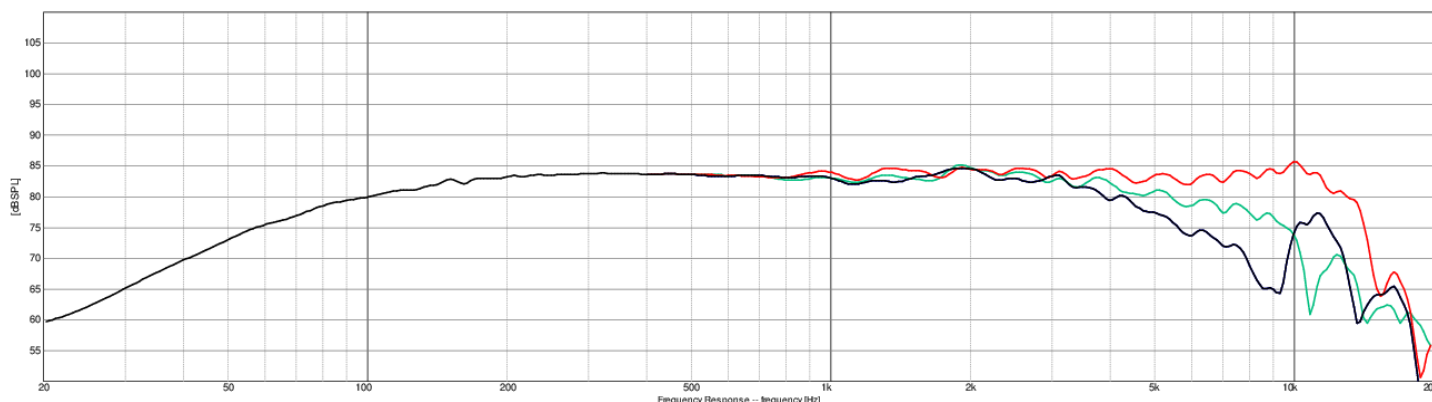

Note: 1/24<sup>th</sup> octave smoothing - nearfield response included in graph below 450 Hz.

Black = 0°  
Red = 15°  
Green = 30°  
Blue = 45°