

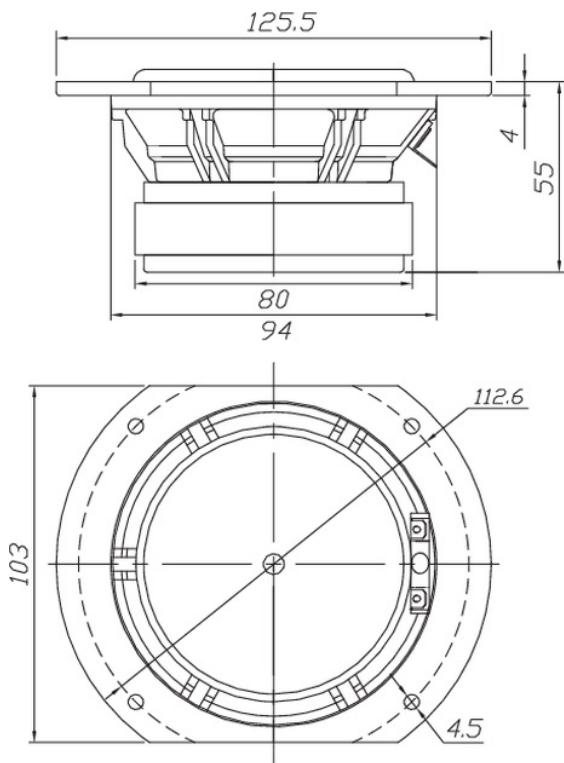

RS125T-8 5" Reference Woofer Truncated Frame 8 Ohm

RS125T-8



PARAMETERS

Impedance	8 ohms
Re	6.4 ohms
Le	0.58 mH @ 1 kHz
Fs	76 Hz
Qms	2.62
Qes	0.61
Qts	0.50
Mms	5.1g
Cms	0.87 mm/N
Sd	54.1 cm ²
Vd	15.1 cm ³
BL	5.04 Tm
Vas	3.56 liters
Xmax	2.8 mm
VC Diameter	25 mm
SPL	86.9 dB @ 2.83V/1m
RMS Power Handling	30 watts
Usable Frequency Range (Hz)	75 - 9,200 Hz

FEATURES

- Truncated cast frame, great for line arrays and MTM speaker designs
- Long-excursion motor and suspension for strong bass performance
- Advanced low-distortion motor design
- Distortion-reducing copper ring in magnetic gap
- Lightweight black anodized aluminum cone

IMPEDANCE/PHASE

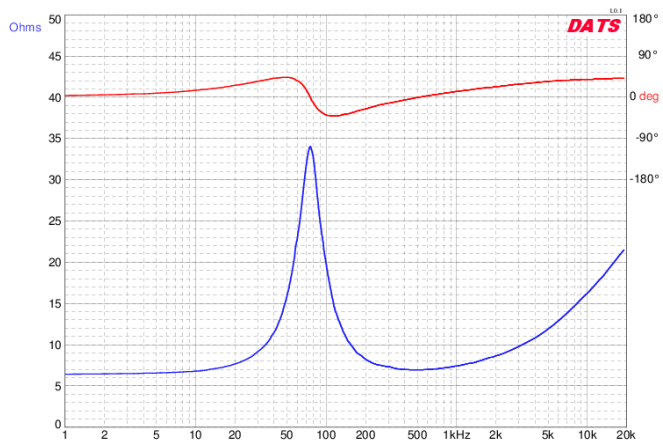

FREQUENCY RESPONSE

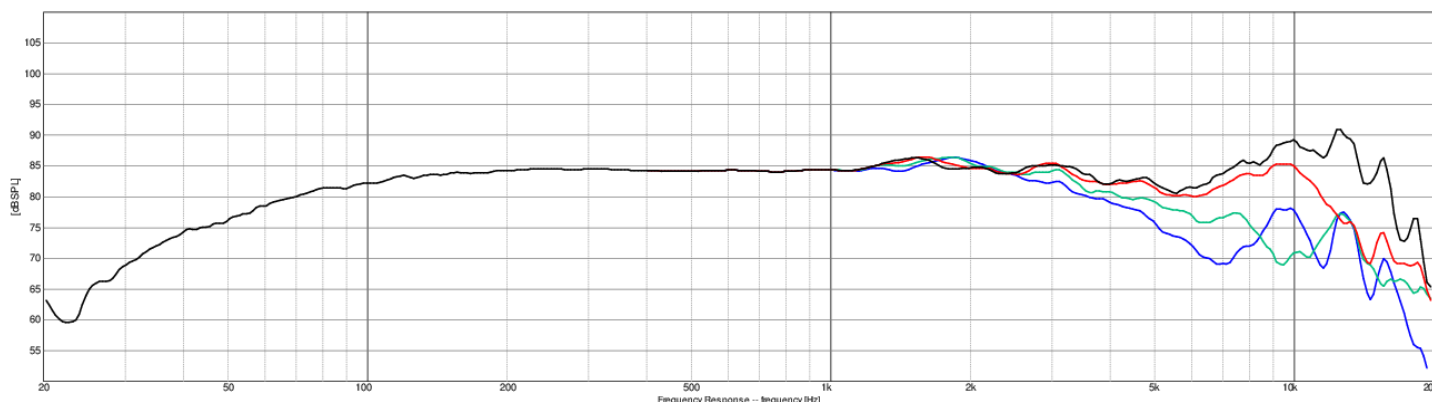

Note: 1/24th octave smoothing - nearfield response included in graph below 450 Hz.

Black = 0°
Red = 15°
Green = 30°
Blue = 45°