

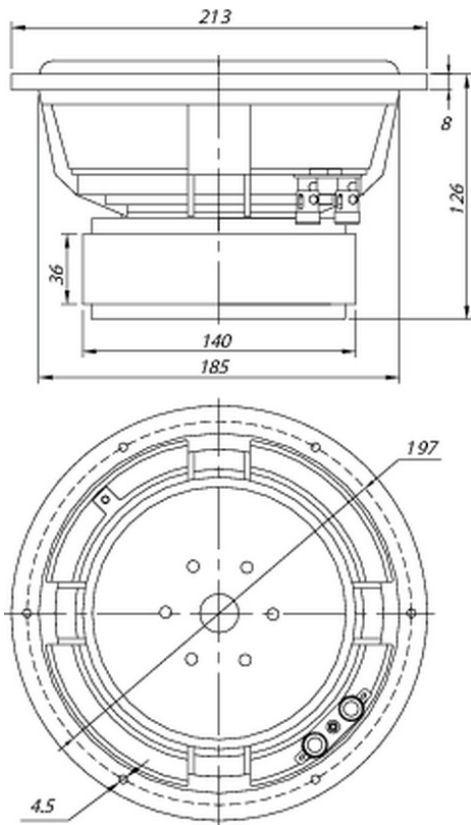

# RSS210HO-8 8" Reference HO Subwoofer 8 Ohm

RSS210HO-8



## PARAMETERS

Impedance	8 ohms
Re	5.9 ohms
Le	1.46 mH @ 1 kHz
Fs	29.6 Hz
Qms	2.78
Qes	0.45
Qts	0.39
Mms	99.3g
Cms	0.29 mm/N
Sd	N/A
Vd	256.6 cm <sup>3</sup>
BL	15.6 Tm
Vas	18.7 liters
Xmax	12 mm
VC Diameter	50 mm
SPL	83.5 dB @ 2.83V/1m
RMS Power Handling	300 watts
Usable Frequency Range (Hz)	30 - 1,500 Hz

## FEATURES

- Extensively vented motor eliminates power compression and allows quiet excursion
- Triple shorting-ring motor for ultra-low distortion
- Heavy-gauge aluminum cones withstand pressures of small enclosures
- 4-layer high-temperature coils for maximum power handling
- Durable aramid fiber spider for greater mechanical control

## IMPEDANCE/PHASE

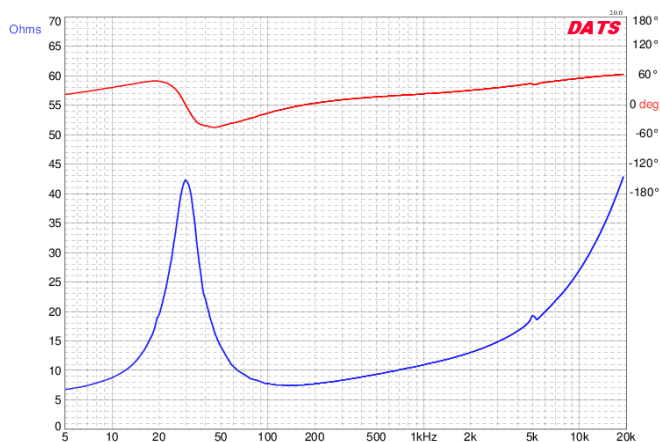

## FREQUENCY RESPONSE

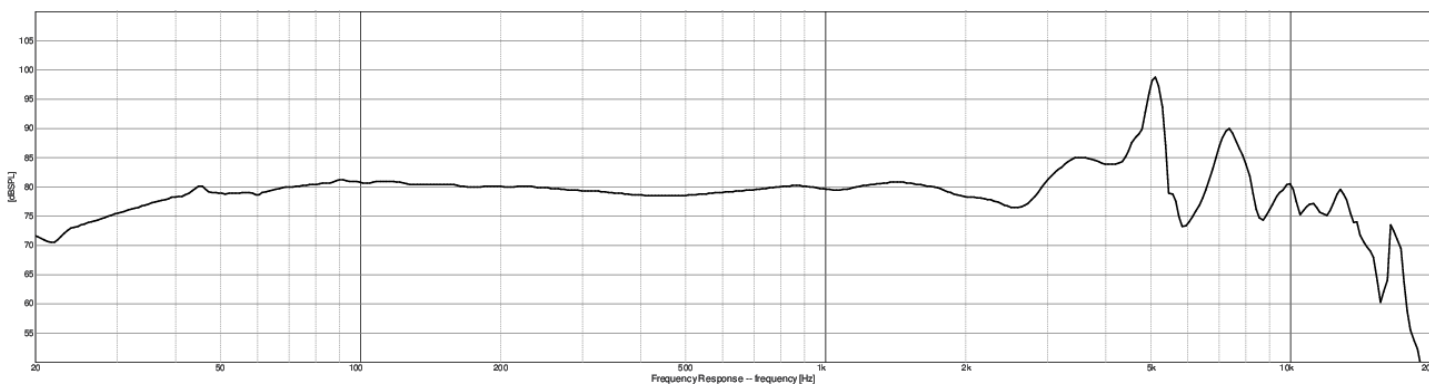

Note: 1/24<sup>th</sup> octave smoothing - nearfield response included in graph below 450 Hz.

Black = 0°