

Model Number: P830990  
 Description: Peerless HDS 6.5" GFP cone

Revision: rev 2\_0  
 Date: 1-Sep-09



The new Peerless HDS product line continues the tradition of Peerless' High Definition Sound (HDS) products. A powerful ferrite magnet system is coupled to a finite element analysis designed suspension system, containing both a linear spider design and a rubber surround. The motor contains an aluminium shorting ring, which reduces coil inductance, thus providing both extended frequency response performance and reduced distortion. The long-throw voice coil ensures linear high excursion performance, needed for signal clarity. The cone necks are vented so as to reduce air compression effects under high excursion conditions. The cast aluminium basket offers structural rigidity, heat sinking capacity for the motor, and additional air venting under the spider so as to again reduce air compression effects. The cone in this model is glass-fibre composite (GFP) offering a unique visual and acoustic experience.



**Mechanical 2D Drawing:**

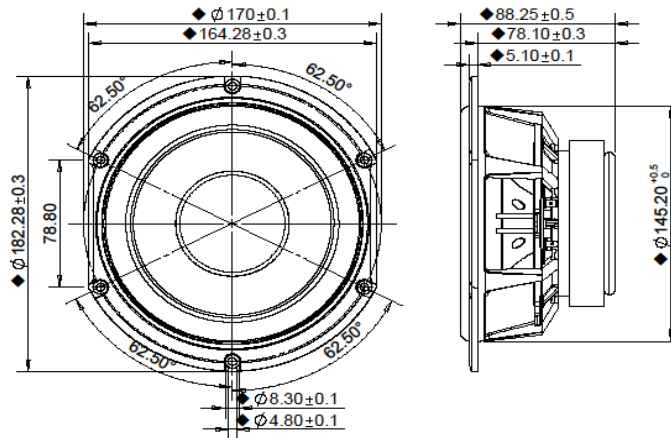

**Specifications:**

DC Resistance	$R_{vc}$	$\Omega$	6.2	Energy Bandwidth Product	EBP	$(1/Q_{es})f_s$	104
Minimum Impedance	$Z_{min}$	$\Omega$	6.9	Moving Mass	$M_{ms}$	g	16.97
Voice Coil Inductance	$L_e$	mH	0.42	Suspension Compliance	$C_{ms}$	um/N	698.2
Resonant Frequency	$f_s$	Hz	46	Effective Cone Diameter	D	cm	13.5
Mechanical Q Factor	$Q_{ms}$	-	3.1	Effective Piston Area	$S_p$	cm <sup>2</sup>	143.1
Electrical Q Factor	$Q_{es}$	-	0.44	Equivalent Volume	$V_{as}$	L	20.09
Total Q Factor	$Q_{ts}$	-	0.39	Motor Force Factor	BL	T-m	8.32
Ratio $f_s / Q_{es}$	F	$f_s / Q_{es}$	119	Motor Efficiency Factor	$\beta$	$(T-m^2)/\Omega$	11.12
Half Space Sensitivity @ 2.83V	dB@2.83V/1m	dB	88.4	Voice Coil Former Material	$VC_{fm}$	-	ASV
Rated Noise Power (IEC 2685 18.1)	P	W	50	Voice Coil Inner Diameter	$VC_d$	mm	32.4
Test Spectrum Bandwidth	20Hz - 3000Hz	12 dB/Oct		Maximum Linear Excursion	$X_{max}$	mm	5.34
				Transducer Mass	-	kg	1.582

**Frequency and Impedance Response:**

