

Model Number: HDS-P835024
Product Line: Peerless Gold

Revision: Rev 3
Date: 24-Oct-14



Product Description:

This 5.25 inch 8 ohm driver is a member of the high performance HDS family. A powerful ferrite magnet system is coupled to a finite element analysis designed suspension system, containing both a linear spider design and a rubber surround. The motor contains an aluminium shorting ring, which reduces coil inductance, thus providing both extended frequency response performance and reduced distortion. The long-throw voice coil ensures linear high excursion performance, needed for signal clarity. The cone necks are vented so as to reduce air compression effects under high excursion conditions. The cast aluminium basket offers structural rigidity, heat sinking capacity for the motor, and additional air venting under the spider so as to again reduce air compression effects. The cone in this model is aluminium, offering a unique visual and acoustic experience.



Mechanical 2D Drawing:

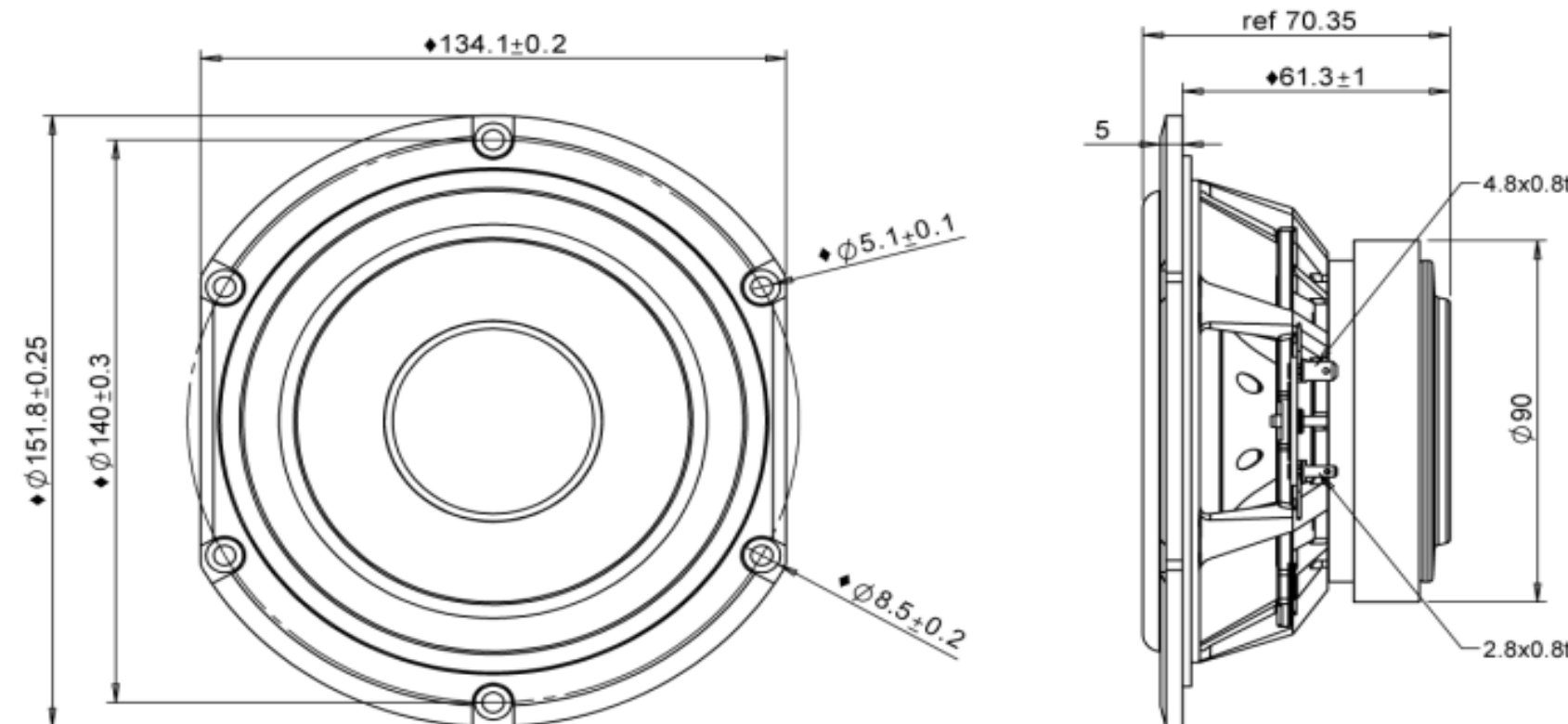

Specifications:

DC Resistance	R_{ewc}	Ω	5.9	5.0%	Energy Bandwidth Product	EBP	$(1/Q_{\text{es}}) \cdot f_s$	87
Minimum Impedance	Z_{min}	Ω	6.2	7.5%	Moving Mass	M_{ms}	g	10.6
Voice Coil Inductance	L_e	mH	0.24		Suspension Compliance	C_{ms}	um/N	457
Resonant Frequency	f_s	Hz	72	15.0%	Effective Cone Diameter	D	cm	10.80
Mechanical Q Factor	Q_{ms}	-	3.18		Effective Piston Area	S_D	cm ²	91.6
Electrical Q Factor	Q_{es}	-	0.82		Equivalent Volume	V_{as}	L	5.392
Total Q Factor	Q_{ts}	-	0.65		Motor Force Factor	BL	T·m	5.88
Ratio f_s / Q_{ts}	F	f_s / Q_{ts}	110		Motor Efficiency Factor	β	$(\text{T} \cdot \text{m}^2) / \Omega$	5.84
Half Space Sensitivity @ 2.83V	dB@2.83V/1m	dB	86.1	+/-1.0 ¹	Voice Coil Former Material	VC _{fm}	-	ASV
Sensitivity @ 1W/1m	1W/1m	dB	84.8	+/-1.0 ¹	Voice Coil Inner Diameter	VC _d	mm	25.73
Rated Noise Power (IEC 2685 18.1)	P	W	30		Gap Height	Gh	mm	6.00
Test Spectrum Bandwidth	20Hz - 5kHz	12 dB/Oct			Maximum Linear Excursion	X_{max}	mm	3.50
					Ferrofluid Type	FF		N/A
					Transducer Size	-	inch	5.25
					Transducer Mass	-	kg	1.062

1 - Piston Band Sensitivity Tolerance

Frequency and Impedance Response:

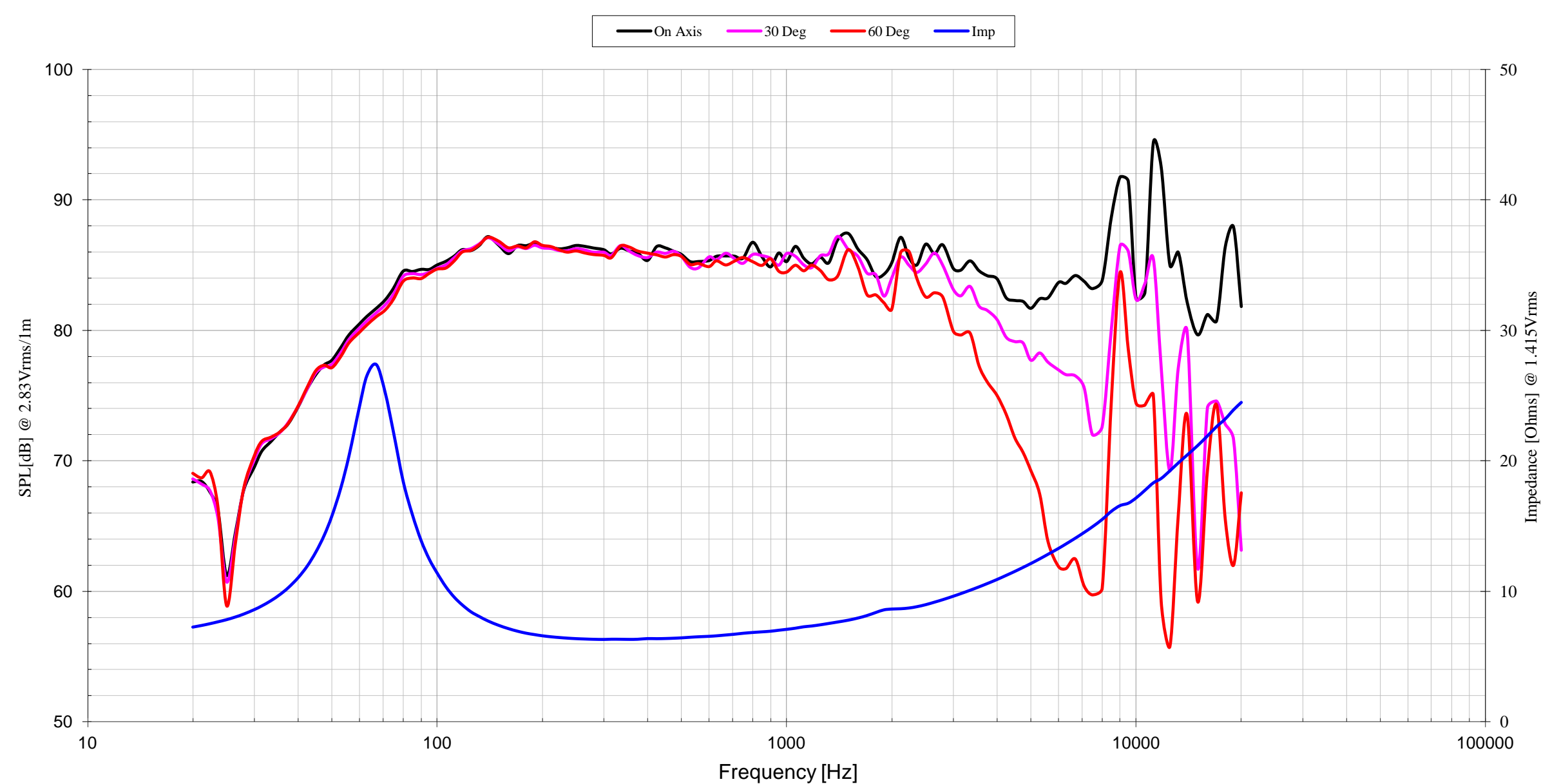

F088-0713A