

- Pressed Steel Basket
- Paper Diaphragm
- Fabric Surround
- Ferrite Magnet
- High Sensitivity

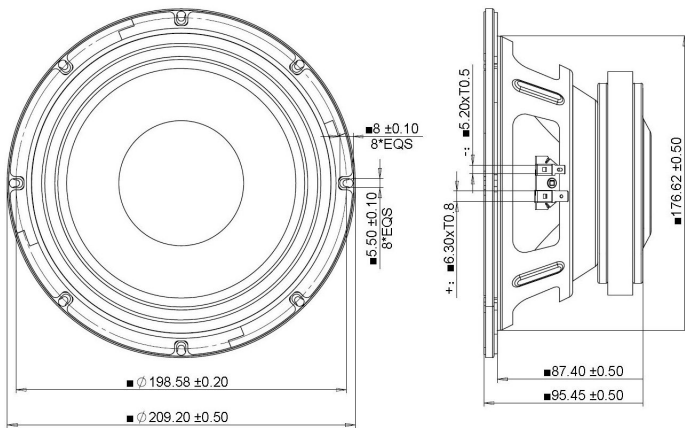

### SPECIFICATIONS

Transducer Size	8	in
Impedance	8	$\Omega$
Frequency Range <sup>1</sup>	70 - 2000	Hz
Sensitivity <sup>2</sup> (2.83V   1W @ 1m)	92.8   92.8	dB
Power Rating (AES2-1984)	147	W
Voice Coil Size	45.5	mm
Air Gap   Winding Height	$H_{ag}   H_{vc}$	6   10.7 mm
Net Weight	2.41	kg

### PARAMETERS <sup>3</sup>

Eff. Piston Area	$S_d$	222	cm <sup>2</sup>
DC Resistance	$R_e$	5.6	$\Omega$
Minimum Impedance	$Z_{min}$	6.5	$\Omega$
Inductance	$L_e$	0.571	mH
Resonance Frequency <sup>4</sup>	$F_s$	74	Hz
Mechanical Q Factor	$Q_{ms}$	3.53	-
Electrical Q Factor	$Q_{es}$	0.418	-
Total Q Factor	$Q_{ts}$	0.37	-
Moving Mass	$M_{ms}$	20.5	g
Compliance	$C_{ms}$	230	$\mu\text{m}/\text{N}$
Equivalent Volume	$V_{as}$	15.9	L
Motor Force Factor	$Bl$	11.3	Tm
Motor Efficiency	$\beta$	22.7	( $Bl$ ) <sup>2</sup> / $R_e$
Linear Excursion <sup>5</sup>	$X_{max}$	4.35	mm
Max Mechanical Excursion <sup>6</sup>	$X_{mech}$	15.1	mm

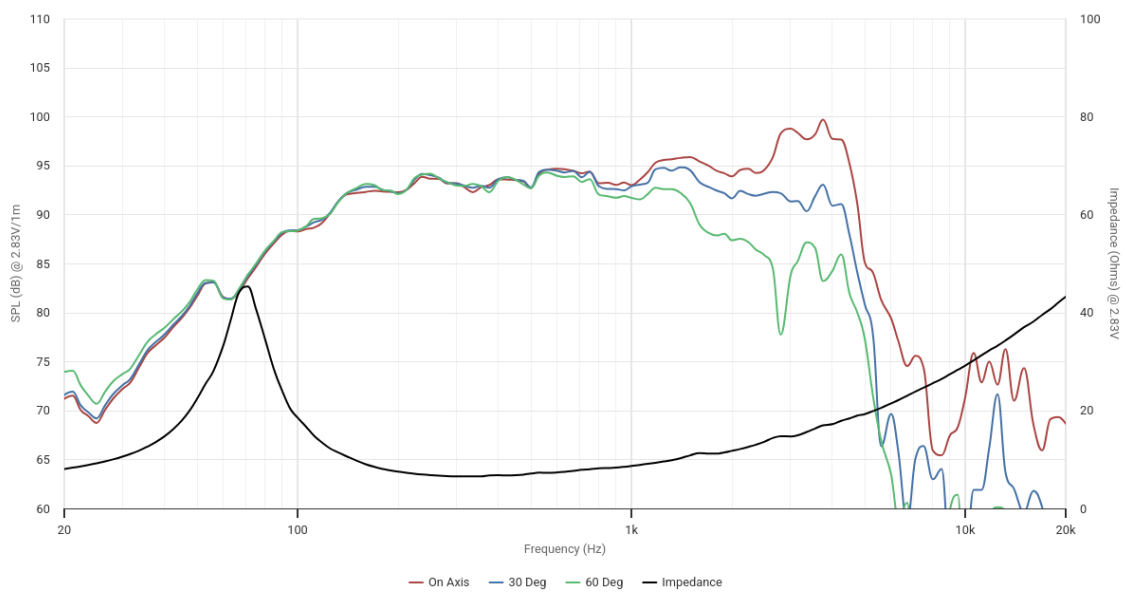

Details on this spec sheet are for reference only and should not be used for setting production limits. Specifications and product cosmetics are subject to change without notice. Peerless is a registered trademark of Tympany Enterprises. All measurements conducted in test lab at 25°C ±10°C, 50%RH ±10%. <sup>1</sup> Specified by Engineering as linear working range of transducer. <sup>2</sup> Measured at 2.83V at 1m and normalized to 1W with respect to nominal impedance. <sup>3</sup> Measured in Free Air without preconditioning, therefore subject to some deviation. <sup>4</sup> Impedance and  $F_s$  value measured under different conditions. <sup>5</sup> Equal/Overhung:  $(H_{vc} - H_{ag})/2 + H_{ag}/3$ . Underhung:  $(H_{ag} - H_{vc})/2 + H_{vc}/3$ . <sup>6</sup> Mechanically limited excursion (e.g. bottoming, spider crash).