

BIANCO-120B150

12" - Open Baffle Woofer - 150W - 95dB

AUDIENCE

- Proprietary cone paper material with silk cotton tree and manila pulp made in-house
- Non-Conducting fibre glass voice coil former for minimum damping
- 2.4" voice coil
- Long life silver lead wires
- Weather-proof coated cone paper
- Designed for open baffle applications



Dimensions & Weight

Overall Diameter	305 mm (12.0 in)
Bolt Circle Diameter	294 mm (11.57 in)
Baffle Cutout Diameter	276 mm (10.86 in)
Mounting Depth	122.5 mm (4.82 in)
Flange and Gasket Thickness	9.6 mm (0.37 in)
Net Weight	3.6 Kg (7.92 lb)
Shipping Box	354 x 354 x 182 mm (13.93 x 13.93 x 7.16 in)
Gross Weight	4.69 Kg (10.33 lb)

Recone Kit

N/A

NOTES :

- (1) AES standard, test mode with continuous pink noise signal (6 dB crest factor; 2 hours) within the F_0 to $10F_0$ power calculated on rated nominal impedance. Loudspeaker in free air
- (2) Maximum power is defined as 3dB greater than nominal power.
- (3) $X_{max} = ((\text{Winding depth} - \text{magnetic gap depth})/2) + (\text{magnetic gap depth}/3)$
- (4) Maximum excursion (p-p) before permanent damage

Specs :

Nominal Impedance	8 Ohm
Minimum Impedance	7.2 Ohm
AES Power Handling (1)	150 W
Maximum Power Handling (2)	300 W
Sensitivity (1W/1m)	95 dB
Frequency Range	41 - 5200 Hz
Voice Coil Diameter	60.5 mm (2.4 in)
Winding Material	Copper
Former Material	Till
Winding Depth	16.25 mm
Magnetic Gap Depth	8 mm (0.3 in)
Flux Density	0.9 T
Magnet	Ferrite
Basket Material	Stamped steel
Demodulation	-
Cone Surround	Double half roll with damping glue
NET Air Volume filled by driver	2.04 liters
Spider Profile	Single constant height waves

Thiele Small Parameters

Fs	41 Hz
Re	7.2 Ohm
Qes	0.6
Qms	3.25
Qts	0.5
Vas	109 liters
Sd	540 cm ³
Xmax (3)	6.79 mm
Xdamage (4)	15 mm
Mms	54 g
BL	13.1 N/A
Le	0.97 mH
Cms	0.27 mm/N
Rms	4.4 Kg/s
Eta Zero	1.29 %
EBP	70

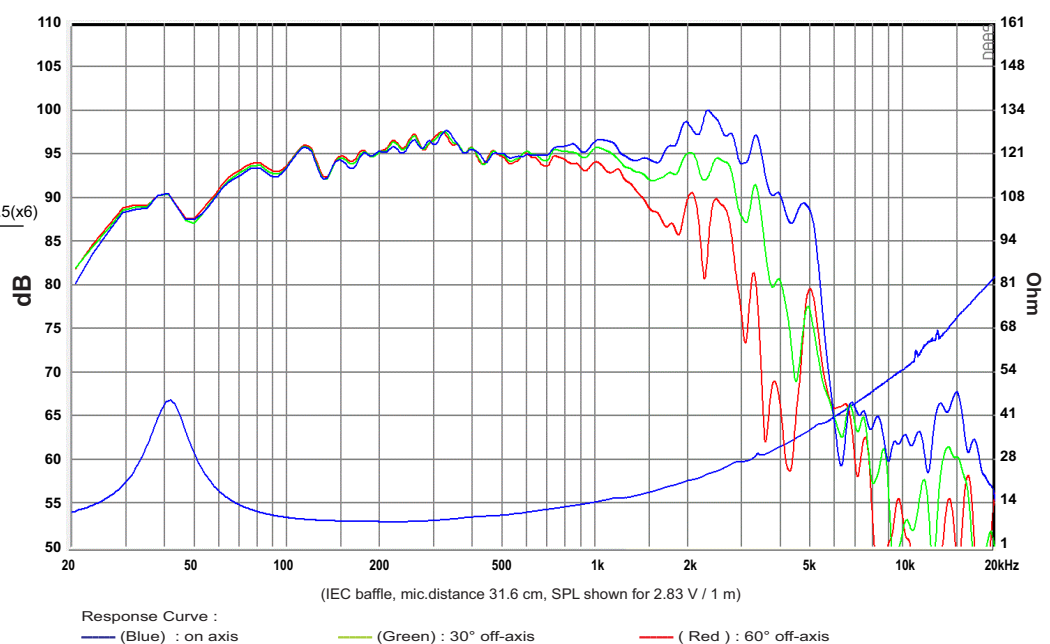
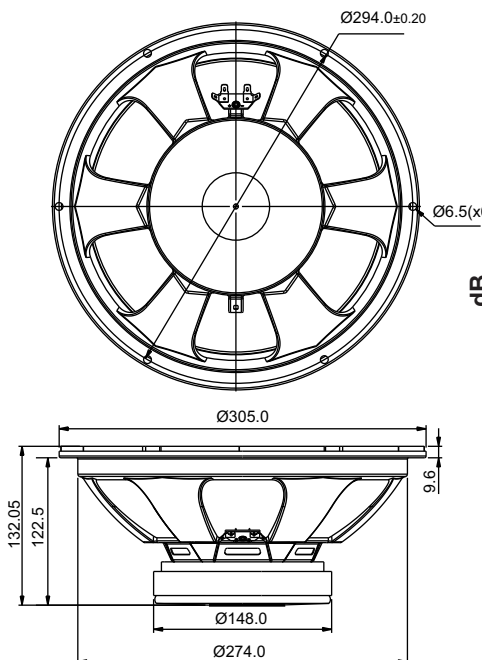

□ Open Baffle Project Driver

INTRODUCING SB AUDIENCE

- With well over 35 years of experience in development and manufacturing of solutions for professional OEM drivers, the time is here to bring out an exclusive PRO audio brand to the world market.
- SB Audience is spawned from the heavyweight manufacturing of SB Acoustics and has serviced well known brands in the PRO audio industry for decades with in house engineering and manufacturing.
- There are three categories within our standard product range: Bianco, achieves good performance at the most reasonable cost. Rosso, aims at high performance at an attractive price, and Nero is our high performance line still achieving exceptional price performance ratio.



OPEN BAFFLE SPEAKER DESIGN & TWO NEW SB AUDIENCE WOOFERS [EDITORIAL]

INTRODUCTION TO THE NEW BIANCO-15OB350 & BIANCO-12OB150 WOOFERS OPTIMISED FOR OPEN BAFFLE DESIGNS

Open baffle loudspeakers are popular for good reason. They can be fitted with large low frequency drivers and they sound “real,” in part because open baffles play with room reflections and sound good even off-axis. A big concern though, is control over the bass response, where the size of the baffle, as well as the choice of the bass drivers are critical. And that is why the engineering team at SB Audience decided to launch new woofers designed for enthusiasts of open baffle applications. Not everyone can accommodate big speakers for music enjoyment at home. But when that’s possible and space allows, dipoles and open baffle loudspeakers are an ideal project for DIY speaker builders and music enthusiasts. They are relatively simple to build, they look impressive, and the overall investment is largely rewarding. Particularly with open baffles, when those speakers are allowed to play in a room with suitable dimensions, where they can sound as loud and dynamic as an actual live concert. As a company with large experience in speaker builder circles and high-end audio applications, SB Acoustics is now building an expanded range of professional transducers under its new brand, SB Audience. And its engineering team, decided to design two large woofers optimized specifically for enthusiasts of open baffles.

The new Bianco 12OB150 12” and the 15” Bianco 15OB350 woofers, both part of the “good performance at the most reasonable cost” catalog from SB Audience, use great-looking paper cone formulations that are also coated to maintain stable properties with temperature and humidity variations. Construction refinements include elegant six-spoke stamped steel baskets that are designed to be seen, and connections using long-life silver lead wires. SB Audience clearly labels the new woofers as “specifically developed for open baffle applications” based on its high total Q (Qts) parameters, suitable for free-air applications.



First off is the 12” Bianco-12OB150 woofer with a generous 2.4” voice coil on a fiber glass former, powerful ferrite magnet motor, specified with a high excursion of 18mm, and with a Total Q of 0.63, making it a good choice woofer for open baffle designs. The 12OB150 uses a proprietary cone paper material, combining silk cotton tree and manila pulp, which is then coated with a weatherproof formula.



New Full-Range 8” SB20FRPC30-8

Also designed for open baffle applications, but offering an impressive Qts of 0.7 is the new 15” Bianco-15OB350 woofer, certainly a great choice for users looking for the most powerful bass in those designs. With a high power handling of 350W (AES) and an excursion of 25mm (11.02 Xmax), the 15OB350 was specified far above average. It also features a proprietary cone paper material made in-house by SBA, ferrite magnet system with 2.5” voice coil on a fibre glass former, with a vented back plate for reduced compression. As SB Audience characterizes, “the sound is punchy, detailed and dynamic in a way not usually encountered with open-baffle woofers.” Also worthy of note for speaker builders is the fact that both woofer datasheets include detailed measurements of overall, bolt circle, and baffle cutout diameters, as well as mounting depth and flange and gasket thickness.