

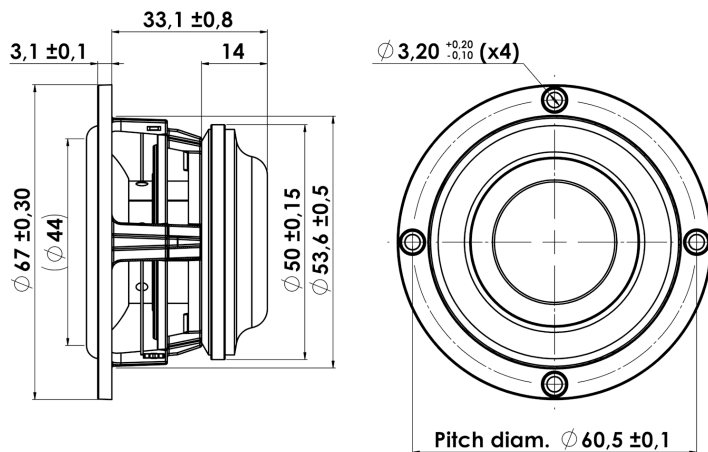

FULLRANGE

5F/8422T01

The Discovery series offer traditional design, superior sound, a solid construction, and a wide range of variants. Combining these elements - plus a wealth of technical features and finesses - gives our customers the possibility of acquiring a tailor-made Scan-Speak solution with very good performance at a reasonable low price point!



KEY FEATURES:

- Powerful Neo Ring Motor, Symmetric Drive
- 1" Voice Coil, Ti Former, European Soft Parts
- Hard Paper Cone, Foam Surround, Long Excursion
- Large Pole Piece Vent, Low Distortion
- Wide Frequency Range
- Extended Copper Cap on Pole Piece

T-S Parameters

Resonance frequency [fs]	93 Hz
Mechanical Q factor [Qms]	5.17
Electrical Q factor [Qes]	0.69
Total Q factor [Qts]	0.61
Force factor [Bl]	3.07 Tm
Mechanical resistance [Rms]	0.21 kg/s
Moving mass [Mms]	1.86 g
Compliance [Cms]	1.58 mm/N
Effective diaph. diameter [D]	44 mm
Effective piston area [Sd]	15.2 cm ²
Equivalent volume [Vas]	0.50 l
Sensitivity (2.83V/1m)	80 dB
Ratio Bl/√Re	1.27 N/√W
Ratio fs/Qts	152.5 Hz

Notes:

IEC specs. refer to IEC 60268-5 third edition.
All Scan-Speak products are RoHS compliant.
Data are subject to change without notice.
Datasheet updated: March 21. 2018.

Electrical Data

Nominal impedance [Zn]	8 Ω
Minimum impedance [Zmin]	6.1 Ω
Maximum impedance [Zo]	43.1 Ω
DC resistance [Re]	6.0 Ω
Voice coil inductance [Le]	0.07 mH

Power Handling

100h RMS noise test (IEC 17.1)	10 W
Long-term max power (IEC 17.3)	20 W

Voice Coil & Magnet Data

Voice coil diameter	26 mm
Voice coil height	6 mm
Voice coil layers	2
Height of gap	2 mm
Linear excursion	± 2 mm
Max mech. excursion	± 5 mm
Unit weight	0.127 kg



FULLRANGE

5F/8422T01

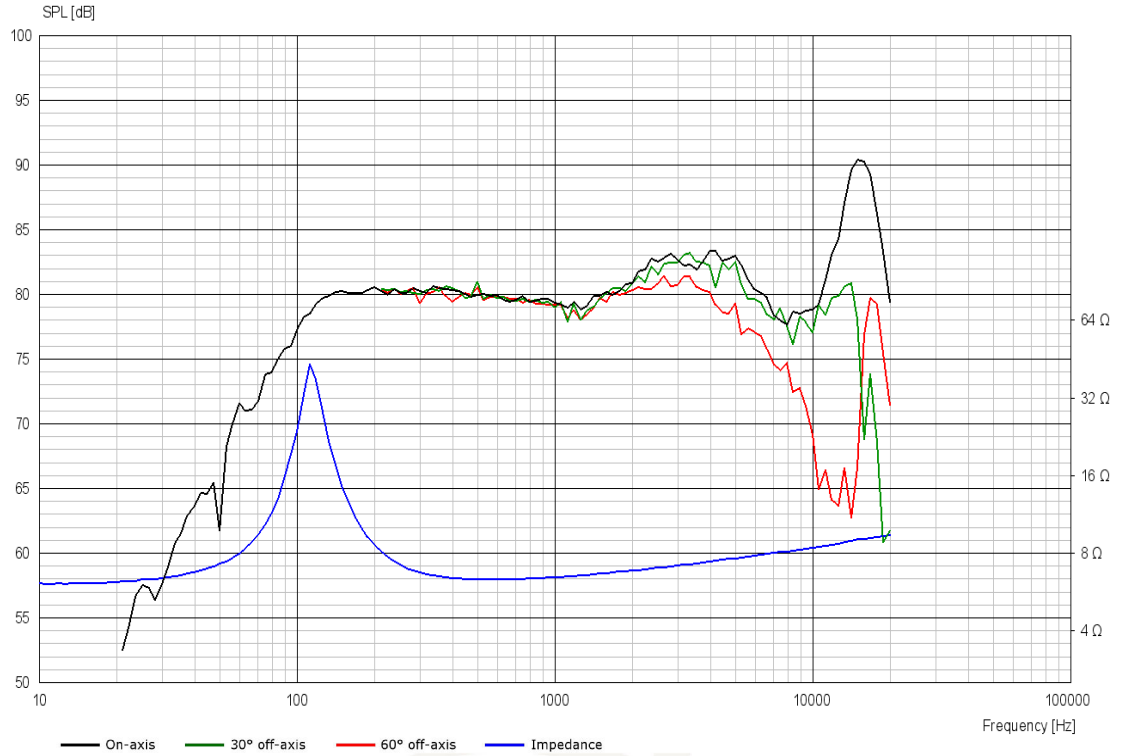

Advanced Parameters (Preliminary)



Electrical data

Resistance [$R_{E'}$]	- Ω
Free inductance [L_{EB}]	- mH
Bound inductance [L_E]	- mH
Semi-inductance [K_E]	- SH
Shunt resistance [R_{SS}]	- Ω

Mechanical Data

Force Factor [BI]	- Tm
Moving mass [M_{MS}]	- g
Compliance [C_{MS}]	- mm/N
Mechanical resistance [R_{MS}]	- kg/s
Admittance [A_{MS}]	- mm/N