

IMFOB & IMFOW

Flush Mount Microphones

Thank you for purchasing this quality Australian Monitor product

The IMFOB and IMFOW flush mount condenser microphones provide an unobtrusive solution for ambient sound recording and sound reinforcement. These Half Omni condenser microphones are tailored specifically for distance mic'ing. The frequency response has been tuned to reduce plosive and overly sibilant sounds. Each model is supplied with rubber isolation rings to keep mechanical noise and rumble to a minimum.

These quality flush mount condenser microphones are highly recommended for ambient recordings, teleconference, surveillance, noise sensing and many other application requiring a ceiling and or table flush mounted microphone.

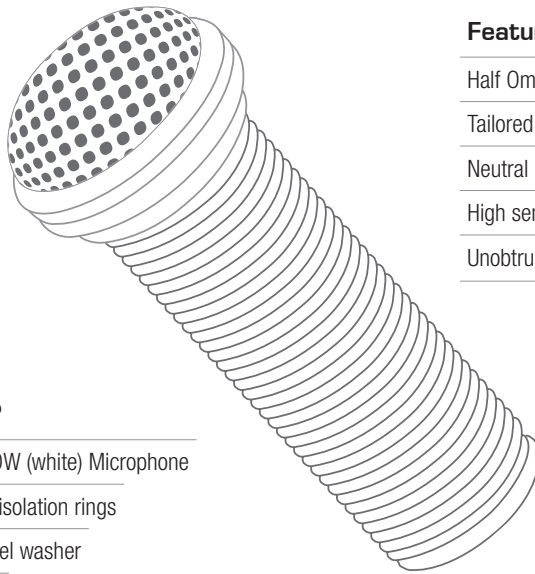

Features

Half Omni polar pattern

Tailored Frequency response

Neutral response

High sensitivity

Unobtrusive design

What's in the box?

1 x IMFOB (black) or IMFOW (white) Microphone

2 x black or white rubber isolation rings

1 x 36.5mm x 3.0mm steel washer

1 x M20x1.5mm steel nut



INSTALLING THE MICROPHONE

Each IMFOB and IMFOW microphone model is supplied with rubber isolation rings. The use of these rings is highly recommended to reduce mechanical noise and room rumble.

- 1 Choose a suitable flat surface to mount the microphone. The microphone is designed to flush mount into any flat surface such as a table or ceiling.
- 2 Using a hole saw or spade bit, drill a 24mm hole through the mounting surface.
- 3 Slide one of the rubber isolation rings on to the barrel of the microphone.
- 4 Slide the microphone barrel into the freshly cut hole.
- 5 Slide the remaining rubber isolation ring on the barrel ensuring both top and bottom rings are properly seated.
- 6 The IMFOB and IMFOW are half omni polar pattern microphones. There is no particular direction you need to point the microphones as they have a 360° pickup pattern.

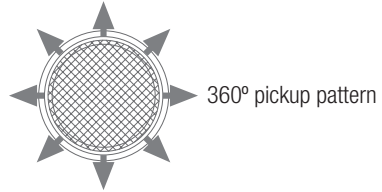

- 7 Slide the washer on to the barrel and spin on the M20 nut until snug. Care should be taken to not over tighten the nut to avoid damage to the microphone and or mounting surface.
- 8 Insert a female 3 pin XLR connector into the microphone barrel.
- 9 Phantom power is required for the microphone to operate. To avoid possible loudspeaker damage ensure the PA system is muted first before you enable phantom power.

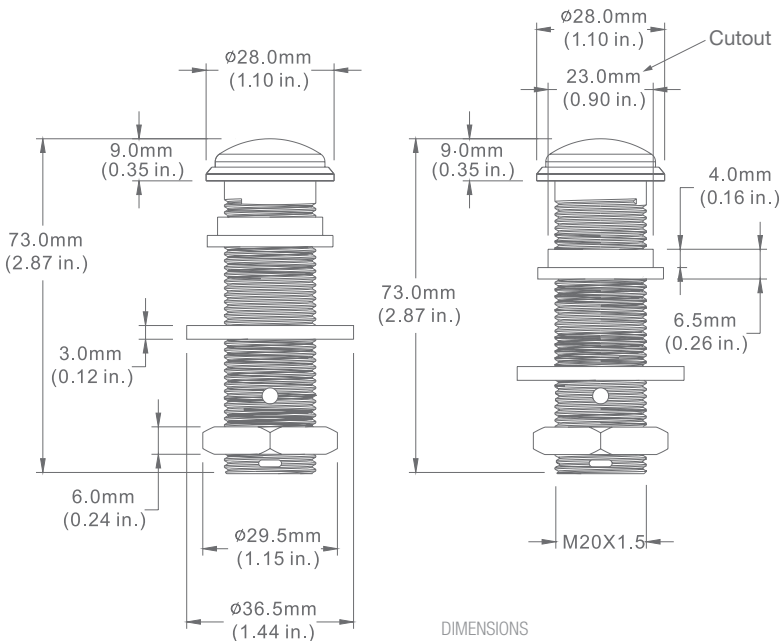

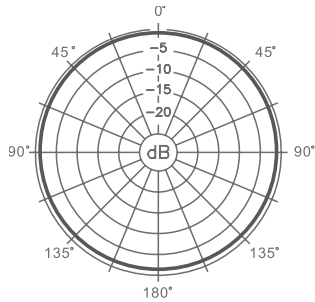

1000 Hz —————

TYPICAL POLAR PATTERN

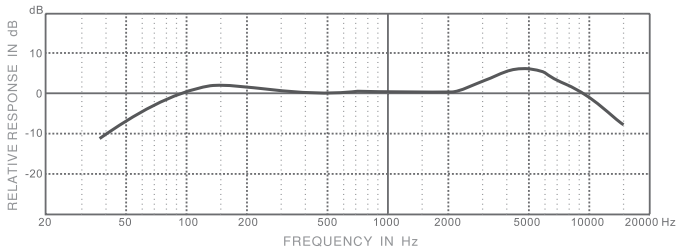

TYPICAL FREQUENCY RESPONSE

Specifications

Transducer Type	Black Electret Condenser
Polar Pattern	Half Omni
Frequency Response	40Hz – 16Khz
Sensitivity	32 mV/Pa -30 dBV
Electrical Impedance	200 Ω
Min. Load Impedance	100 Ω
Max. SPL	132dB @ 1% THD
Finish	Matte Black or Matte White
Connection	Balanced 3 pin XLR Male Pin 2 +, Pin 3 -, Pin 1 shield
Phantom Power	12 – 48Vdc
Current consumption	2 mA
Operating Temp	-10° - +50°C
Dimensions	Ø28 mm x L 73mm
Net Weight	65g
Included Accessories	Rubber isolation rings black or white.

IMPORTANT SAFETY INFORMATION

1. Read these instructions.
2. Keep these instructions.
3. Heed all warnings.
4. Follow all instructions.
5. Do not use this apparatus near water.
6. Clean only with dry cloth.
7. Do not block any ventilation openings. Install in accordance with the manufacturer's instructions.
8. Do not install near any heat sources such as radiators, heat registers, stoves, or other apparatus (including amplifiers) that produce heat.
9. Do not defeat the safety purpose of the polarized or grounding-type plug. A polarized plug has two blades with one wider than the other. A grounding type plug has two blades and a third grounding prong. The wide blade or the third prong are provided for your safety. If the provided plug does not fit into your outlet, consult an electrician for replacement of the obsolete outlet.
10. Protect the power cord from being walked on or pinched particularly at plugs, convenience receptacles, and the point where they exit from the apparatus.
11. Only use attachments/accessories specified by the manufacturer.



Use only with the cart, stand, tripod, bracket, or table specified by the manufacturer, or sold with the apparatus. When a cart is used, use caution when moving the cart/apparatus combination to avoid injury from tip-over.

13. Unplug this apparatus during lightning storms or when unused for long periods of time.
14. Refer all servicing to qualified service personnel. Servicing is required when the apparatus has been damaged in any way, such as power-supply cord or plug is damaged, liquid has been spilled or objects have fallen into the apparatus, the apparatus has been exposed to rain or moisture, does not operate normally, or has been dropped.
15. This appliance shall not be exposed to dripping or splashing water and that no object filled with liquid such as vases shall be placed on the apparatus.
16. Plug this apparatus to the proper wall outlet and make the plug to be disconnected readily operable.
17. Mains plug is used as disconnected device and it should remain readily operable during intended use. In order to disconnect the apparatus from the mains completely, the mains plug should be disconnected from the mains socket outlet completely.
18. Warning: To reduce the risk of fire or electric shock, do not expose this apparatus to rain or moisture.
19. An appliance with a protective earth terminal should be connected to a mains outlet with a protective earth connection.
20. The apparatus should be disconnected from the mains completely before speaker wiring. The speaker output should be properly protected from direct contact and pay attention to speaker connections, terminals and speaker wiring during normal operation.

WARNING!

TO PREVENT FIRE OR SHOCK HAZARD, DO NOT USE THE PLUG WITH AN EXTENSION CORD, RECEPTACLE OR OTHER OUTLET UNLESS THE BLADES CAN BE FULLY INSERTED TO PREVENT BLADE EXPOSURE.
TO REDUCE THE RISK OF FIRE OR ELECTRIC SHOCK, DO NOT EXPOSE THIS APPLIANCE TO RAIN OR MOISTURE.

CAUTION

THESE SERVICING INSTRUCTIONS ARE FOR USE BY QUALIFIED SERVICE PERSONNEL ONLY.
TO REDUCE THE RISK OF ELECTRIC SHOCK DO NOT PERFORM ANY SERVICING OTHER THAN THAT CONTAINED IN THE OPERATING INSTRUCTIONS UNLESS YOU ARE QUALIFIED TO DO SO.



The lightning flash with arrowhead symbol, within an equilateral triangle, is intended to alert the user to the presence of uninsulated "dangerous voltage" within the product's enclosure that may be of sufficient magnitude to constitute a risk of electric shock to persons.

CAUTION

**RISK OF ELECTRIC SHOCK
DO NOT OPEN**

WARNING:

TO REDUCE THE RISK OF ELECTRIC SHOCK, DO NOT REMOVE COVER (OR BACK). NO USER SERVICEABLE PARTS INSIDE. REFER SERVICING TO QUALIFIED SERVICE PERSONNEL.



The exclamation point within an equilateral triangle is intended to alert the user to the presence of important operating and maintenance (servicing) instructions in the literature accompanying the appliance.



For European Union countries: This symbol on the product or its packaging indicates that this product must not be disposed of with other waste.

Instead, it is your responsibility to dispose of your waste equipment by handing it over to a designated collection point for the recycling of waste electrical and electronic equipment.

Please contact your local authority for further details of your nearest designated collection point.

Rating plate and caution marking are marked on the back enclosure of the apparatus

