

REV.	ECN NO.	DESCRIPTION	SIGN	DATE

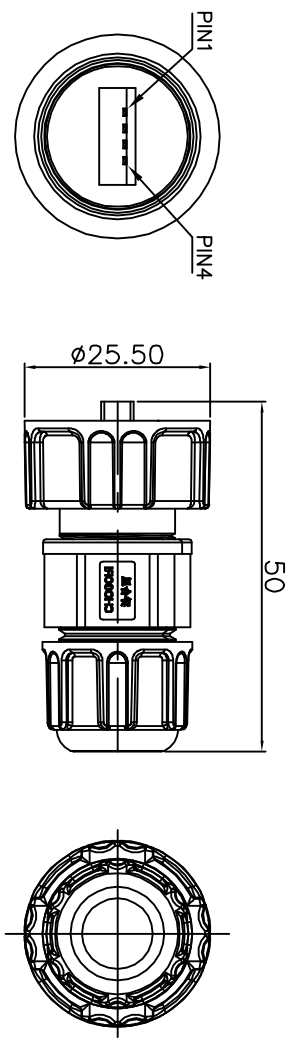
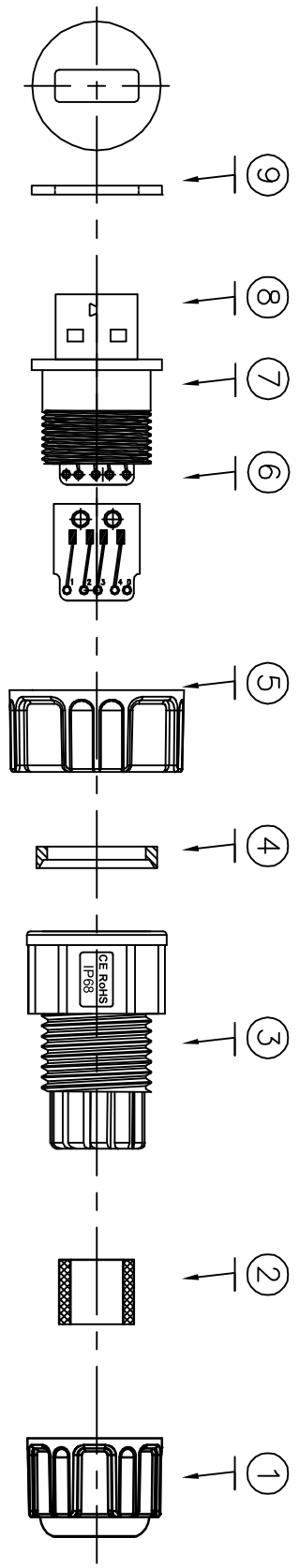

NOTE:  
 1. Ⓞ Important Dimension To Check.  
 2. Contact Resistance:  $\leq 30m\Omega$   
 3. Breakdown Voltage:  $\geq 500V/1Minute$   
 4. Insulation Resistance:  $\geq 1000M\Omega$   
 5. Temperature Rating:  $-45^{\circ}C \sim +85^{\circ}C$   
 6. Seals For Cable OD: Seals B2:  $\phi 3.5mm \sim \phi 6.8mm$   
 7. RoHS

No.	Material No.	Q'ty	Material Description	Remark
9	503-00006-00	1	USB 公头垫片 硅胶/18.8*1.2	
8	901-00007-00	1	USB AM 鱼叉式 SMT	
7	101-00054-00	1	USB公胶头 70G33L料	
6	903-00029-00	1	USB-PCB板-09291长方形板	
5	107-00025-50	1	RJ45 螺旋嵌锁环 (旧款) Seals Ring	
4	503-00011-00	1	Middle-中套垫片 Gasket	
3	108-00017-00	1	Middle 中套 Clamp Ring	
2	502-00001-00	1	Middle-密封环(旧)Seals Ring	$\phi 3.5mm \sim \phi 6.5mm$
1	109-00001-00	1	RJ45,压紧螺母 Seals Nut	

Pin Assignments  
 Front View 前视图

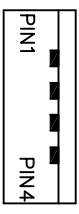

UNIT:mm

TOLERANCE  
 .X ±0.25  
 .XX ±0.15  
 .XXX ±0.05  
 ANGLES ±1°

TITLE  
 USB A Type Male Conn.(Screw Type)

SCALE  
 REV. D1 SIZE A4 SHEET 1 OF 1

深圳乔合里科技有限公司  
 CHOGORI

Ⓞ : Inspection Item

PART NO	DRAWN BY	DATE
34000000-01	Xianming Xu	2013-04-02
DWG NO	CHECKED BY	DATE
CUSTOMER	APPROVED BY	DATE