



DCT-15

USB Audio Converter with Optical



Operation Manual

DISCLAIMERS

The information in this manual has been carefully checked and is believed to be accurate. Cypress Technology assumes no responsibility for any infringements of patents or other rights of third parties which may result from its use.

Cypress Technology assumes no responsibility for any inaccuracies that may be contained in this document. Cypress also makes no commitment to update or to keep current the information contained in this document.

Cypress Technology reserves the right to make improvements to this document and/or product at any time and without notice.

COPYRIGHT NOTICE

No part of this document may be reproduced, transmitted, transcribed, stored in a retrieval system, or any of its part translated into any language or computer file, in any form or by any means—electronic, mechanical, magnetic, optical, chemical, manual, or otherwise—without express written permission and consent from Cypress Technology.

© Copyright 2011 by Cypress Technology.

All Rights Reserved.

Version 1.1 August 2011

TRADEMARK ACKNOWLEDGMENTS

All products or service names mentioned in this document may be trademarks of the companies with which they are associated.





SAFETY PRECAUTIONS

Please read all instructions before attempting to unpack, install or operate this equipment and before connecting the power supply.

Please keep the following in mind as you unpack and install this equipment:

- Always follow basic safety precautions to reduce the risk of fire, electrical shock and injury to persons.
- To prevent fire or shock hazard, do not expose the unit to rain, moisture or install this product near water.
- Never spill liquid of any kind on or into this product.
- Never push an object of any kind into this product through any openings or empty slots in the unit, as you may damage parts inside the unit.
- Do not attach the power supply cabling to building surfaces.
- Use only the supplied power supply unit (PSU). Do not use the PSU if it is damaged.
- Do not allow anything to rest on the power cabling or allow any weight to be placed upon it or any person to walk on it.
- To protect the unit from overheating, do not block any vents or openings in the unit housing that provide ventilation and allow for sufficient space for air to circulate around the unit.

REVISION HISTORY

VERSION NO.	DATE DD/MM/YY	SUMMARY OF CHANGE
V1	06/07/10	Preliminary Release
VR2	05/11/11	ID Material Change
VS3	04/02/14	Updated format/diagrams



CONTENTS

1. Introduction	1
2. Applications	1
3. Package Contents	1
4. System Requirements	1
5. Features	1
6. Operation Controls and Functions	2
6.1 Front Panel.....	2
6.2 Rear Panel	2
7. Connection Diagram	3
8. Specifications	4
8.1 Technical Specifications	4
8.2 Audio Specifications.....	4
9. Acronyms	5





1. INTRODUCTION

The USB Audio Converter with Optical will convert a digital audio signal to analog whilst simultaneously outputting a digital audio signal. It has USB and Optical inputs and is designed to be powered by the USB connection. This optical output can also be linked to an amplifier or sound system that has an Optical S/PDIF input, whilst the analog output can be connected to a display or to an active speaker system to simultaneously output stereo audio.

2. APPLICATIONS

- High performance audio output
- Digital to analog audio conversion
- USB to audio conversion

3. PACKAGE CONTENTS

- USB Audio Converter
- Operation Manual

4. SYSTEM REQUIREMENTS

PC or laptop with USB cables and/or another source input such as a DVD player with an optical cable. Output to an amplifier or active speaker system with optical and RCA cables.

5. FEATURES

- USB 2.0 compatible
- USB audio device class specification v1.0 compatible
- USB High performance 16-bit Stereo, 48/44.1 kHz sampling rate for audio playback
- Optical sampling rate supports up to 192 kHz/24-bit
- Low power consumption

6. OPERATION CONTROLS AND FUNCTIONS

6.1 Front Panel

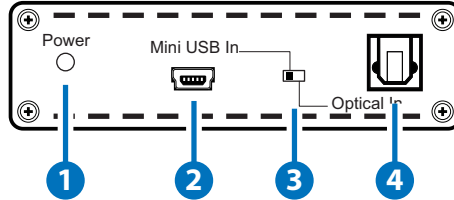

- 1 **Power LED:** The LED will illuminate red when the device is connected to an active power supply.
- 2 **Mini USB In:** Connect to a USB audio source such as a PC/Laptop for audio conversion or to a power supply with a MiniUSB cable.
- 3 **Mini USB and Optical Switch:** This switch selects either the USB or Optical audio sources.
- 4 **Optical In:** Connect an Optical audio source such as a DVD player or games console with an optical cable.

6.2 Rear Panel

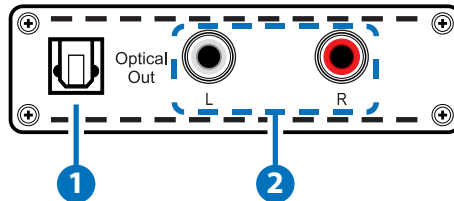

- 1 **Optical Out:** Connect to an amplifier or active speaker system with optical cable for digital audio output.
- 2 **L/R Out:** Connect to an amplifier or active speaker system with RCA cables for analog audio output.

7. CONNECTION DIAGRAM

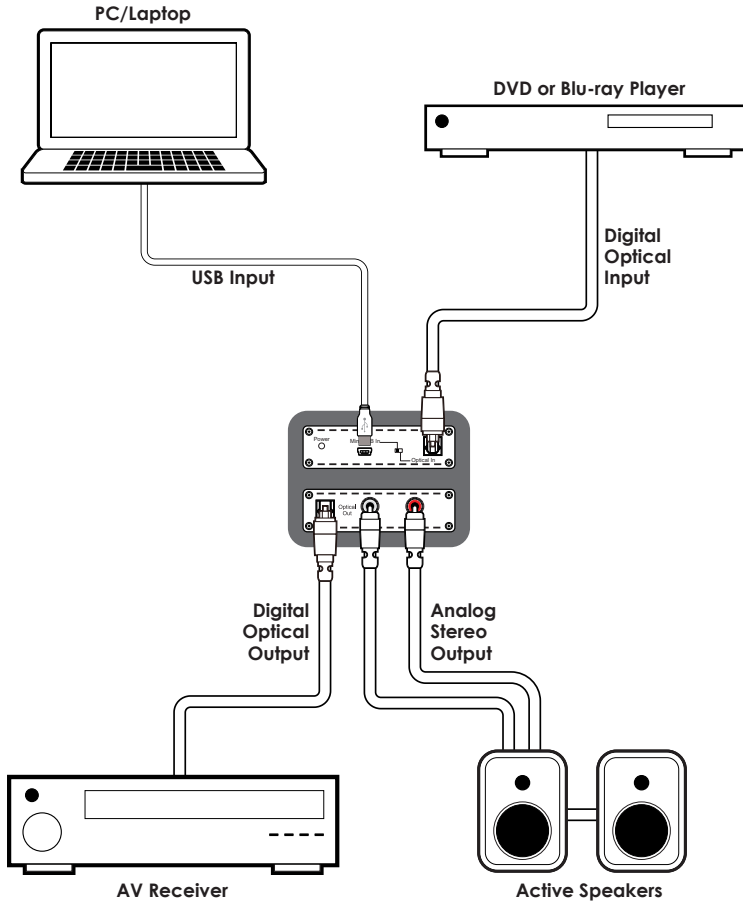

8. SPECIFICATIONS

8.1 Technical Specifications

Input Ports	1×Mini-USB, 1×Optical
Output Ports	1×Optical, 1×Analog Stereo (L/R)
USB Sampling Rates	48 kHz & 44.1 kHz/16-bit
Optical Sample Rates	Up to 192 kHz/24-bit
ESD Protection	Human body model: ±8kV (air-gap discharge) ±6kV (contact discharge)
Dimensions	90mm (W)×120mm (D)×25mm (H)
Weight	250g
Chassis Material	Aluminum
Color	Black
Operating Temperature	0 °C~40 °C / 32 °F~104 °F
Storage Temperature	-20 °C~60 °C / -4 °F~140 °F
Power Consumption	1 W
Relative Humidity	20 ~ 90 % RH (non-condensing)

8.2 Audio Specifications

INPUT REFERENCE LEVEL/FREQ.	OUTPUT	LEVEL	T.H.D+N	FREQ. RESPONSE	SNR	CROSSTALK
OPTICAL 0dBFS 1KHz	L/R	2.1±0.05 Vrms	0.01%↓	0±1 dBrA	>80 dB	<-80 dB
	OPT 48KHZ	0dBFS	0.01%↓	0±0.5 dBFS	>90 dB	<-90 dB



9. ACRONYMS

ACRONYM	COMPLETE TERM
S/PDIF	Sony/Philips Digital Interface Format
USB	Universal Serial Bus



CYPRESS TECHNOLOGY CO., LTD

Home page: <http://www.cypress.com.tw>