



DCT-3

Digital to Analog Stereo Audio Converter



Operation Manual



DISCLAIMERS

The information in this manual has been carefully checked and is believed to be accurate. Cypress Technology assumes no responsibility for any infringements of patents or other rights of third parties which may result from its use.

Cypress Technology assumes no responsibility for any inaccuracies that may be contained in this document. Cypress also makes no commitment to update or to keep current the information contained in this document.

Cypress Technology reserves the right to make improvements to this document and/or product at any time and without notice.

COPYRIGHT NOTICE

No part of this document may be reproduced, transmitted, transcribed, stored in a retrieval system, or any of its part translated into any language or computer file, in any form or by any means—electronic, mechanical, magnetic, optical, chemical, manual, or otherwise—without express written permission and consent from Cypress Technology.

© Copyright 2011 by Cypress Technology.

All Rights Reserved.

Version 1.1 August 2011

TRADEMARK ACKNOWLEDGMENTS

All products or service names mentioned in this document may be trademarks of the companies with which they are associated.





SAFETY PRECAUTIONS

Please read all instructions before attempting to unpack, install or operate this equipment and before connecting the power supply.

Please keep the following in mind as you unpack and install this equipment:

- Always follow basic safety precautions to reduce the risk of fire, electrical shock and injury to persons.
- To prevent fire or shock hazard, do not expose the unit to rain, moisture or install this product near water.
- Never spill liquid of any kind on or into this product.
- Never push an object of any kind into this product through any openings or empty slots in the unit, as you may damage parts inside the unit.
- Do not attach the power supply cabling to building surfaces.
- Use only the supplied power supply unit (PSU). Do not use the PSU if it is damaged.
- Do not allow anything to rest on the power cabling or allow any weight to be placed upon it or any person walk on it.
- To protect the unit from overheating, do not block any vents or openings in the unit housing that provide ventilation and allow for sufficient space for air to circulate around the unit.

REVISION HISTORY

VERSION NO.	DATE DD/MM/YY	SUMMARY OF CHANGE
VS1	20/03/13	Updated format/diagrams
VS2	20/03/12	Updated connection diagram



CONTENTS

1. Introduction.....	1
2. Applications.....	1
3. Package Contents	1
4. System Requirements.....	1
5. Features.....	1
6. Operation Controls and Functions.....	2
6.1 Top Panel	2
6.2 Front Panel.....	2
6.3 Rear Panel	3
6.4 Left Panel	3
7. Connection Diagram	4
8. Specifications	5
9. Acronyms	5





1. INTRODUCTION

The Digital to Analog Stereo Audio Converter (DAC) is an easy way to convert coaxial or optical digital audio signals into analog stereo audio. Accepting digital audio signals from either coaxial or optical source devices, the unit can be switched to determine which digital input signal is active and to be converted into an analog stereo audio signal. It is the converter of choice for those wishing to convert coaxial/optical audio signals to stereo audio in a small form factor.

2. APPLICATIONS

- HDTV with only digital audio output to analog amplifier input
- Secondary digital audio output from an audio streamer for distributing to a second zone
- Improving the digital to analog conversion quality from any stereo digital audio source

3. PACKAGE CONTENTS

- Digital to Analog Stereo Audio Converter
- 5 V/1 A Power Adaptor
- Operation Manual

4. SYSTEM REQUIREMENTS

Digital audio source device such as DVD or CD players with optical or coaxial cables and audio output device such as an amplifier or AV receiver with analog stereo input.

5. FEATURES

- Supports stereo digital audio input (coaxial/optical) and analog audio output (L/R)
- Integrated digital interpolator filter and Digital to Analog Converter (DAC)
- Supports uncompressed 2-Channel LPCM stereo digital audio input
- Supports S/PDIF 24-bit of data for the left and right channels at up to 96 kHz
- Compact size and easy to install

6. OPERATION CONTROLS AND FUNCTIONS

6.1 Top Panel



- 1 **POWER LED:** The LED will illuminate in red when the power is connected.

6.2 Front Panel

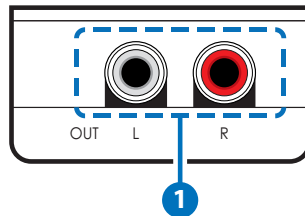

- 1 **L/R OUT:** Connect this output to the analog stereo input of an AV Receiver or audio system.

6.3 Rear Panel

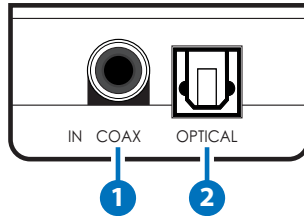

- 1 COAX IN:** Connect this input to the Coaxial digital audio output of a source device such as a DVD or CD player.
- 2 OPTICAL IN:** Connect this input to the Optical digital audio output of a source device such as a games console or Set-top Box.

6.4 Left Panel

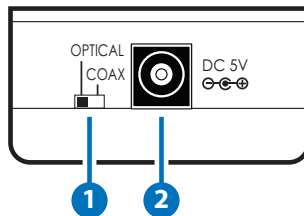

- 1 OPTICAL/COAX Audio Switch:** Select the current audio source, either optical or coaxial.
- 2 DC 5V:** Plug the 5V DC power supply to the unit and connect the adaptor to an AC wall outlet.

7. CONNECTION DIAGRAM

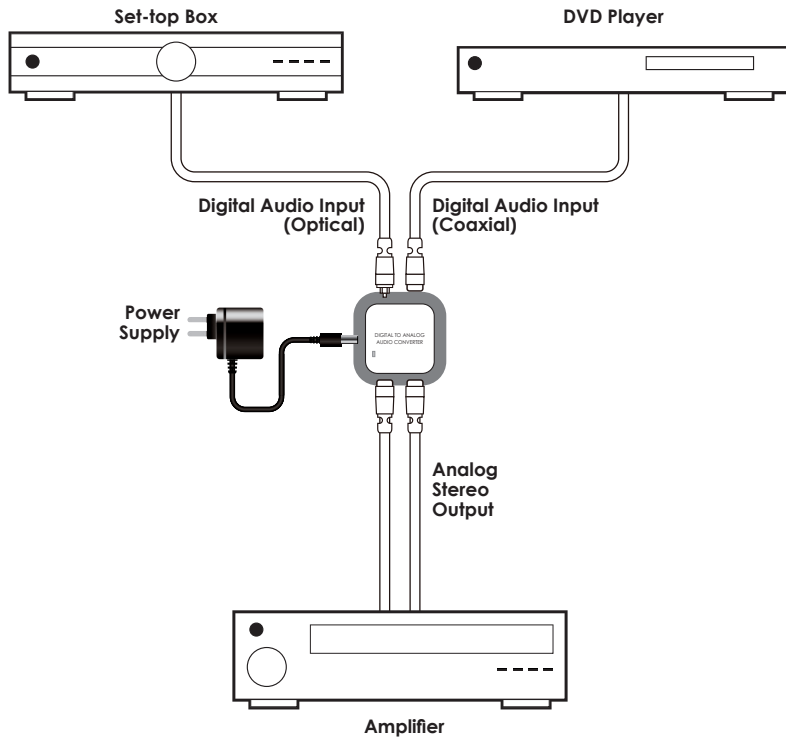



8. SPECIFICATIONS

Input Ports	1×Coaxial, 1×Optical
Input Format	S/PDIF LPCM 2 CH, 24-bit
Sample Frequency	32 kHz, 44.1 kHz, 48 kHz, 96 kHz
Output Ports	1×Analog Stereo (RCA connectors)
Output Level	2Vpp
Power Supply	5 V/1 A linear power adaptor (US/EU standards, CE/FCC/UL certified) or 5 V/1.2 A switching power adaptor (with universal plug, CE/FCC/UL certified)
Dimensions	42 mm (W)×40.5 mm (D)×22 mm (H)
Weight	25 g
Chassis Material	Plastic
Silkscreen Color	White
Operating Temperature	0°C ~ 40°C / 32 °F ~ 104 °F
Storage Temperature	-20°C ~ 60°C / -4°F ~ 140°F
Relative Humidity	20 ~ 90% RH (non-condensing)
Power Consumption	0.5 W

9. ACRONYMS

ACRONYM	COMPLETE TERM
DAC	Digital to Analog Converter
S/PDIF	Sony/Philips Digital Interconnect Format



CYPRESS TECHNOLOGY CO., LTD

Home page: <http://www.cypress.com.tw>

MPM-DCT3