

MOTOR STARTING CAPACITOR

Suntan®

FOR MOTOR STARTING

TS13D CD60

FEATURES

- Small volume, large capacitance
- Low spoilage, stable capability
- Used for the compressor and Air-conditioner and for the pumps.



◆ Specifications

ITEMS	PERFORMANCE CHARACTERISTICS
Operating Temperature Range(°C)	-40°C~+65°C
Rated Voltage	110~330V.AC
Capacitance Tolerance	-10%~+20%
Capacitance	50-1500µF
Loss Tangent	0~+20%
Withstand Voltage Between Terminals	1.2 times working voltage, no break down within 2s
Withstand Voltage Between Terminal And Case	2000VAC, no break down with 60s

◆ Dimensions (mm)

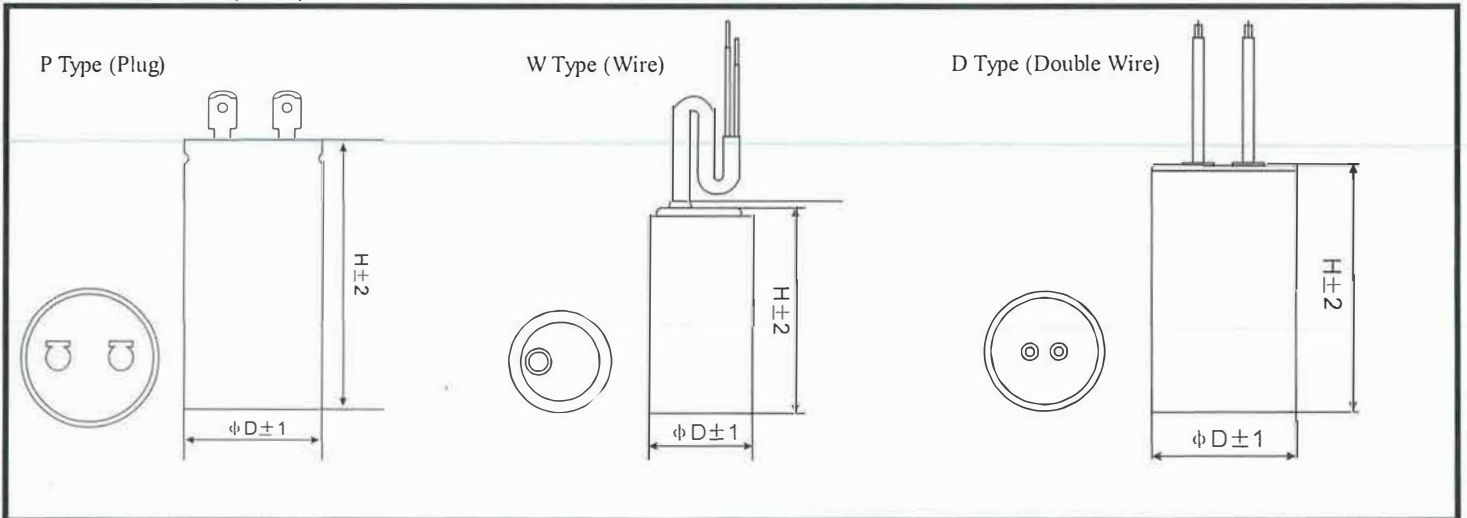

◆ Standard Ratings

Voltage(V)	110/125V	125V	220/275V	250V	330V
Capacitance(µF)	Size D x H (MM)	Size D x H (MM)	Size D x H (MM)	Size D x H (MM)	Size D x H (MM)
50	34x60	34x60	34x70	34x80	42x80
75	34x60	34x60	34x70	34x80	42x80
100	34x60	34x60	34x70	34x80	42x80
150	34x70	34x70	34x70	50x100	50x100
200	40x70	40x70	40x70	50x100	50x100
250	40x90	40x90	45x100	50x100	50x100
300	40x90	40x90	45x100	50x100	50x100
350	45x90	45x90	45x100	50x100	50x100
400	45x100	45x100	45x100	50x100	50x100
500	45x100	45x100	45x100	50x110	---
600	45x100	45x100	50x100	50x110	---
700	50x100	50x100	50x100	---	---
800	50x100	50x100	50x100	---	---
1000	50x100	50x100	---	---	---
1200	50x100	50x100	---	---	---

Note: Specification are subject to change without notice. For more detail and update, please visit our website.