

DP540 Digital Player Operating Manual

Front Panel Controls/Indicators

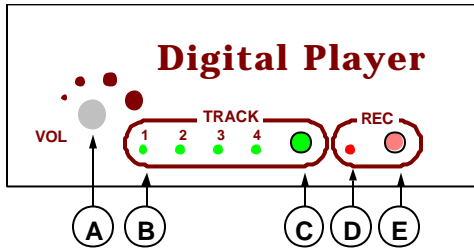

- (A) Output Volume Control**
- (B) Indicators of TRACK 1,2,3,4**
 - a. Display the Track in PLAYING or RECORDING
 - b. Display the Item of PROGRAMMING
 - c. Display the Function of PROGRAMMING
- (C) TRACK ● Button**
- (D) REC Indicator**
 - Off: PLAYING
 - On: RECORDING or PROGRAMMING
 - Blinking: WAITING MODE
- (E) REC ● Button**

Rear Plate Layout

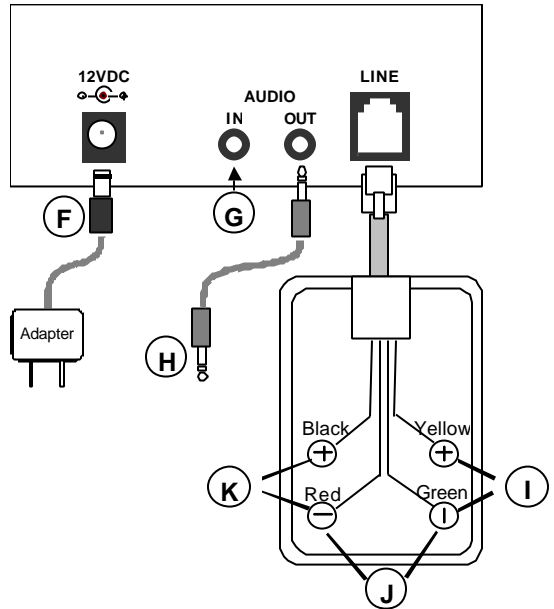

- (F) Power Adapter: 12VDC / 200mA**
- (G) AUDIO IN: Input**
- (H) AUDIO OUT: Output**
- (I) 8 ohm: Output**
- (J) Telephone Interface: In/Output**
- (K) External Trigger Switch**

Operational Flow Chart

- ⌞ Means to press button until all of indicators are blinking.
- ↗ Means to press button quickly.

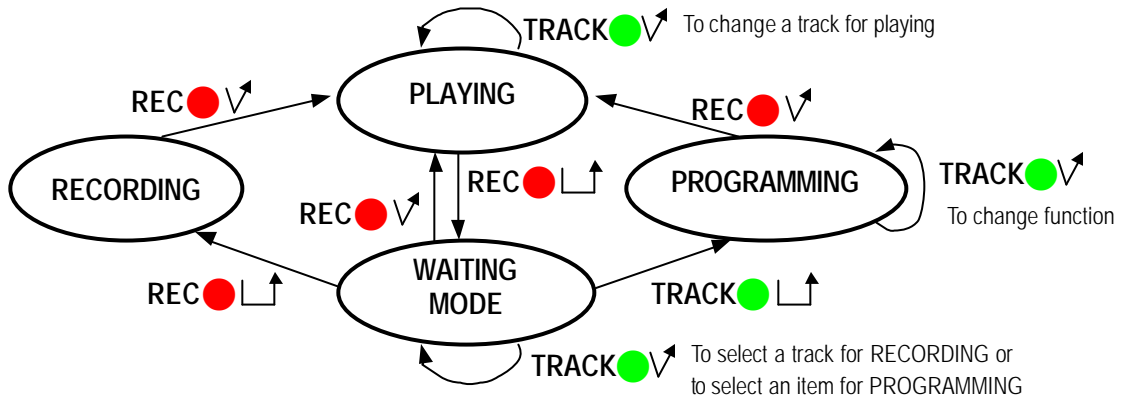

DP540 Digital Player Operating Manual

- 4 tracks of DP540 are available for recording up to 4 message/music. Total recording time is 540 seconds (9 minutes).

Recording

Input the recorded Message/Music from Tape/CD player or PC to DP540 or Voice recording by a telephone handset. Voice recording can be simultaneous recording with music. The procedures are as follows:

Step 1. As shown by Figure, connect the earphone, tape/CD player, PC or phone set to DP540. Make sure REC indicator is off. Otherwise, press **REC**  to turn off the REC indicator.

Step 2. Press and hold **REC**  until all of the indicators are **blinking**.

Step 3. Press **TRACK**  toggle through tracks 1 to 4 and select a track for recording.

Step 4. Press and hold **REC**  until all of the indicators are **blinking**.

Step 5 Release **REC**  button.

The green Track indicator will stay solid.
The red **REC**  indicator will flicker until the recording commences.

Step 6. Play the Tape/CD or PC or/and speak into the handset. (When REC indicator is solid, it means recording has started.)

Step 7. Press **REC**  to complete the recording and return to Playing.

- ◆ The recording will be auto-terminated when 1 second of silence is detected.
- ◆ (REC indicator is NOT on whilst recording is playing.)
- ◆ Any previous recording is automatically erased.

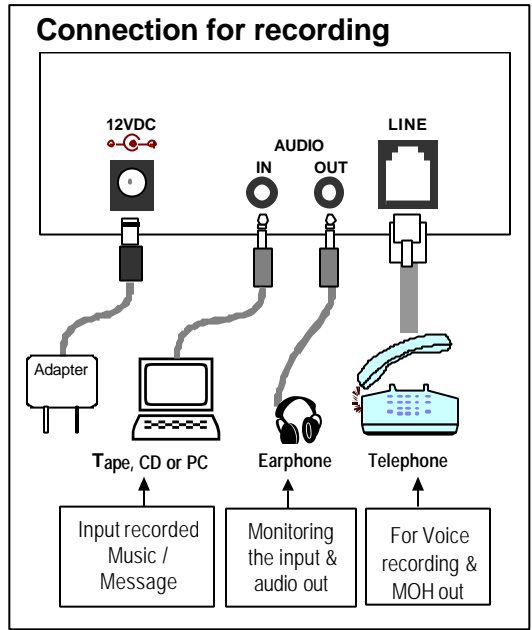

Connect the DP540 output to PBX

1. Connect power source to DP540 via 12VDC power supply.
2. Connect the DP540 "AUDIO OUT" Jack with the PBX MOH port. Dial into PBX from CO line, let the called party hold the line and then adjust the volume to proper position. If the volume is not loud enough while in the maximum position, please connect the "8 Ohm" output of DP540 with the PBX MOH port. If the PBX uses CO line TRUNK port as MOH input, please connect the TRUNK port to DP540 "Telephone Interface".

Don't place the unit close to frequency generator (Power supply, radio broadcast, ...) within 1 meter.

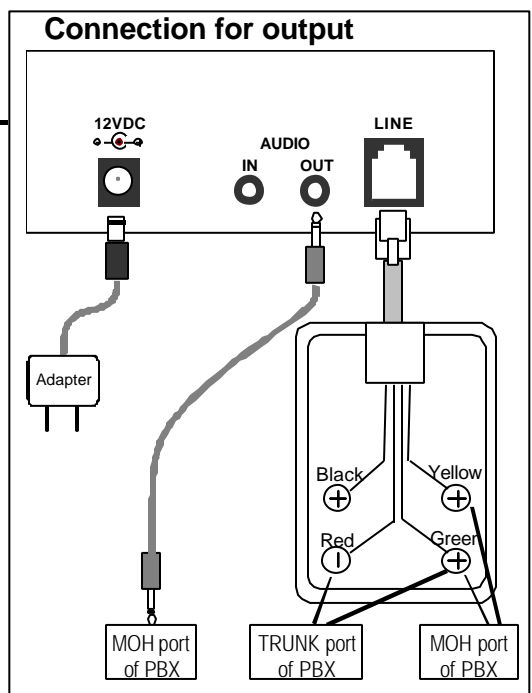

DP540 Digital Player Operating Manual

PROGRAMMING -- Item 1

- Step 1.** Make sure REC indicator is off. Otherwise, press **REC** ● to turn off the REC indicator.
- Step 2.** Press **REC** ● until all of the indicators are blinking. (REC Indicator will also be blinking)
- Step 3.** Press **TRACK** ● to select the "Track 1" Indicator. ("Track 1" Indicator then blinks)
- Step 4.** Press **TRACK** ● until all of the indicators are blinking. (REC indicator will be solid)
- Step 5.** Press **TRACK** ● to change the status of "Track 1,2,3" Indicators corresponding to the required function.

Indicators				Function of Playing
1	2	3	4	
○	○	○	○	Single track with continuous playing. (Default for MOH)
●	○	○	○	Single track with 1 time playing by trigger.
○	●	○	○	Single track with 2 times playing by trigger.
●	●	○	○	Single track with 3 times playing by trigger.
○	○	●	○	Multi-tracks in sequence with continuous playing. (For MOH)
●	○	●	○	Multi-tracks in sequence with 1 time playing by trigger.
○	●	●	○	Multi-tracks in sequence with 2 times playing by trigger.
●	●	●	○	Multi-tracks in sequence with 3 times playing by trigger.

Indicators: ● = ON, ○ = OFF

- 3 ways to trigger the playing:
 - a. By turning on the power.
 - b. By pressing **TRACK** ●
 - c. By External Trigger Switch.
- Pressing **TRACK** ● or External Trigger Switch in Single Track Playing will change to next track.

- Step 6.** Press **REC** ● to complete the programming and return to Playing. (REC indicator will be turned off.)

PROGRAMMING -- Item 2

- Step 1.** Make sure REC indicator is off. Otherwise, press **REC** ● to turn off the REC indicator.
- Step 2.** Press **REC** ● until all of the indicators are blinking. (REC Indicator will then blink)
- Step 3.** Press **TRACK** ● to select the "Track 2" Indicator. ("Track 2" Indicator then blink)
- Step 4.** Press **TRACK** ● until all of the indicators are blinking. (REC indicator will stay on solid)
- Step 5.** Press **TRACK** ● to change the status of "Track 1,2,3" Indicators corresponding to the required function.

Indicators				Recording Activated by Audio	Recording Terminated by Silence
1	2	3	4		
○	○	○	○	Yes (Default)	Yes (Default)
●	○	○	○	No	Yes
○	●	○	○	Yes	No
●	●	○	○	No	No
○	○	●	○	Recording Prohibited	

- If the "Recording Activated by Audio" function is disabled, recording will begin immediately when you switch to Recording.
- If the "Recording Terminated by Silence" function is disabled
- you must press the **REC** ● to complete the recording.

- Step 6.** Press **REC** ● to complete the programming and return to Playing.
(REC indicator will be turned off)

DP540 Digital Player Operating Manual

Application

Music / Message On-Hold

To play music to the waiting customer. Or

To inform callers about goods and services, reinforce the image of company, convey the desired information to callers as you want.

Turn passive waiting time to active promotion period.

Broadcast over public Place

To spread the message or music in public spaces such as Shopping mall, Museum, Airport, Corporate lobby, Casino, Restaurant, Movie theater, Gas station and so on. For connection, just set DP540 to trigger playing mode, and connect "AUDIO OUT" to the "AUX INPUT" of broadcasting system. Plug adapter of DP540 to a timer for the scheduled playing.

Play Advertising Messages In Store Promotion

DP540 is useful and ideal for Department store, Convenience store, Chain store, Retailer, and Grocery store in store advertising or promotion. For connection, just set DP540 to trigger playing mode, and connect "AUDIO OUT" to the "AUX INPUT" of broadcasting system. Advertising message will play when you push the External Trigger Switch.

Display In Exhibition

To perform the continuous and repeated product introduction in Trade show, Theme park, Just set DP540 to trigger playing mode, and connect "8 ohm output" to a speaker. Product introducing message will play when the External Trigger Switch is pushed.

APRA License information Applicable to Australia and New Zealand

New Law: Music on Hold March 2001

A change in legislation to the Copyright Act means the liability for music on hold has moved from the telecommunications carriers such as Telstra and Optus to the end user effective March 2001. Organisations who choose to use copyright music on hold via radio, CD, tape or other storage devices will now need to obtain the permission of the copyright owners through APRA (The Australasian Performing Right Association Ltd). Licence fees are based on the number of external telephone lines you have coming into your organisation on a per site basis.

Music Created by and Provided to you by a specialist MOH company own their own copyright and therefore NO fees are payable to APRA by you the customer.

APRA license fees do not apply in the following cases.

You may commission a MOH company to provide your own customised messages and music. (The MOH will own their own copyright).

You may also ask your PABX supplier to provide the DP540 Digital Player with a pre-recorded melody. (This recording can be changed by the customer at any time.)