

PHONOGRAPHIC PRE-AMPLIFIER

Model:PA005

Congratulations to the purchase of this PA005 pre-amplifier.
Please read this manual thoroughly prior to using the unit.

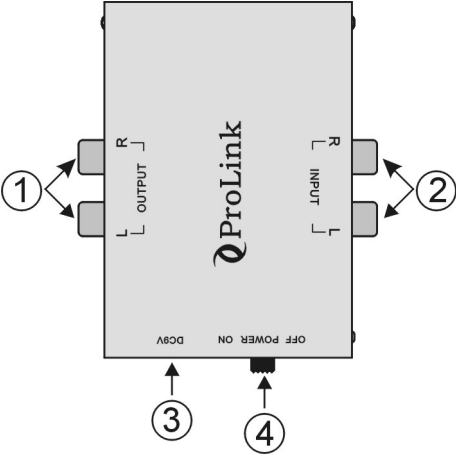

INTRODUCTION

This PA005 stereo pre-amplifier allows a turntable with a magnetic cartridge to be connected to an amplifier without a phono input. It deploys RIAA equalization circuitry that can recover the original sound from a phonographic disc.

PACKAGE CONTENT

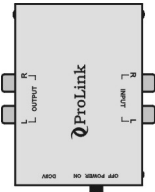

Main Unit



Adaptor

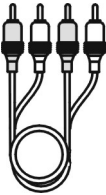

RL Audio Cable

INSTALLATION

Connect the input plugs (2) to your turntable. CAUTION: Make sure that the turntable is fitted with a magnetic cartridge. Connect the output (1) to the input of your amplifier, mixer, sound card, etc. Make sure to select the correct input on the amplifier, mixer, etc. Only use good quality screened cable.

If you want to use the unit in a fixed installation, you can connect it (3) to a regulated 9Vdc power supply. The pre-amplifier can then be switched on and off via the switch (4).

The pre-amplifier can also be powered by a 9V battery, it best work by battery.

- Unscrew the 4 screws on the side and open the unit.
- Connect the 9V battery to the 9V clip.

When the sound quality becomes weak, the battery needs to be replaced.

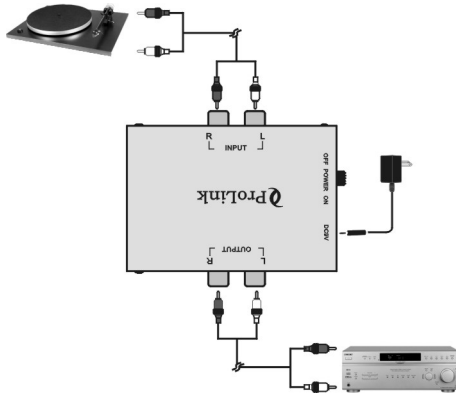

SPECIFICATIONS

Power supply:	9 Vdc
Current consumption:	1 mA (average)
Input impedance:	50 KOhm
Output impedance:	50 KOhm
Amplification:	34dB
Frequency range:	30 Hz – 20 KHz
Compensation:.....	RIAA correction

SAFETY RECOMMENDATIONS

- Do not expose the unit to high temperatures.
- Unplug the unit from the mains during a thunder storm or when it is not in use for a longer period of time.
- If the unit has not been used for a longer period of time, condensation can occur inside the housing. Please let the unit reach room temperature prior to use.
- For indoor use only.
- Keep out of the reach of children.
- Do not use the unit in a humid environment.
- Do not pour liquids on the ventilation holes.
- Unplug the unit from the mains prior to repairs and maintenance.

**Do not attempt to make any repairs yourself. This would invalid your warranty.
Do not make any changes to the unit. This would also invalid your warranty.
The warranty is not applicable in case of accidents or damages caused by inappropriate use
or disrespect of the warnings contained in this manual.**