

HSW-4003-2

8K HDMI 2x1 Switcher



User Manual

VER 1.0

Thank you for purchasing this product

For optimum performance and safety, please read these instructions carefully before connecting, operating or adjusting this product. Please keep this manual for future reference.

Surge protection device recommended

This product contains sensitive electrical components that may be damaged by electrical spikes, surges, electric shock, lighting strikes, etc. Use of surge protection systems is highly recommended in order to protect and extend the life of your equipment.

Table of Contents

| | |
|---|----|
| 1. Introduction..... | 1 |
| 2. Features..... | 1 |
| 3. Package Contents..... | 1 |
| 4. Specifications. | 2 |
| 5. Operation Controls and Functions. | 3 |
| 6. IR Cable Pin Assignment. | 5 |
| 7. IR Remote..... | 6 |
| 8. EDID Settings | 6 |
| 9. API Commands..... | 6 |
| 10. Application Example..... | 13 |

1. Introduction

This 8K 2x1 Switcher can switch any of the two 8K HDMI source signals to one 8K HDMI display. It supports video resolution up to 8K@60Hz 4:2:0 12bit. It features a 4-pin DIP switch for advanced EDID management. It supports digital and analog audio de-embedding function (analog audio output with gain control). It can be controlled via front panel buttons, IR remote and RS-232 API commands. The built-in HDMI signal generator function can quickly diagnose external device connections. This multi-functional product can be widely applied in scenarios of video conference, demonstration, multimedia teaching and other scenarios of requiring big-screen demonstration.

2. Features

- ☆ Video resolution up to 8K60 YCbCr 4:2:0 12bit, 8K30 RGB/YCbCr 4:4:4 12bit or 4K120 RGB/YCbCr 4:4:4 12bit, as specified in HDMI 2.1
- ☆ HDCP 2.3 compliant
- ☆ HDR, HDR10, HDR10+, Dolby Vision, ALLM/VRR pass-through
- ☆ HDMI audio formats pass-through: LPCM, Dolby Digital/Plus/EX, Dolby True HD, Dolby Atmos, DTS, DTS-EX, DTS-96/24, DTS High Res, DTS-HD Master Audio, DSD
- ☆ Digital and analog audio de-embedding (analog audio output with gain control)
- ☆ Auto or manual switching mode
- ☆ Built-in signal equalizer, retiming and driver
- ☆ Advanced EDID management
- ☆ Control via front panel buttons, IR remote and RS-232 API commands
- ☆ Compact design for easy and flexible installation

3. Package Contents

- ① 1x 8K HDMI 2x1 Switcher
- ② 1x IR Remote
- ③ 1x 5pin-3.5mm Phoenix Connector (male)
- ④ 1x 3pin-3.5mm Phoenix Connector (male)
- ⑤ 1x IR Wideband Receiver Cable (1.5m)
- ⑥ 2x Mounting Ear
- ⑦ 4x Machine Screw (KM3*4)
- ⑧ 1x 12V/1A Multinational Locking Power Supply
- ⑨ 1x User Manual

4. Specifications

| Technical | |
|------------------|---|
| HDMI Compliance | HDMI 2.1 |
| HDCP Compliance | HDCP 2.3 |
| Video Bandwidth | 48Gbps |
| Audio Latency | No Latency |
| Video Latency | No Latency |
| Video Resolution | Up to 8K60 YCbCr 4:2:0 12bit, 8K30 RGB/YCbCr 4:4:4 12bit or 4K120 RGB/YCbCr 4:4:4 12bit |
| Color Depth | 8/10/12-bit |
| Color Space | RGB, YCbCr_4:4:4, YCbCr_4:2:2, YCbCr_4:2:0 |
| HDR | HDR, HDR10, HDR10+, Dolby Vision, HLG |
| IR Level | 12Vp-p |
| IR Frequency | Wideband 20K-60KHz |
| Audio Formats | HDMI input/output: LPCM, Dolby Digital/Plus/EX, Dolby True HD, Dolby Atmos, DTS, DTS-EX, DTS-96/24, DTS High Res, DTS-HD Master Audio, DSD Audio de-embedding output: Optical: Up to LPCM/Dolby/DTS 5.1CH Analog: Only LPCM 2CH |
| ESD Protection | IEC 61000-4-2: ±8kV (Air-gap discharge) & ±4kV (Contact discharge) |
| Connection | |
| Input | 2x HDMI IN [Type A, 19-pin female] |
| Output | 1x HDMI OUT [Type A, 19-pin female] 1x OPTICAL AUDIO OUT [S/PDIF, female] 1x L/R AUDIO OUT [5pin-3.5mm Phoenix connector] |
| Control | 1x RS-232 [3pin-3.5mm Phoenix connector] 1x IR CTL [3.5mm stereo mini-jack] 1x SERVICE [USB Type C, Update port] |

| Mechanical | | | | |
|---|--|---------|----------|----------|
| Housing | Metal Enclosure | | | |
| Silkscreen Color | Black | | | |
| Dimensions | 220mm [W] × 110mm [D] × 21.5mm [H] | | | |
| Weight | 595g | | | |
| Power Supply | Input: AC100 - 240V 50/60Hz, Output: DC 12V/1A (US/EU standards, CE/FCC/UL certified) | | | |
| Power Consumption | 5.04W (Max) | | | |
| Operation Temperature | -10°C ~ 45°C / 14°F ~ 113°F | | | |
| Storage Temperature | -20°C ~ 60°C / -4°F ~ 140°F | | | |
| Relative Humidity | 20~90% RH (non-condensing) | | | |
| Recommended HDMI Cable | | | | |
| Video Resolution | 8K | 4K60 | 4K24 | 1080P |
| HDMI Cable Length (HDMI IN / OUT) | 2m/6.6ft (Ultra HDMI 2.1) | 8m/26ft | 12m/39ft | 15m/49ft |
| The use of "Premium High Speed HDMI" cable is highly recommended. | | | | |

5. Operation Controls and Functions

Front Panel

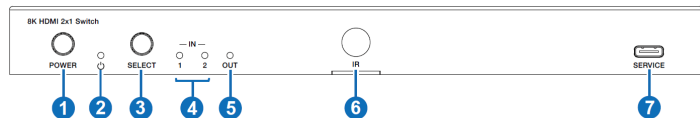

Rear Panel

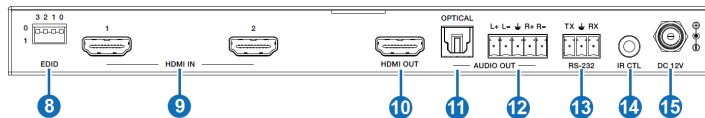

| No. | Name | Function Description |
|-----|--------------------|--|
| 1 | POWER button | Press the POWER button to power on/off the device. |
| 2 | POWER LED | The power LED lights in green when the device is working, and red when the device is in standby. |
| 3 | SELECT button | Signal source selection button. Pressing this button will allow the device to switch any of the two HDMI input signals to the HDMI OUT port. |
| 4 | IN LED (1~2) | When the HDMI IN 1/2 port is selected as the signal source input channel, the corresponding green LED will be on. |
| 5 | OUT LED | When the HDMI OUT port connects a display device and outputs signal, the green LED will be on. |
| 6 | IR Window | IR input signal receiving window. |
| 7 | SERVICE | USB-C port for firmware update, software debugging and API commands controlling. |
| 8 | EDID DIP switch | <p>Use the 4-pin DIP switch to set EDID information.</p> <p>0000- EDID pass-through (Copy from Sink 1) (as factory default)</p> <p>0001- HDMI 1080p@60Hz, Audio 2CH PCM</p> <p>0010- HDMI 1080p@60Hz, Audio 5.1CH DTS/DOLBY</p> <p>0011- HDMI 4K@60Hz 4:4:4, 8-bit, Audio 2CH PCM</p> <p>0100- HDMI 4K@60Hz 4:4:4, 8-bit, Audio 5.1CH DTS/DOLBY</p> <p>0101- HDMI 4K@120Hz 4:4:4, 10-bit HDR/DV, Audio 2CH PCM</p> <p>0110- HDMI 4K@120Hz 4:4:4, 10-bit HDR/DV, Audio 5.1CH DTS/DOLBY</p> <p>0111- HDMI 4K@120Hz 4:4:4, 12-bit HDR/DV, Audio 2CH PCM</p> <p>1000- HDMI 4K@120Hz 4:4:4, 12-bit HDR/DV, Audio 5.1CH DTS/DOLBY</p> <p>1001- HDMI 8K@60Hz 4:2:0, 10-bit HDR/DV, Audio 2CH PCM</p> <p>1010- HDMI 8K@60Hz 4:2:0, 10-bit HDR/DV, Audio 5.1CH DTS/DOLBY</p> <p>1011- HDMI 8K@60Hz 4:2:0, 12-bit HDR/DV, Audio 2CH PCM</p> <p>1100- HDMI 8K@60Hz 4:2:0, 12-bit HDR/DV, Audio 5.1CH DTS/DOLBY</p> <p>1101- HDMI 8K@60Hz 4:2:0, 12-bit HDR/DV, Audio 2CH PCM - Inc VRR/DSC</p> <p>1110- HDMI 8K@60Hz 4:2:0, 12-bit HDR/DV, Audio 5.1CH DTS/DOLBY - Inc VRR/DSC</p> <p>1111- EDID Software if possible or HDMI 1080p@60Hz, Audio 2CH PCM</p> |
| 9 | HDMI IN port (1~2) | HDMI signal input ports, connected to HDMI source device such as DVD or PS5 with an HDMI cable. |

| No. | Name | Function Description |
|-----|----------------------|---|
| 10 | HDMI OUT port | HDMI signal output port, connected to HDMI display device such as TV or Monitor with an HDMI cable. |
| 11 | OPTICAL (AUDIO OUT) | Optical fiber audio output port. |
| 12 | L+L-R+R- (AUDIO OUT) | Analog audio output port, supporting balanced audio output (with a maximum support of 2Vrms) and unbalanced audio output (with a maximum support of 1Vrms). Balanced connection method: L+, L-, $\frac{1}{\sqrt{2}}$ R+, R- Unbalanced connection method: L+, $\frac{1}{\sqrt{2}}$ R+ |
| 13 | RS-232 | RS-232 serial port, used for API commands control. |
| 14 | IR CTL | 12V IR signal receiving port. |
| 15 | DC 12V | DC 12V/1A power input port. |

6. IR Cable Pin Assignment

The pin assignment of the IR Receiver cable is as below:



IR RECEIVER

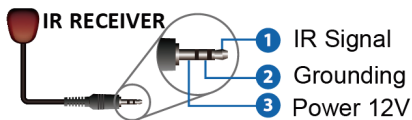

Note: When the angle between the IR receiver and the remote control is $\pm 45^\circ$, the transmission distance is 0-5 meters; when the angle between the IR receiver and the remote control is $\pm 90^\circ$, the transmission distance is 0-8 meters.

7. IR Remote



 : Power on the product or set it to standby mode.

1/2 : Press 1/2 button to select HDMI signal source HDMI IN 1/2 to the HDMI OUT port.

 : Press this button to cyclically switch HDMI signal source HDMI IN 1/2 to the HDMI OUT port.

8. EDID Settings

The switcher supports advanced EDID management. You can set the EDID information in two methods.

Method 1: Via EDID DIP switch

You can dial the EDID DIP switch to set EDID information. For details, please refer to the introduction of EDID DIP switch in “5. Operation Controls and Functions”.

Method 2: Via API commands

When the EDID DIP switch is dialed to “1111”, you can send API commands to set EDID information. For the details of API commands, please refer to “9. API Commands”.

9. API Commands

The switcher also supports API commands control. Connect the RS-232 port or the SERVICE port of the switcher to a PC. Then open a Serial Command tool on PC to send ASCII commands to control the switcher.

The ASCII command list about the switcher is shown as below.

ASCII Commands

- Service port (USB-C virtual RS-232) communication protocol (Internal debug)
Baud rate: 115200 (Fixed) Data bit: 8 Stop bit: 1 Parity bit: none
The end mark of command is "<CR><LF>"
 - Phoenix RS-232 port communication protocol (Connect to control system)
Baud rate: 4800~115200 (Configurable) Data bit: 8 Stop bit: 1 Parity bit: none
The end mark of command is "<CR><LF>"
- x, y, z are parameters. Error Code describe: E00 -> unknown command E01 -
> parameter out of range E02 -> get the error edid data

| Command Code | Function Description | Example | Feedback | Factory Default |
|------------------|--|-------------------------------|---|-----------------|
| ? | Get the list of all commands | ? | list all commands | |
| help | Get the list of all commands | help! | list all commands | |
| get fw version | Get firmware version | get fw version | mcu boot:vx.xx.xx mcu app :vx.xx.xx | |
| set power on/off | Set device power on/off | set power on set power off | power on system initializing... initialization finished! fw version x.xx.xx power off | |
| get power | Get device power status | get power | power on /power off | |
| set reboot | Reboot the device | set reboot | reboot... system initializing... initialization finished! fw version x.xx.xx | |
| set reset | Reset to factory defaults | set reset | reset to factory defaults system initializing... initialization finished! fw version x.xx.xx | |
| get status | Get system status | get status | Please refer to the note at the end of the list. | |
| set IR on/off | Set IR on/off | set IR on set IR off | IR on IR off | on |
| get IR | Get IR on/off status | get IR | IR on /IR off | |
| set key on/off | Set front panel key on/off | set key on set key off | key on key off | on |
| get key | Get front panel key on/off status | get key | key on/off | |
| set baud x | Set RS-232 baud rate to x bps x=1: 4800 x=2: 9600 x=3: 19200 x=4: 38400 x=5: 57600 x=6: 115200 | set baud 6 | baud rate 115200 | 115200 |

| Command Code | Function Description | Example | Feedback | Factory Default |
|----------------------|--|--------------------------|--|-----------------|
| get baud | Get RS-232 baud rate | get baud | baud rate 115200 | |
| set input x | Set input video (x=0~2) x=0: Off x=1~2: HDMI input 1~2 | set input 1 | input HDMI 1 | 1 |
| get input | Get input port | get input | input HDMI 1 | |
| get hdmi5v | Get input HDMI 5V | get hdmi5v | HDMI 1: 5V HDMI 2: none | |
| set autoswitch x | Set auto-switching on/off (HDMI 5V detection) x=On, Off | set autoswitch on | autoswitch on autoswitch off | on |
| get autoswitch | Get auto-switching status | get autoswitch | autoswitch on/off | |
| set output display y | Set output display mode (y=0~3) y=0: Off (disable TMDS output) y=1: Input video y=2: AVMUTE y=3: Internal pattern | set output display 2 | output display off (disable TMDS output) output display input video output display AVMUTE output display internal pattern | 1 |
| get output display | Get output display mode | get output display | output display off/input video/AVMUTE/internal pattern | |
| set output HDCP y | Set output HDCP mode (y=0~4) y=0: Reserved y=1: Follow sink y=2: Follow source y=3: Force HDCP 1.4 y=4: Force HDCP 2.2 | set output HDCP 1 | output HDCP follow sink output HDCP follow source output HDCP force HDCP 1.4 output HDCP force HDCP 2.2 | 1 |
| get output HDCP | Get output HDCP mode | get output HDCP | output HDCP follow sink/follow source/ force HDCP 1.4/ force HDCP 2.2 | |
| set analog mute x | Set analog audio mute on/off x=On, Off | set analog mute on | analog mute on analog mute off | off |
| get analog mute | Get analog audio mute status | get analog mute | analog mute on analog mute off | |
| set analog gain x | Set analog audio gain (x=0dB ~ -79dB) | set analog gain -79dB | analog gain -79dB | 0dB |
| get analog gain | Get analog audio gain value | get analog gain | analog gain -79dB | |

| Command Code | Function Description | Example | Feedback | Factory Default |
|-------------------|--|----------------------|-------------------------------|-----------------|
| set generator x y | Set internal signal generator resolution (x=1~15) pattern (y=1~13) x=01: 8K30Hz x=02: 4K120Hz x=03: 4K100Hz x=04: 5K60Hz x=05: 5K50Hz x=06: 5K30Hz x=07: 5K25Hz x=08: 5K24Hz x=09: 4K60Hz x=10: 4K50Hz x=11: 4K25Hz x=12: 4K24Hz x=13: 1080P60Hz x=14: 480P60Hz x=15: 5760P50Hz y=01: Color bar y=02: Checkboard y=03: Strip y=04: Red y=05: Green y=06: Blue y=07: White y=08: Ramp y=09: Red ramp y=10: Green ramp y=11: Blue ramp y=12: PRBS y=13: Black | set generator 1 1 | generator 8K30Hz color bar | |
| get generator | Get internal signal generator output resolution and pattern | get generator | generator 8K30Hz color bar | |

| Command Code | Function Description | Example | Feedback | Factory Default |
|-----------------|--|--|--|--------------------------------|
| set edid x to y | Set input ports (x=0~2) to EDID (y=0~32) x=0: all inputs x=1~2: HDMI input 1~2 y=00: HDMI 1080p@60Hz, Audio 2CH PCM (default) y=01: HDMI 1080p@60Hz, Audio 5.1CH DTS/DOLBY y=02: HDMI 1080p@60Hz, Audio 7.1CH DTS/DOLBY/HD y=03: HDMI 4K@60Hz 4:4:4, 8-bit, Audio 2CH PCM y=04: HDMI 4K@60Hz 4:4:4, 8-bit, Audio 5.1CH DTS/DOLBY y=05: HDMI 4K@60Hz 4:4:4, 8-bit, Audio 7.1CH DTS/DOLBY/HD y=06: HDMI 4K@120Hz 4:4:4, 8-bit, Audio 2CH PCM y=07: HDMI 4K@120Hz 4:4:4, 8-bit, Audio 5.1CH DTS/DOLBY y=08: HDMI 4K@120Hz 4:4:4, 8-bit, Audio 7.1CH DTS/DOLBY/HD y=09: HDMI 4K@120Hz 4:4:4, 10-bit HDR/DV, Audio 2CH PCM y=10: HDMI 4K@120Hz 4:4:4, 10-bit HDR/DV, Audio 5.1CH DTS/DOLBY y=11: HDMI 4K@120Hz 4:4:4, 10-bit HDR/DV, Audio 7.1CH DTS/DOLBY/HD y=12: HDMI 4K@120Hz 4:4:4, 12-bit HDR/DV, Audio 2CH PCM y=13: HDMI 4K@120Hz 4:4:4, 12-bit HDR/DV, Audio 5.1CH DTS/DOLBY y=14: HDMI 4K@120Hz 4:4:4, 12-bit HDR/DV, Audio 7.1CH DTS/DOLBY/HD y=15: HDMI 4K@120Hz 4:4:4, 12-bit HDR/DV, Audio 2CH PCM - Inc VRR/DSC y=16: HDMI 4K@120Hz 4:4:4, 12-bit HDR/DV, Audio 5.1CH DTS/DOLBY - Inc VRR/DSC y=17: HDMI 4K@120Hz 4:4:4, 12-bit HDR/DV, Audio 7.1CH DTS/DOLBY/HD - Inc VRR/DSC | set edid 0 to 0 set edid 1 to 1 | all inputs EDID: HDMI 1080p@60Hz, Audio 2CH PCM (default) input 1 EDID: HDMI 1080p@60Hz, Audio 5.1CH DTS/DOLBY | HDMI 1080p@60Hz, Audio 2CH PCM |

| Command Code | Function Description | Example | Feedback | Factory Default |
|-----------------|---|--|--|--------------------------------|
| set edid x to y | y=18: HDMI 8K@60Hz 4:2:0, 10-bit HDR/DV, Audio 2CH PCM y=19: HDMI 8K@60Hz 4:2:0, 10-bit HDR/DV, Audio 5.1CH DTS/DOLBY y=20: HDMI 8K@60Hz 4:2:0, 10-bit HDR/DV, Audio 7.1CH DTS/DOLBY/HD y=21: HDMI 8K@60Hz 4:2:0, 12-bit HDR/DV, Audio 2CH PCM y=22: HDMI 8K@60Hz 4:2:0, 12-bit HDR/DV, Audio 5.1CH DTS/DOLBY y=23: HDMI 8K@60Hz 4:2:0, 12-bit HDR/DV, Audio 7.1CH DTS/DOLBY/HD y=24: HDMI 8K@60Hz 4:2:0, 12-bit HDR/DV, Audio 2CH PCM - Inc VRR/DSC y=25: HDMI 8K@60Hz 4:2:0, 12-bit HDR/DV, Audio 5.1CH DTS/DOLBY - Inc VRR/DSC y=26: HDMI 8K@60Hz 4:2:0, 12-bit HDR/DV, Audio 7.1CH DTS/DOLBY/HD - Inc VRR/DSC y=27: DVI 1920x1080@60Hz, Audio None y=28: DVI 1920x1200@60Hz, Audio None y=29: HDMI 1920x1200@60Hz, Audio 2CH PCM y=30: User EDID 1 y=31: User EDID 2 y=32: EDID pass-through (Copy from Sink 1) | set edid 0 to 0 set edid 1 to 1 | all inputs EDID: HDMI 1080p@60Hz, Audio 2CH PCM (default) input 1 EDID: HDMI 1080p@60Hz, Audio 5.1CH DTS/DOLBY | HDMI 1080p@60Hz, Audio 2CH PCM |
| get edid x | Get input ports EDID x=0: all inputs x=1~2: HDMI input 1~2 | get edid 0 | input 1 EDID: HDMI 1080p@60Hz, Audio 2CH PCM (default) input 2 EDID: HDMI 1080p@60Hz, Audio 2CH PCM (default) | |
| get edid data x | Get input ports EDID data x=0: all inputs x=1~2: HDMI input 1~2 | get edid data 0 | HDMI input 1 EDID <00 FF FF FF...> HDMI input 2 EDID <00 FF FF FF...> | |

| Command Code | Function Description | Example | Feedback | Factory Default |
|------------------------|--|--|--|-----------------|
| set user edid x <y> | Set user defined EDID (x=1~2) x=1: User Defined 1 x=2: User Defined 2 y = 00 FF FF FF (y is 256 bytes EDID data) | set user edid 1 <00 FF FF FF> | user defined 1 EDID is loaded successfully | |
| get user edid x | Get user defined EDID (x=1~2) x=1: User Defined 1 x=2: User Defined 2 | get user edid 1 | user defined 1 EDID <00 FF FF FF....> | |

Note: The feedback of the command of "get status" is as following. (The middle line ends with <LF> <CR> and the last line ends with <CR><LF>.)

=====
Status Info 8K 2x1 Switcher
FW 1.0.0

| | | | | |
|-------|-----|----|--------|------------|
| Power | Key | IR | Baud | Autoswitch |
| On | On | On | 115200 | On |

| | | |
|-------|-----------|----------------------------|
| Input | Cable | EDID |
| 01 | Connected | DIP_0000:EDID pass-through |
| 02 | Connected | DIP_0000:EDID pass-through |

| | | | | | | |
|--------|--------|-----------|----------------|------------|------------|------|
| Output | FromIn | Cable | Resolution | ColorSpace | ColorDepth | HDCP |
| 01 | 01 | Connected | 3840x2160p60Hz | YUV 4:2:0 | 12bit | Sink |

=====

10. Application Example

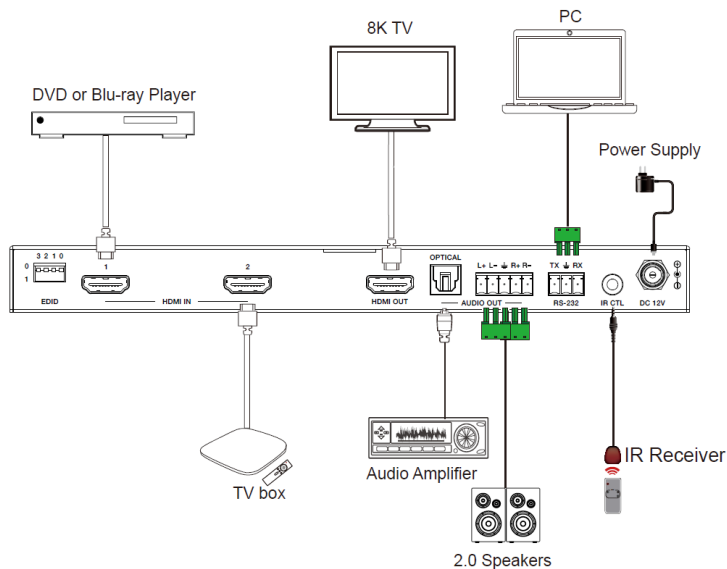

HDMI™
HIGH-DEFINITION MULTIMEDIA INTERFACE

The terms HDMI and HDMI High-Definition Multimedia interface, and the HDMI Logo are trademarks or registered trademarks of HDMI Licensing LLC in the United States and other countries.