

PA2126 - 200mm (8") 100V 15W High Power Fast-Fix EWIS Ceiling Speaker

- ✓ High power output
- ✓ Excellent speech intelligibility
- ✓ High quality speaker driver developed for BGM, paging and emergency warning applications
- ✓ Flip-lock mounting system reduces installation time.
- ✓ Fitted with 4 way wire protect terminal block for loop in, loop out wiring as required by Australian Standards.
- ✓ Fitted with supervisory capacitor for line monitoring.
- ✓ Stylish ABS surround and aluminium mesh grille.
- ✓ 5 year warranty.

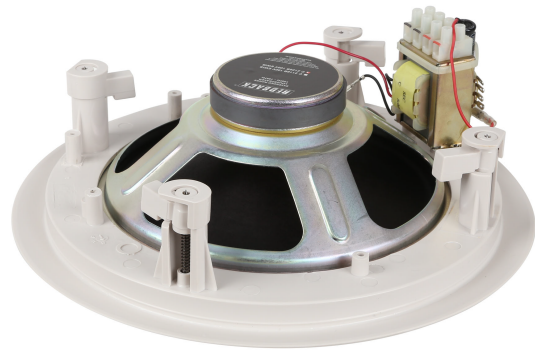

Application

The PA2126 is a high power PA speaker designed for EWIS (fire & evacuation) installations where high SPL is required.

Emergency Warning & Intercommunications Systems (EWIS)

This speaker is designed for use in installations designed to deliver both verbal and tone announcements to occupants for evacuation and alarm conditions.

It is fitted with line monitoring capacitor and 4 way wire protect terminal connection.

About Redback Testing @ Speaker Drivers

Each custom designed speaker and transformer combination has been specifically engineered to ensure a wide frequency range and dispersion angle, plus a high sound pressure level (SPL) ensuring excellent music and speech intelligibility; which is highly desirable for emergency paging applications.

Redback® drivers exhibit optimum frequency response and efficiency for BGM, paging and EWIS applications. The transformers are wound on professional grade grain oriented steel cores for high efficiency and extended frequency response.

Each transformer is fitted with multiple power tapings which are selected via a tab on the side of the transformer

Installation Guidelines

Redback® "Fast-Fix" speaker utilise a time saving flip lock mounting method. It results in a finish with no visible screw heads or caps. The flip lock tabs slide outwards as the speaker is screwed into the hole, securing the speaker to the ceiling material from the top side. Suitable for use with any 8-33mm ceiling tile, including gyprock, mineral fibre or fixed gyprock ceilings. We recommend a speaker hole of 238mm. This is easily cut using the T 2314 holesaw.

The neutral white RAL colour of C 2126B provides an architecturally unobtrusive finish to virtually any installation.

The transformer is fitted with a 4 way wire protect screw terminal block. This is suitable for loop in, loop out cabling

Testing

Redback® drivers are subject to strenuous factory testing reducing the risk of unit failure or performance reduction over time. Each driver has a power rating well above the max tapping of the transformer, ensuring reliable operation and excellent longevity

Dimensions & Transformer Detail

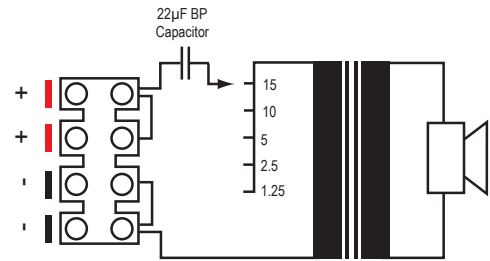
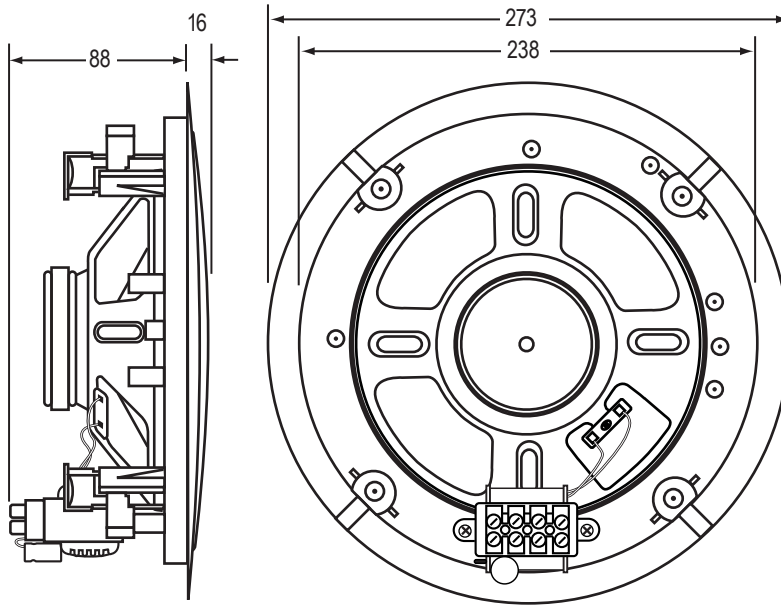

Power tap shown selected to factory default setting.

Specifications

Electrical

Power taps:	1.25, 2, 5, 10, 15W
SPL 1W @ 1m:	91dB @ 1kHz (+/- 2dB)
Frequency response:	55Hz-15kHz
Connection:	4 way terminal block + 22uf bipolar capacitor

Mechanical

Grille material:	ABS surround, aluminium mesh grille
Driver construction:	Paper twin cone
Ceiling cutout:	238Ømm
Grille diameter:	273Ømm
Mounting depth:	88mm (including ceiling tile thickness)
Overall weight:	1.24kg

Colour:	White
---------	-------

Environmental

Operating temperature:	-25°C to +55°C
Relative humidity:	< 95%

Architect Specifications

The speaker shall be a twin cone of 200mm diameter and be fitted with a 100V transformer with power taps of 15W, 10W, 5W, 2W and 1.25W. It shall have a SPL of 91dB and frequency response of 55Hz to 15kHz. It shall be fitted with a 4 way wire protect terminal block for cable connection and 22uf bipolar capacitor for line monitoring. The speaker shall be attached to a white aluminium grill with ABS surround & flip-lock mounting mechanism. The speaker & grill combination shall be a Redback model PA2126.