

# Rhinotracks-ST5 User Guide



## 1 Product Overview

The Rhinotracks-ST5 is the latest vehicle tracker supporting the 4G network. In addition to real-time location tracking, the Rhinotracks-ST5 can connect to multiple accessories and has a CAN interface. The Rhinotracks-ST5 features excellent and stable work performance. It is used for vehicle tracking and fleet management.

## 2 Product Function and Specifications

### 2.1 Product Function

#### 2.1.1 Location Tracking

- GPS + GSM dual-module tracking
- Real-time location query
- Track by time interval
- Track by distance
- Cornering report
- Track on a mobile phone

#### 2.1.2 Other Functions

- SMS/GPRS (UDP) communication (Rhinotracks protocol)
- Built-in 8 MB chip for recording driving routes (storing 8,192 GPRS caches, 256 SMS caches, and 131,072 GPS logs)
- Mileage report
- Low power alert for internal battery
- Built-in 3D acceleration sensor
- Support for Over-the-Air (OTA)

### 3.1 Specifications

Item	Specifications
Dimension	106 mm x 24.5 mm x 70 mm
Weight	190g
Input voltage	DC 11.4 V to 36 V/1.5 A
Standby battery	400 mAh/3.7 V
Power consumption	11 mA sleep mode current
Operating	-20°C to 55°C
Humidity	5% to 95%
Working hour	45 hours in power saving mode and 4 hours in normal mode
LED Indicator	Green indicator showing the GSM signal Blue indicator showing the GPS signal
Button/Switch	1 power button

## Rhinotracks ST-5 User Guide

Memory	8 MB
Sensor	3-axies accelerometer (used to wake the device up by vibration and detect towing)
Frequency band	2G GSM:B2(1900)/B3(1800)/B5(850)/B8(900) 3G WCDMA:B1(2100)/B2(1900)/B5(850)/B8(900) 4G FDD: B1(2100)/B2(1900)/B3(1800)/B4(2300)/B5(850) /B7(2600)/B8(900)/B28(700) LTE TDD:B40
GPS Sensitivity	-163 dB
Positioning Accuracy	2.5m
I/O port	Ignition Input

### 3 Rhinotracks ST5 and Accessories

ST5 and standard accessories:



ST5 with a built-in battery

GPS antenna

4G antenna

### 4 Appearance

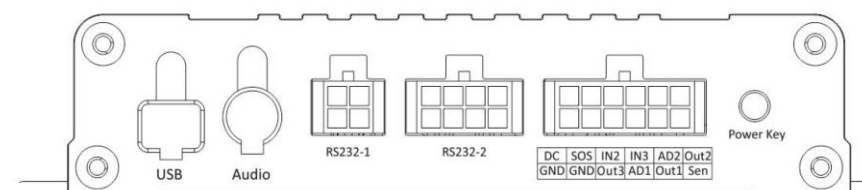
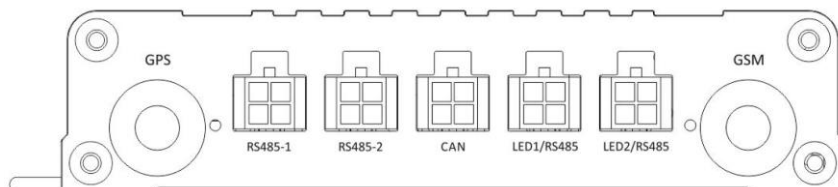
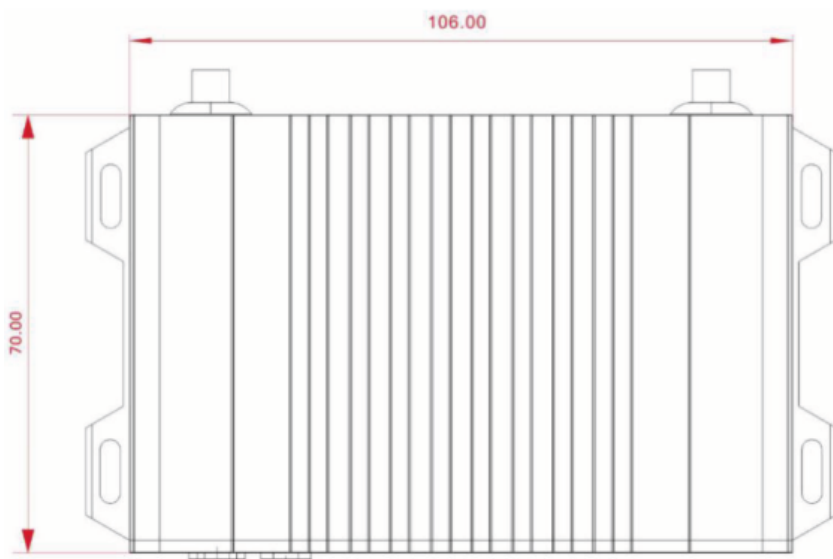

## 5 First Use

### 5.1 Indicator

Press and hold down the power button for 3s to 5s to start the ST5.

GPS Indicator (Blue)	
Blink (every 0.1s)	The ST5 is being initialized or the battery power is low.
Blink (0.1s on and 2.9s off)	A GPS signal is received.
Blink (1s on and 2s off)	No GPS signal is received.
4G Indicator (Green)	
Steady on	Strong 4G connection
Blink (every 0.1s)	The ST5 is being initialized.
Blink (0.1s on and 2.9s off)	A base station signal is received.
Blink (1s on and 2s off)	No base station signal is received.

## 6 Installing the ST5

### 6.1 Installing an I/O Cable

The I/O cable is a 12-pin connector which we are only using power and ignition input.

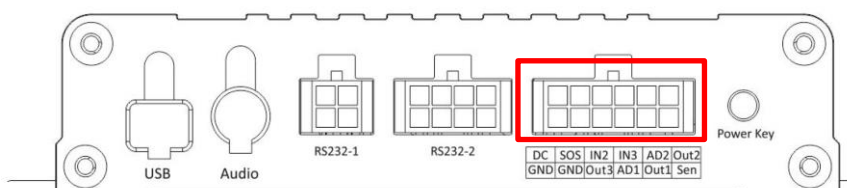

1 Power (+)	3 Not Used	5 Not Used	7 Not Used	9 Not Used	11 Not Used
2 GND (-)	4 Not Used	6 Not Used	8 Not Used	10 Not Used	12 Not Used

Pin Number	Color	Description
1 (Power +)	Red	Positive electrode of the power input, connected to the positive electrode of the vehicle storage battery. Input voltage: 11.4 V to 36 V. 12 V recommended.
2 (GND)	Black	Ground wire, connected to the negative electrode of the vehicle storage battery or to the negative terminal.
3 (Input 1)	White	Digital input 1, negative trigger (SOS button by default)
4 (GND)	Black	Ground wire, connected to input 1 (SOS button)

## Rhinotracks ST-5 User Guide

5 (Input 2)	White & Brown	Digital input 2 (negative trigger) Connect to a door trigger signal cable to detect vehicle door status. (Most Chinese, Korean, and Japanese cars are negative edge-triggered). The port can be set to positive trigger, AD input 3 (0–30 V), or output 5.
6 (Output 3)	Yellow & Red	Output 3 Valid: low level (0 V) Invalid: open collector Maximum voltage for output open collector (invalid): 40 V Maximum current for output low voltage (valid): 500 mA Connect to an external relay to remotely cut off the vehicle fuel cable or engine power supply. The port can be set to positive or negative input 6.
7 (Input 3)	White & Red	Digital input 3 (positive trigger) Connect to the vehicle ACC cable by default to detect the vehicle ACC status. The port can be set to negative trigger, AD input 6 (0–30 V), output 6.
8 (AD Input 1)	Blue	Analog input 1 with 12-bit resolution and valid voltage 0–30 V Connect to an external sensor, such as the fuel level sensor. The port can be set to positive or negative input 4 or output 7.
9 (Fuel sensor input)	Blue & Brown	Analog input 2 with 12-bit resolution and valid voltage 0–30 V There is a white plug on the AD cable, and the cable is connected to the A53 fuel level sensor by default. The port can be set to positive or negative input 5 or output 8.
10 (Output 1)	Yellow	Output 1 Valid: low level (0 V) Invalid: open collector Maximum voltage for output open collector (invalid): 40 V Maximum current for output low voltage (valid): 400 mA Connect to an external relay to remotely cut off the vehicle fuel cable or engine power supply. The port can be set to positive or negative input 7.
11 (Output 2)	Yellow & Brown	Output 2 Valid: low level (0 V) Invalid: open collector Maximum voltage for output open collector (invalid): 40 V Maximum current for output low voltage (valid): 400 mA Connect to a buzzer. The port can be set to positive or negative input 8.
12 (1-wire, Digital temperature sensor or iButton input port)	Green	TTL3.3V level Connect to the A52 digital temperature sensor or iButton by default by using the A61 sensor box. The port can be set to negative input 9 or output 4. Note: The DC or AC voltage that is greater than 3.3 V is not allowed. Otherwise, the device may be damaged.

**Power Cable/Ground Wire (PIN1, PIN2)**

Connect the power cable (red) and ground wire (black) to the positive and negative electrodes of the vehicle battery respectively.

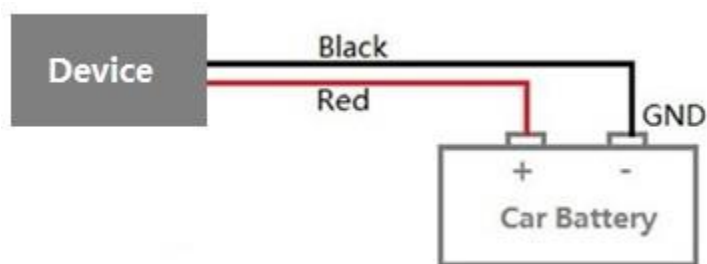

**Power (PIN1, PIN2) and ACC wiring (PIN7)**

Alternatively, you may wire the power +12V (Red) to the barrel of the key switch provided you are careful to not damage existing wiring or leave exposed wire that could cause a short circuit.

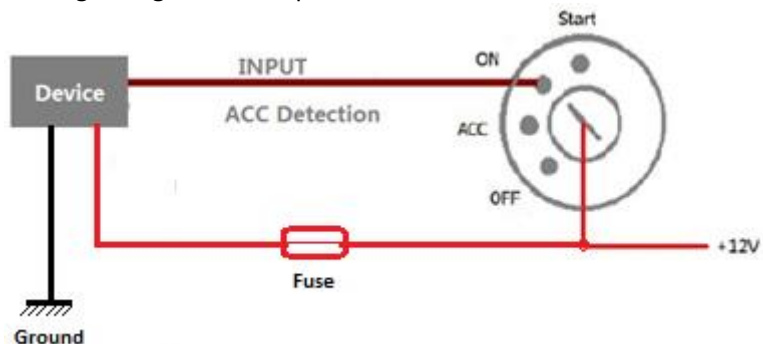

Note: If input 3 is connected to ACC and the engine is started, ON-OFF-ON conversion occurs. If input 3 is connected to Start and the engine is started, OFF-ON-OFF conversion occurs. If the device is installed correctly and the engine is started, OFF-ON conversion occurs.

**6.2 Installing GPS and 4G Antennas**

Connect the 4G antenna to the SMA connector which is labeled "GSM". The 4G antenna is non-directional, so you can hide it in any place of a vehicle.

Connect the GPS antenna to the connector which is labeled "GPS". It is recommended that the antenna is facing up to the sky and the antenna side with words is downwards. Secure the antenna with double sided tape.

Note: Do not install the GPS antenna in any position covered by metal.

**6.3 Mounting the ST5**

Tighten the four screws shown in the following figure.



If you have any questions, do not hesitate to email us at [support@rhinoco.com.au](mailto:support@rhinoco.com.au)