

PRODUCT DATA AND APPLICATION SHEET

Product Name Axial In-Line Fan

Product Code IF100, IF125, IF150

Description These powerful inline mixed flow fans have been designed to produce higher levels of extraction with low relative noise levels.

Features

- Standard with 240V 3 pin plug;
- White finish;
- Easy installation
- Protection Rating IP44.

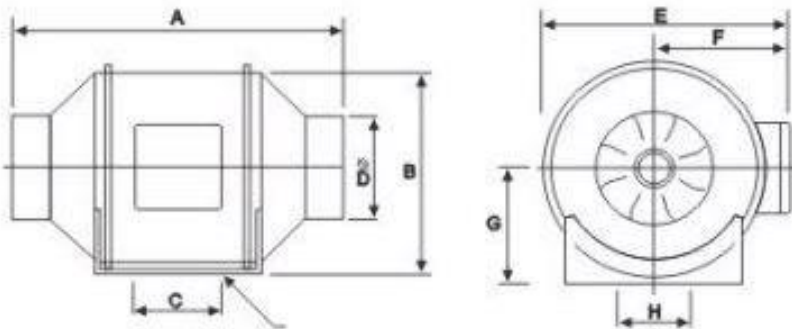

Installation Dimensions (mm)

Product Code	A	B	C	D	D	F	G	H
	mm	mm	mm	mm	mm	mm	mm	mm
IF100	300	195	80	96	202	115	100	60
IF125	255	195	80	122	202	115	100	60
IF150	315	208	80	148	226	127	112	60

Technical Parameter

Product Code	Rating voltage	Rating Frequency	Rated Speed	Airflow	Air Pressure	Power	Noise
	[V~]	[Hz]	[RPM]	[m³/h]	[Pa]	[W]	[dB]
IF100 (4")	220-240	50/60	2350	200	130	22.6	52.5
	220-240	50/60	1950	160	108	19.2	47
IF125 (5")	220-240	50/60	2350	310	138	26.9	54
	220-240	50/60	1900	230	93.6	21.6	46.5
IF150 (6")	220-240	50/60	2200	490	236	44.1	60
	220-240	50/60	1850	380	177	40.2	53