

Pairing Bluetooth

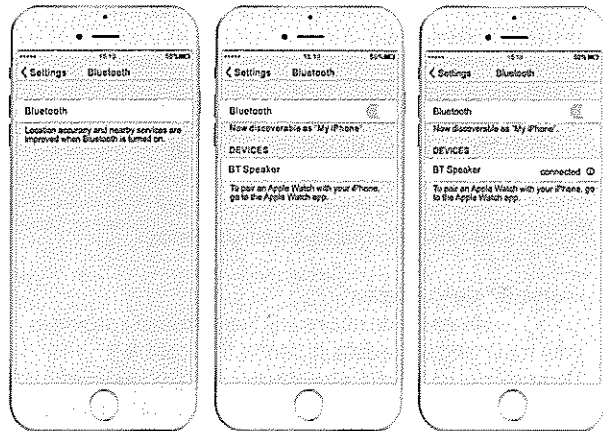

- 1. In the Settings menu of your device, enable Bluetooth.
- 2. Turn on Bluetooth in device and pair with Device: 'Ceiling Audio System', PIN: '9' '9' '8' '9'
- 3. The speaker is now connected and ready to play music

Preparation

Some of the tools and equipment you'll need to install your Ceiling Audio System are listed below. A ladder and a friend to assist will further simplify the task. A template for the cut-out has been included with each set.



Installation

Step 1 - Mark ceiling:
Locate a suitable place to fit Master & Slave, free from battens rafters and other obstructions. A Stud Finder may assist. Perforate the cardboard Mounting Hole Template, tape in place and mark the ceiling.

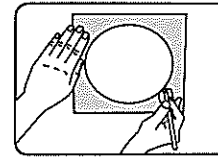

Step 2 - Cut holes:
Use a 5 or 6mm drill to make a pilot hole at a point in each line. Then cut along the line by hand, with a small plaster cutting saw. Pull the speaker and power cables through.

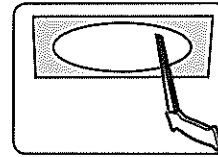

Step 3 - Connect Master:
Attach Slave speaker wires to push terminals, and power supply to Master.

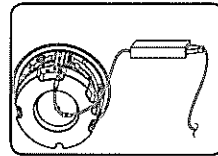

Step 4 - Fit Master:
Place in hole, taking care not to touch rubber surround or cone. With a no. 2 star screwdriver, a) loosen mounting locks (anti-clockwise), b) rotate into position (clockwise) and c) tighten all 4 locks (clockwise). Fit magnetic grille.

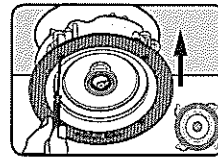

Step 5 - Connect Slave:
to speaker wire from Master. Ensure + is connected to +, to retain phasing.

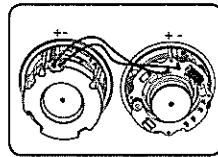

Step 6 - Fit Slave:
Place in hole, taking care not to touch rubber surround or cone. Loosen locks, rotate into position and tighten the 4 locks. Fit grille.

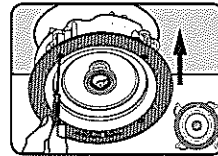

Step 7 - Power up:
Connect, test & enjoy.

healing

BLUETOOTH CEILING AUDIO SYSTEM

healing acoustic HSB826

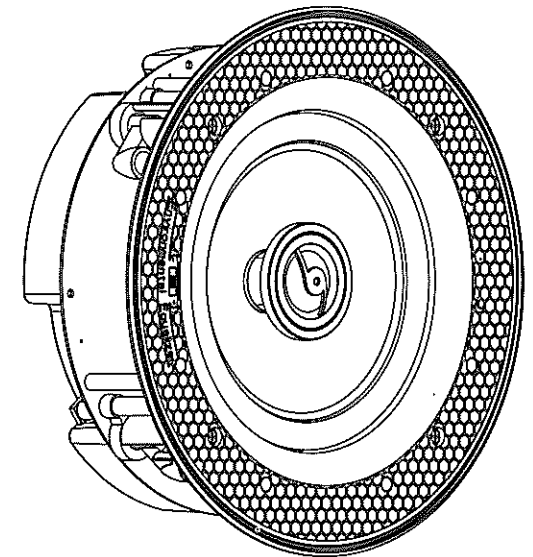

Packing List

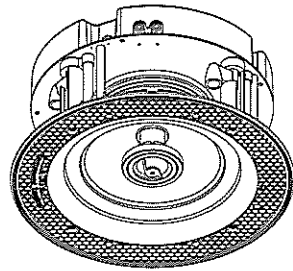

Master (active) x 1
Slave (passive) x 1

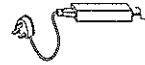

power adapter



user manual

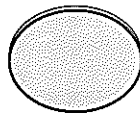

speaker grilles x 2

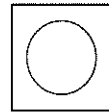

cutout template

Specifications

Frequency Response: 60Hz - 20kHz

Amplification Power RMS : 60W (30W Master/30W Slave)

Loudspeaker Impedance : 8 Ohms

Sensitivity (1W/1m): 90dB

Amplifier Class : D (Digital)

Bluetooth : V4.1

Range: <10m (33ft)

ID Device Name:

Power Input: DC 24V @2.5A

Introduction

Your Bluetooth Ceiling Audio System accepts input from the Bluetooth device of your choice or RCA line input for direct connection via a suitable cable.

Output are the Master & Slave integrated amplified loudspeakers.

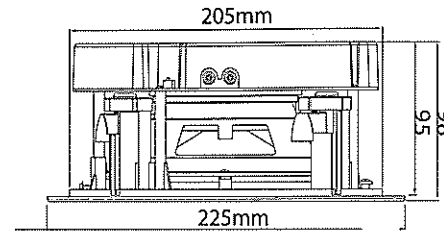

Note: Master speaker requires cavity depth of 98mm (3.9")

① Connection Reset Button

② LED Status Indicator

③ Pivoting Tweeter

④ Magnets for Grille x 8

⑤ Environmental Equalizer
(+/-3db)

⑥ Stereo / Mono Selector

⑦ RCA Inputs Left & Right ch

⑧ Volume Limit 50% / 100%

⑨ Built-in Amplifier
& Bluetooth Driver

⑩ Slave Speaker Output
Right Channel, + Red - Black

⑪ Power Input DC 24V 2.5A

⑫ Mounting Locks x 4

⑬ 6.5" (165mm)
Kevlar Woven Cone

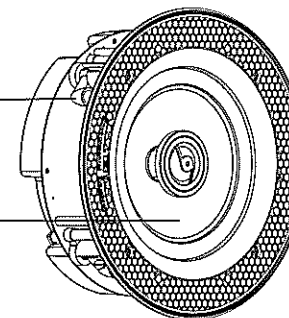
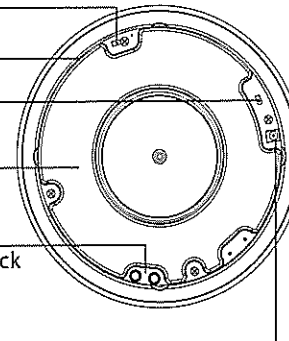
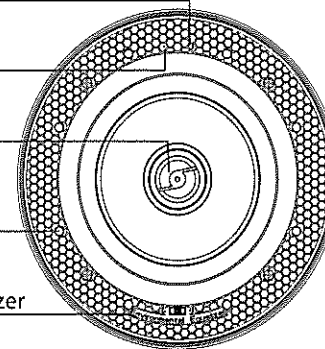

1. Connection Reset button

If system will not operate, press and hold the RESET button for around 5 seconds to reset. Don't interrupt Power whilst resetting or device may suffer permanent damage!

2. LED Status Indications

Blue flashing - Bluetooth pairing mode
Blue steady - Bluetooth connected
Green steady - AUX RCA Input connected
Red flashing slowly - Standby mode
Red flashing quickly - Amplifier error

6. Stereo / Mono selector

Stereo mode retains any Stereo sound imaging in your music and is the default. Mono, a mix of L & R channels can be helpful when Master or Slave operate in areas away from each other. Change slowly and carefully.

7. RCA Inputs

Connect directly to the device of your choice, via a suitable RCA input cable. RCA Left & Right channel inputs select automatically when Bluetooth is inactive for more than 5 seconds. This could be useful for connecting the audio from a Television or any line level audio output. Bluetooth and RCA inputs are not active at the same time. To protect the ears of those nearby, ensure your device's audio level is minimised when connecting.

8. Volume Limit

When '50%' selected system sensitivity is reduced, use as a background music system more practical.

9. Bluetooth Pairing

Apply power to the Master of your Ceiling Audio System. Flashing BLUE LED indicates the device is ready to pair. Switch your device's Bluetooth function ON and select 'Ceiling Audio System' and enter PIN '9' '9' '8' '9'. The BLUE LED will stop flashing and the speakers will play a confirmation tone when pairing is complete. Should your device fail to pair, remove and re-insert the power cable or press the Reset button on the Master as described in point 1. to re-start the pairing process.

TIP: The Amplifiers are protected against over and under voltage, short circuit and overheating. A failure in any of these areas will cause the System to shut down automatically. It will re-start once the problem has been resolved.